

# **APPENDIX G**

# **ENGINEERING SERVICES REPORT**



Structural



Civil



Flood

# Engineering Services Report

## St George Community Housing Limited C/- Colab Projects



41 & 49 Plaza Place

Carseldine

Job Reference Number – 10898

Date: 21 August 2024

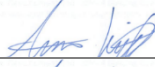
## Document Status

| Rev No | Author   | Reviewer  | Approved for Issue |  |          |        |
|--------|----------|-----------|--------------------|--|----------|--------|
|        |          |           | Name               | Signature  | Date     | RPEQ # |
| 01     | C. Omlid | A. Knight | A. Knight          |  | 19.07.24 |        |
| 02     | C. Omlid | A. Knight | A. Knight          |  | 16.08.24 | 28220  |
| 03     | C. Omlid | A. Knight | A. Knight          |  | 24.08.24 | 28220  |

## Distribution

| Rev No | Date     | Issue        | Issued To                 | Format  |
|--------|----------|--------------|---------------------------|---------|
| 01     | 19.07.24 | Draft        | Buildcorp, Colab Projects | PDF / E |
| 02     | 16.08.24 | For Approval | Buildcorp, Colab Projects | PDF / E |
| 02     | 24.08.24 | For Approval | Buildcorp, Colab Projects | PDF / E |

## TABLE OF CONTENTS

|      |   |    |
|------|---|----|
| 1    | Introduction .....                          | 5  |
| 1.1. | Purpose and Scope .....                     | 5  |
| 1.2. | Report Limitations .....                    | 6  |
| 2    | Site Characteristics .....                  | 7  |
| 2.1. | Location .....                              | 7  |
| 2.2. | Topography .....                            | 8  |
| 2.3. | Existing Services .....                     | 8  |
| 3    | Proposed Development .....                  | 9  |
| 4    | Flooding .....                              | 10 |
| 5    | Filling and Excavation .....                | 12 |
| 5.1. | Earthworks .....                            | 12 |
| 5.2. | Erosion and Sediment Control Measures ..... | 13 |
| 5.3. | Monitoring and Maintenance .....            | 15 |
| 6    | Stormwater Management .....                 | 16 |
| 6.1. | Objectives .....                            | 16 |
| 6.2. | Overall Stormwater Management .....         | 16 |
| 6.3. | Lawful Point of Discharge .....             | 16 |
| 6.4. | Stormwater Quantity Management .....        | 16 |
| 6.5. | Stormwater Quality Management .....         | 20 |
| 7    | Services, Works, and Infrastructure .....   | 22 |
| 7.1. | Policies .....                              | 22 |
| 7.2. | Sewerage Reticulation .....                 | 22 |
| 7.3. | Water Reticulation .....                    | 22 |
| 7.4. | Electricity, Communications and Gas .....   | 23 |
| 8    | Conclusions and Recommendations.....        | 24 |
| 9    | References .....                            | 25 |

## APPENDICES

APPENDIX A – ARCHITECTURAL PLANS

APPENDIX B – SURVEY PLAN

APPENDIX C – CIVIL WORKS DRAWINGS

APPENDIX D – ESTATE STORMWATER DOCUMENTATION

APPENDIX E – EROSION HAZARD ASSESSMENT

APPENDIX F – BRISBANE CITY COUNCIL CODES

## 1 Introduction

### 1.1. Purpose and Scope

Inertia Engineering has been commissioned by St George Community Housing Limited C/- Colab Projects to prepare an Engineering Services Report for the proposed development at 41 & 49 Plaza Place, Carseldine (the subject site). This report will support the development application submitted for the proposed development. The site layout and elevations are shown on the architectural plans in Appendix A.

This report addresses stormwater management (quality and quantity) during the construction and operational phases of the proposed development. It also demonstrates conceptually how the development can be serviced by water, sewer, and other infrastructure such as gas, electricity, and telecommunications. Responses to relevant Brisbane City Council (BCC) codes have been prepared.

The required detailed design for the service infrastructure will be subject to the conditions (if any) attached to the Development Approval to be provided by Council and any nominated referral agencies.

This report has been prepared in accordance with the *State Planning Policy (SPP, 2017)*, *Queensland Urban Drainage Manual Fourth Edition 2016 (QUDM, 2016)* and Brisbane City Council's *City Plan (2014)*.

Throughout this report the developable area is referred to as the 'site' which is Lot 2049 & 2050 on SP311913.

## 1.2. Report Limitations

This report has been prepared by Inertia Engineering Pty Ltd for St George Community Housing Limited C/- Colab Projects and may only be used and relied on by St George Community Housing Limited C/- Colab Projects for the purpose agreed between Inertia Engineering and St George Community Housing Limited C/- Colab Projects as detailed within this report.

Inertia Engineering otherwise disclaims responsibility to any person other than St George Community Housing Limited C/- Colab Projects arising in connection with this report. Inertia Engineering also excludes implied warranties and conditions, to the extent legally permissible.

The services undertaken by Inertia Engineering in connection with preparing this report were limited to those specifically detailed in the report and are subject to the scope limitations set out in the report.

The opinions, conclusions and any recommendations in this report are based on conditions encountered and information reviewed at the date of preparation of the report. Inertia Engineering has no responsibility or obligation to update this report to account for events or changes occurring after the date that the report was prepared.

The opinions, conclusions and any recommendations in this report are based on assumptions made by Inertia Engineering described in this report. Inertia Engineering disclaims liability arising from any of the assumptions being incorrect.

Inertia Engineering has prepared this report based on information provided by St George Community Housing Limited C/- Colab Projects and others who provided information to Inertia Engineering (including Government authorities), which Inertia Engineering has not independently verified or checked beyond the agreed scope of work. Inertia Engineering does not accept liability in connection with such unverified information, including errors and omissions in the report which were caused by errors or omissions in that information.

## 2 Site Characteristics

The land contained within the site is described as follows:

|                 |                                 |
|-----------------|---------------------------------|
| Title Details:  | Lot 2049 & 2050 on SP311913     |
| Street Address: | 41 & 49 Plaza Place, Carseldine |
| Area:           | Total: 4270 m <sup>2</sup>      |

Refer to Appendix B for Survey Plan / BYDA information.

### 2.1. Location

The subject site is located in Carseldine, approximately 13km north from Brisbane CBD. The site occupies a total of 4270m<sup>2</sup> and lies within Emerging Community zone. The site is bound by car parking to the south, vegetation to the north and west, and Plaza Place to the east.



Figure 2-1 - Location Plan



## 2.2. Topography

The site sits generally between 14.5m and 15m AHD, with a small portion in the middle of the site at 16m AHD.

## 2.3. Existing Services

Detailed survey by Land Partners, 'Before You Dig Australia' (BYDA) data and as-constructed data covering the existing infrastructure services and utilities for the site and surrounding area has been obtained to determine any infrastructure required for the development. This existing infrastructure is outlined in the following sections.

### 2.3.1. Stormwater

Stormwater infrastructure has been constructed as part of the estate masterplan. The drainage within Plaza Place fronting the site includes two kerb inlet pits draining via a 375mm dia connection to the twin 1350mm dia stormwater pipes running along Plaza Place. The survey has not identified any stormwater infrastructure within the site.

Note that the location of the stormwater network external to the site has been determined from estate civil plans, included in Appendix D.

### 2.3.2. Sewer

There is an existing 160mm PE sewer line in Plaza Place with two 160mm sewer property connections, one for each lot.

Note that the location of the sewer network external to the site has been determined from the BCC Urban Utilities mapping service.

### 2.3.3. Water

There is a 150mm PE water main along Plaza Place. Urban Utilities mapping does not identify water property connections.

Note that the location of the water network external to the site has been determined from the BCC Urban Utilities mapping service and Stage 5 civil drawings, included in Appendix D.

### 2.3.4. Electrical/Gas/Telecommunications

There is NBN, TPG, and Energex within close proximity to the site.

Note that the location of infrastructure external to the site has been determined from BYDA data.

### 3 Proposed Development

The proposed site consists of two six-storey towers with a total of 152 units across both towers. Refer to Figure 3-1 for the proposed development layout.

Refer to Appendix A for the proposed site layout and elevations.



Figure 3-1 - Proposed Development

## 4 Flooding

The subject site is mapped as being subject to BCC creek/waterway flood planning areas 5, 4, and 3 as per Council flood overlays. This flood overlay is now out of date since the estate has been developed, which included filling within the mapped overlays. Flood modelling has been completed on the Carseldine Village development, conducted as per the DesignFlow stormwater management plan (2019). This report details a redirection of flows around the site as part of the development masterplan, and as a result the site is considered to be flood-free. Refer to Appendix D for technical memorandums and flood reports previously completed on the site.

Notwithstanding, the site is situated near an overland flow path. Under the estate civil works, a drainage channel which runs along the rear of the site which was constructed. Refer to Appendix D for the drainage channel drawings. The site's minimum levels have been set to provide flood immunity to the overland flow in this drainage channel. According to Table 8.2.11.3.L of the BCC Planning Scheme for overland flow, this sets the minimum flood levels as per Table 4-1.

*Table 4-1 - Minimum Floor Level Requirements*

| Category              | Minimum level requirement  | 2% AEP Flood level (m AHD) | Minimum Floor level (m AHD) |
|-----------------------|----------------------------|----------------------------|-----------------------------|
| Habitable floor level | 2% AEP flood level + 500mm | 15.38                      | 15.88                       |
| Car parking           | 2% AEP flood level         | 15.38                      | 15.38                       |

The floor levels requirements noted above are based upon the upstream chainage of the overland flow path. There is opportunity to adopt lower FFLs at the lower reaches of the overland flow path.

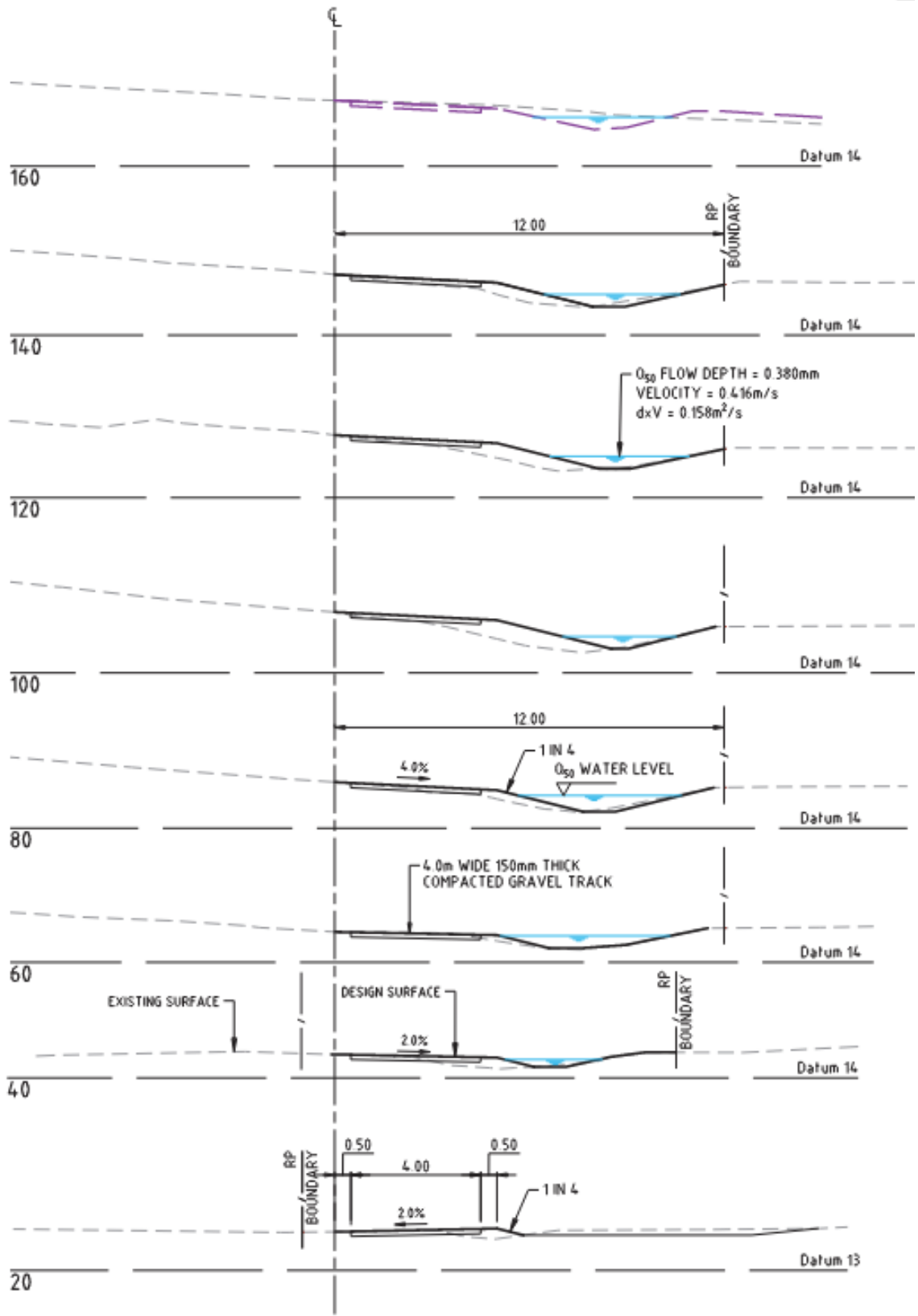

**CROSS SECTIONS - CATCH DRAIN PHASE 1 WORKS**

SCALE 1 : 100

Figure 4-1 - Drainage channel (Drawing No: 22-106-07 Rev A KN Group)

## 5 Filling and Excavation

### 5.1. Earthworks

It is proposed that after adequate pre-construction sediment and erosion control measures have been implemented, the required demolition will occur with the safe removal of any material off site. Earthworks for the proposed development will occur with batters preferred (where possible) in place of retaining walls. Any required retaining walls are proposed to be reinforced block work or as nominated by the architectural design drawings. Any proposed fill retaining walls are recommended to be offset half the height of the wall from any site boundary.

The proposed pad level for the building is RL 15.90m and will require a maximum of approximately 1.0m of fill to achieve the design levels. Refer to Appendix C which shows a schematic of the earthworks proposed for the site.

In all situations where earthworks are proposed and any ground is disturbed by construction works, sediment and erosion control measures will be implemented in accordance with the following documents:

- Relevant BCC sediment and erosion control guidelines;
- International Erosion Control Association (IECA) Sediment and Erosion Control Guidelines; and
- Australian Standards AS 3798-2007.

Given that the site is below RL 20m AHD, the proposed development is considered to be prospective land for the existence of acid sulphate soils (ASS). As such, an acid sulphate soil investigation will need to be carried out by a geotechnical/environmental engineer for the site to confirm the potential presence of acid sulphate soils. If present, an acid sulphate soils management plan will be prepared.

As a Material Change of Use application is required, any filling and excavation including retaining works is to comply with BCC's Filling and Excavation code. Responses to BCC's Filling and Excavation Code are shown in Appendix E.

## 5.2. Erosion and Sediment Control Measures

### 5.2.1. Pre-Development

Prior to construction, the following erosion and sediment control measures will be implemented to minimise disturbance and ensure water quality is maintained:

- Set out transport routes to ensure minimal vegetation disturbance;
- Construct entry/exit areas that comprise a designed gravel pad or hardwood logs in accordance with the IECA (2001); and
- Install sediment fences around the proposed bulk earthworks site (along toe of batter alignment).

### 5.2.2. Bulk Earthworks

- Earthworks areas are to be protected against wind and water erosion;
- Silt fences are to be erected around the base of the earthworks and material stockpiles;
- Stockpiles and construction material are not permitted to be stored within the road reserve; and,
- Diversion drains to be provided at upstream catchments to reduce flows onto earthworks areas.

### 5.2.3. Construction

The following measures will be undertaken to mitigate water quality impacts during the construction phase:

- Sediment fences to be erected at the base of all batters and stockpiles to prevent sediment transportation off site;
- Grass filter strips to be placed along all road verges;
- Re-vegetation of all disturbed areas within two weeks of completion;
- All sediment control structures to be maintained in an effective manner and inspected after each storm event. No structure is to accumulate sediment above 40% of its capacity;
- Dust producing areas to be swept to remove silt/dust and wetting of roads is only permitted where sweeping has failed; and
- At least one bin or litter trap is to be provided for waste material.

### 5.2.4. Post-Development-Maintenance Period

Sediment fences are to remain in place until the landscaping has established.

### 5.2.5. Performance Objectives and Indicators

The State Planning Policy July 2017 states the desired stormwater outcomes shown in Table 1. stormwater runoff during the construction phase must be in accordance within the concentration ranges shown in Table 5-1 below.

Table 5-1 - Construction Phase Objectives

| Issue  | Desired outcomes  |
|--|---|
| Drainage control                             | <ol style="list-style-type: none"> <li>1. Manage stormwater flows around or through areas of exposed soil to avoid contamination.</li> <li>2. Manage sheet flows in order to avoid or minimise the generation of rill or gully erosion.</li> <li>3. Provide stable concentrated flow paths to achieve the construction phase stormwater management design objectives for temporary drainage works.</li> <li>4. Provide emergency spillways for sediment basins to achieve the construction phase stormwater management design objectives for emergency spillways on temporary sediment basins.</li> </ol>   |
| Erosion control                              | <ol style="list-style-type: none"> <li>1. Stage clearing and construction works to minimise the area of exposed soil at any one time.</li> <li>2. Effectively cover or stabilise exposed soils prior to predicted rainfall.</li> <li>3. Prior to completion of works for the development, and prior to removal of sediment controls, all site surfaces must be effectively stabilised using methods which will achieve effective short-term stabilisation.</li> </ol>   |
| Sediment control                             | <ol style="list-style-type: none"> <li>1. Direct runoff from exposed site soils to sediment controls that are appropriate to the extent of disturbance and level of erosion risk.</li> <li>2. All exposed areas greater than 2500 metres<sup>2</sup> must be provided with sediment controls which are designed, implemented and maintained to a standard which would achieve at least 80% of the average annual runoff volume of the contributing catchment treated (i.e. 80% hydrological effectiveness) to 50mg/L Total Suspended Solids (TSS) or less, and pH in the range (6.5–8.5).</li> </ol>  |
| Litter, hydrocarbons and other contaminants  | <ol style="list-style-type: none"> <li>1. Remove gross pollutants and litter.</li> <li>2. Avoid the release of oil or visible sheen to released waters.</li> <li>3. Dispose of waste containing contaminants at authorised facilities.</li> </ol>   |
| Waterway stability and flood flow management | <ol style="list-style-type: none"> <li>1. Where measures are required to meet post-construction waterway stability objectives (specified in table B), these are either installed prior to land disturbance and are integrated with erosion and sediment controls, or equivalent alternative measures are implemented during construction.</li> <li>2. Earthworks and the implementation of erosion and sediment controls are undertaken in ways which ensure flooding characteristics (including stormwater quantity characteristics) external to the development site are not worsened during construction for all events up to and including the 1 in 100 year ARI (1% AEP).</li> </ol> |

### 5.3. Monitoring and Maintenance

The following monitoring and maintenance procedures are to be undertaken by the site supervisor during all phases of the development:

- Restrict all work activities to designated construction areas;
- Earthworks and site cleaning are undertaken in accordance with the Erosion and Sediment Control plans;
- Inspections of Stormwater and Sediment and Erosion Controls are to be conducted at the end of each construction day and after each rainfall event (>25mm); and
- Any failure to the stormwater system shall be immediately rectified to prevent uncontrolled discharge from the site.



## 6 Stormwater Management

### 6.1. Objectives

The stormwater management objectives have been set in accordance with QUDM (2016) and BCC City Plan (2014), including but not limited to:

- The proposed development shall ensure that all stormwater drainage is directed to a lawful point of discharge in accordance with QUDM Section 3.9 (2016);
- No adverse impact on adjoining or downstream properties; and
- Water quality treatment to achieve the SPP water quality objectives.

### 6.2. Overall Stormwater Management

The overall stormwater management strategy consists of the following:

- Estate stormwater is treated by biobasins as part of the larger development. Stage 3 (the development site) is to be treated by bioretention basin B2 to the south, discharging to Cabbage Tree Creek, meeting the state water quality targets for the site.
- Stormwater runoff for a fully developed site was considered as part of the estate flood modelling. Modelling shows improved flooding conditions due to the site draining directly to the creek and other flood mitigation measures (such as flood barriers and the use of the sports field as flood storage). Therefore, no stormwater detention is proposed.
- Minor flows to be taken by underground pipes, and overland flows for major events as per Calibre Group drawings (refer to Appendix D).

Refer to “Carseldine Urban Village Updated Stormwater Management Plan” (2019) by DesignFlow included in Appendix D for further details.

### 6.3. Lawful Point of Discharge

The nominated lawful point of discharge for the site is the two existing kerb inlet pits within Plaza Place. Refer to Appendix D for the stormwater infrastructure drawings.

### 6.4. Stormwater Quantity Management

#### 6.4.1. Stormwater Quantity Calculations

The Rational Method was used to estimate the site flow for both the existing and developed site conditions.

#### Existing Conditions

The subject site consists of two catchments.

- EX1 (0% impervious, 2250m<sup>2</sup>) – Ground discharging to the drain along the rear of the site as sheet flow

- EX2 (0% impervious, 1720m<sup>2</sup>) – Ground discharging to Plaza Place as sheet flow

The total fraction impervious for the existing catchment is 0%. Note that the existing catchment includes the site only and does not include any external areas.

Table 6-1 – Existing Site Flows (EX1 to rear of site)

| Parameters              | Units | Design Storm Event (yr ARI) |       |        |        |        |        |        |
|-------------------------|-------|-----------------------------|-------|--------|--------|--------|--------|--------|
|                         |       | 1                           | 2     | 5      | 10     | 20     | 50     | 100    |
| Catchment Area          | ha    | 0.255                       |       |        |        |        |        |        |
| Time of Concentration   | min   | 19.0                        |       |        |        |        |        |        |
| Runoff Coefficient (Cy) |       | 0.53                        | 0.56  | 0.63   | 0.66   | 0.69   | 0.76   | 0.79   |
| Rainfall Intensity (ly) | mm/hr | 71.24                       | 80.41 | 108.82 | 127.81 | 146.15 | 170.05 | 188.08 |
| Peak Flow               | L/s   | 27                          | 32    | 48     | 60     | 72     | 91     | 106    |

Table 6-2 – Existing Site Flows (EX2 to Plaza Place)

| Parameters              | Units | Design Storm Event (yr ARI) |       |        |        |        |        |        |
|-------------------------|-------|-----------------------------|-------|--------|--------|--------|--------|--------|
|                         |       | 1                           | 2     | 5      | 10     | 20     | 50     | 100    |
| Catchment Area          | ha    | 0.172                       |       |        |        |        |        |        |
| Time of Concentration   | min   | 20.0                        |       |        |        |        |        |        |
| Runoff Coefficient (Cy) |       | 0.53                        | 0.56  | 0.63   | 0.66   | 0.69   | 0.76   | 0.79   |
| Rainfall Intensity (ly) | mm/hr | 69.42                       | 78.35 | 106.05 | 124.57 | 142.47 | 165.81 | 183.44 |
| Peak Flow               | L/s   | 18                          | 21    | 32     | 39     | 47     | 60     | 69     |

### Developed Conditions

Under developed conditions, there are two internal catchments:

- C1 (90% impervious, 2106m<sup>2</sup>) – Northern portion of the site discharging to Plaza PI stormwater infrastructure
- C2 (90% impervious, 2164m<sup>2</sup>) – Southern portion of the site discharging to Plaza PI stormwater infrastructure

The total fraction impervious of the developed catchment is 90%. Note that the developed catchment includes the site only and does not include any external areas.

Table 6-3 – Developed Site Flows (C1)

| Parameters              | Units | Design Storm Event (yr ARI) |        |        |        |        |        |        |
|-------------------------|-------|-----------------------------|--------|--------|--------|--------|--------|--------|
|                         |       | 1                           | 2      | 5      | 10     | 20     | 50     | 100    |
| Catchment Area          | ha    | 0.211                       |        |        |        |        |        |        |
| Time of Concentration   | min   | 6.0                         |        |        |        |        |        |        |
| Runoff Coefficient (Cy) |       | 0.68                        | 0.73   | 0.81   | 0.86   | 0.90   | 0.98   | 1.00   |
| Rainfall Intensity (ly) | mm/hr | 109.75                      | 123.89 | 167.96 | 197.63 | 226.47 | 264.38 | 293.22 |
| Peak Flow               | L/s   | 44                          | 53     | 80     | 99     | 119    | 152    | 172    |

Table 6-4 – Developed Site Flows (C2)

| Parameters              | Units | Design Storm Event (yr ARI) |        |        |        |        |        |        |
|-------------------------|-------|-----------------------------|--------|--------|--------|--------|--------|--------|
|                         |       | 1                           | 2      | 5      | 10     | 20     | 50     | 100    |
| Catchment Area          | ha    | 0.216                       |        |        |        |        |        |        |
| Time of Concentration   | min   | 6.0                         |        |        |        |        |        |        |
| Runoff Coefficient (Cy) |       | 0.68                        | 0.73   | 0.81   | 0.86   | 0.90   | 0.98   | 1.00   |
| Rainfall Intensity (ly) | mm/hr | 109.75                      | 123.89 | 167.96 | 197.63 | 226.47 | 264.38 | 293.22 |
| Peak Flow               | L/s   | 45                          | 54     | 82     | 102    | 122    | 156    | 176    |

### External Upstream Catchments

There are no upstream catchments due to the installation of the concrete drain to the rear of the site, which diverts any upstream flows from the existing vegetation around the site.

#### 6.4.2. Stormwater Detention Requirements

In accordance with the BCC City Plan Schedule 6 - Section 7.5.2 (2014), stormwater detention may be required under three specific conditions:

- When a development is likely to increase run-off to such an extent that the downstream drainage (both piped and overland) cannot cater for the additional capacity or adverse impacts are created;
- Where there is no practical way to increase the downstream system capacity; and
- If the increase in flows from the development would cause adverse flooding impacts to adjacent or downstream properties.

The BCC City Plan (2014) then continues to state that stormwater detention requirements may be waived where:

- The development will not cause adverse impacts or actionable nuisance to surrounding properties;
- The site discharges directly into the lower catchments of creeks or major drains where it would generally be undesirable to have detention where it may allow peak flows from the site to coincide with the wider catchment flood peak;
- The proposal is for residential development where stormwater is disposed to Council’s kerb and channel or piped stormwater system and major flows from the site would drain to Councils road reserve.

Flood modelling for the “Carseldine Urban Village Updated Stormwater Management Plan” (2019) by DesignFlow (refer to Appendix D) has accounted for a 90% impervious area developed area for the catchment in which 41 & 49 Plaza Street sits. As the proposed developed case for the site is 90% impervious, this sits within the assumptions made within the 2019 stormwater management report. As per Section 5.3.3, “Flood impact maps demonstrate no significant adverse impacts occurring

*external to the site as a result of the development*". Despite the overall loss of flood storage across the development of Carseldine Village, flood modelling indicates no adverse impacts due to the site's relatively minor impact compared to the creek catchment and other flood mitigation devices such as using the sports field as flood storage.

Therefore, as the site discharges directly into the lower catchments of Cabbage Creek and flood modelling has indicated no adverse impacts due to development, no stormwater detention is proposed.

#### 6.4.3. Stormwater Infrastructure

Stormwater infrastructure was constructed as part of the larger Carseldine Urban Village development. Refer to Appendix D for Calibre Group stormwater drainage plans.

This stormwater infrastructure includes two connection points of 375mm dia pipes, one for each existing lot. These connect to twin 1530mm dia pipes within Plaza Place, which discharge to the biobasin to the south. These pipes have been designed for a 90% impervious developed site. According to the Calibre Group drawings, these stormwater pipes have been designed for the Q2 event. A capacity assessment has been completed as per Table 4-1 to show the existing stormwater infrastructure has sufficient capacity to convey post-developed site runoff. Refer to Calibre Group stormwater drawing *1401-RevB* in Appendix D for further details of the existing stormwater infrastructure.

*Table 6-5 - Pipe Capacity Check*

| Pipe ID       | Size (mm dia) | Slope | Capacity at Grade (L/s) | Calculated Inflow (10% AEP) |
|---------------|---------------|-------|-------------------------|-----------------------------|
| G1/AH (LPOD1) | 375           | 2.03% | 250                     | 99*                         |
| 6/AA (LPOD1)  | 2x1350        | 0.2%  | 4600                    | 2782**                      |
| G1/AG (LPOD2) | 375           | 1.39% | 207                     | 102*                        |
| 5/AA (LPOD2)  | 2x 1350       | 0.2%  | 4600                    | 2940**                      |

\*Rational method calculations from Section 6.4.1

\*\* From Calibre Group Stormwater drawings

## 6.5. Stormwater Quality Management

### 6.5.1. Introduction

The operational phase of the management plan focuses on appropriate consideration of Stormwater Quality Improvement Devices and Water Sensitive Urban Design (WSUD) principles to be incorporated into the total water cycle management of the developed site.

The State Planning Policy (2017) states for a proposed material change of use that involves a site area greater than 2,500m<sup>2</sup> and will result in an impervious area greater than 25% a Site Based Stormwater Quality Management Plan is required.

### 6.5.2. Pollutants

Pollutants typically generated during the operational phase of the development are shown below (BCC, 2015).

Table 6-6 – Pollutants typically generated during the operational phase

| Pollutant                          | Sources  |
|------------------------------------|--|
| Litter                             | Construction, construction, food waste materials |
| Sediment                           | Exposed soils and stockpiles                     |
| Oxygen demanding substances        | Organic or chemical matter                       |
| Nutrients (N & P)                  | Nitrogen, phosphorus                             |
| Pathogens / Faecal coliforms       | Sewerage   |
| Hydrocarbons                       | Fuel and oil spills                              |
| Heavy metals (with fine sediment)  | Sediment runoff                                  |
| Surfactants                        | Detergents from car washing, cleansing agents    |
| Organochlorines & organophosphates | Pesticides, herbicides                           |
| Thermal pollution                  | Heat (i.e. runoff from impervious areas)         |
| pH altering substances             | Washwaters                                       |

### 6.5.3. Water Quality Objectives

The State Planning Policy (2017) sets out the following water quality objectives for South East Queensland in order to protect downstream receiving waters:

- Total Suspended Solids (TSS)                      80% reduction
- Total Phosphorus (TP)                                60% reduction
- Total Nitrogen (TN)                                  45% reduction
- Gross Pollutant (>5mm)                         90% reduction

The percent reductions listed above are the target reductions for comparing mitigated site annual pollutant loads with unmitigated site annual pollutant loads. The proposed treatment strategy selected for the development will ensure these objectives are met for all pollutants.

**6.5.4. Proposed Treatment Strategy**

As per the “Carseldine Urban Village Updated Stormwater Management Plan” (2019) stormwater management report by DesignFlow, the site is treated as part of the development as a whole, with the site runoff being treating by bioretention basin B2 to meet the state planning policy water quality objectives, located to the south of the site. This bioretention basin discharges to Cabbage Tree Creek.

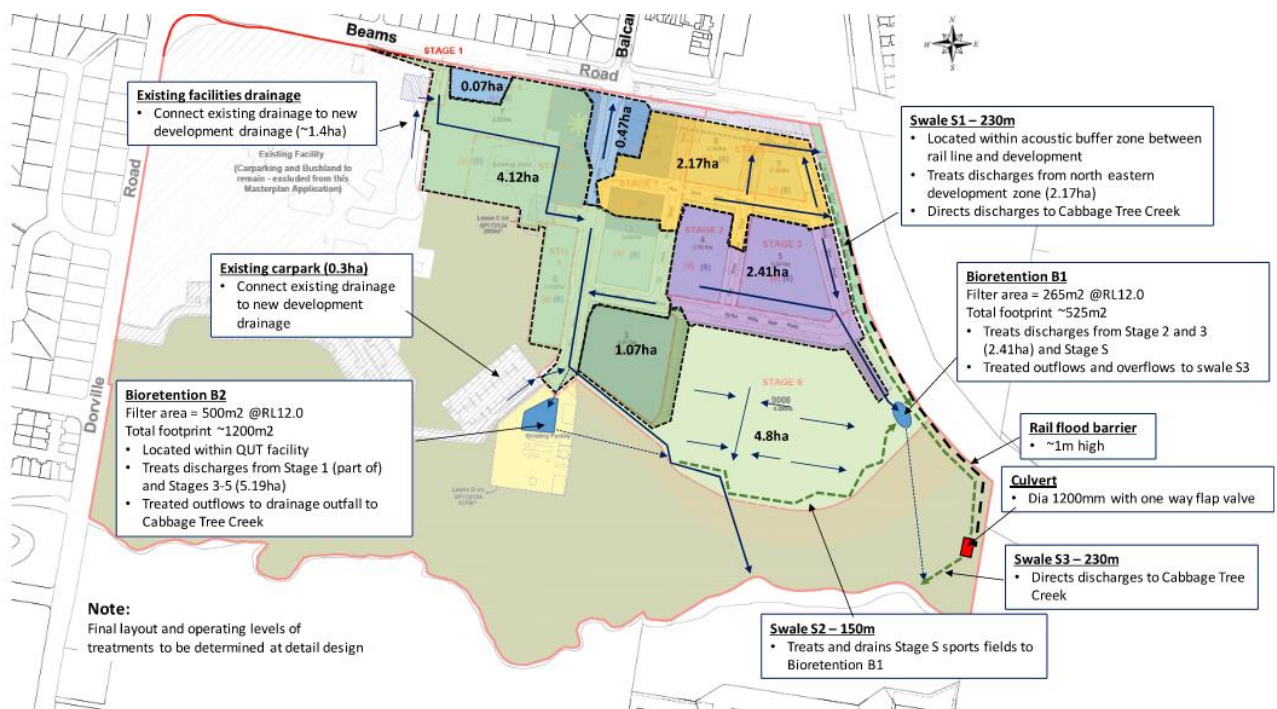

Figure 5 Stormwater Management Strategy Carseldine Urban Village

Figure 6-1 - Carseldine Urban Village Overall Stormwater Management Plan (DesignFlow 2019)

As such, no further on-site stormwater quality management is proposed for the development.

## 7 Services, Works, and Infrastructure

### 7.1. Policies

The internal sewerage and water reticulation works proposed within the development will comply with the following documents:

- AS 3500.2 Plumbing and Drainage – Sanitary plumbing and drainage; and
- AS 3500.1 Plumbing and Drainage – Water Services.

All privately owned water supply infrastructure will be designed in accordance with the relevant plumbing and drainage standards to ensure adequate connection to the UU owned water reticulation main. Any live works will comply with the following documents:

- Relevant UU development guidelines & standard drawings;
- SEQ WS&S D&C Code – Amendment to Sewerage Code of Australia; and
- Water Association of Australia (WSAA) Sewerage Code of Australia guidelines and standard drawings.

### 7.2. Sewerage Reticulation

The site is to connect to the existing 160mm dia. sewer property connections, serviced by the existing 250mm dia. PE water within Plaza Place.

A 2018 SAN placed with UU by Calibre Consulting, refer to Appendix D, for connection to the existing sewer network as well as a wastewater network report for the Carseldine Village development. The SAN shows the network had adequate capacity for the development.

Note that the suitability of this proposed connection point is subject to discussions with UU to be undertaken at the Operational Works stage.

Detailed sewer reticulation drawings will be provided as part of the future Operational Works for civil works application once the development application has been approved by Council.

Please refer Appendix C which illustrates the schematic services layout.

### 7.3. Water Reticulation

A 250mm PE water main is under construction as part of Stage 5 to the north of the site. A new property connection is to be constructed to connect to this proposed main to service the development.

A 2018 SAN placed with UU by Calibre Consulting, refer to Appendix D, for connection to the existing water network as well as a wastewater network report for the Carseldine Village development. The SAN shows the network had adequate capacity for the development.

Note that the suitability of this proposed connection point is subject to discussions with UU to be undertaken at the Operational Works stage.

Any works connections to the existing water main shall be carried out by UU at the cost of the applicant unless written permission is granted for connection to be made by a nominated contractor. The contractor shall take all precautions to minimise inconvenience to the residences serviced by the existing water infrastructure.

Detailed water reticulation drawings will be provided as part of a future Operational Works for civil works application once the development application has been approved by Council.

Please refer to Appendix C which illustrates the proposed services layout.

#### 7.4. Electricity, Communications and Gas

Electricity, gas, and telecommunication infrastructure is available in the near vicinity of the subject site. Although the capacity of these existing services has not been determined, it is anticipated that the availability of these services and the required capacity for the proposed development should not pose an issue to the completion of the project.

The developer or an electrical consultant should contact the NBN during the Operational Works phase to confirm their requirements for the development.

Please refer to Appendix C for an illustration of the proposed services layout.



## 8 Conclusions and Recommendations

This Engineering Services Report has assessed the stormwater management, earthworks, and service infrastructure for the proposed development at 41 & 49 Plaza Place, Carseldine. Earthworks, erosion, and sediment control solutions required on site can be performed using common and accepted methods. It is noted that the proposed earthworks will trigger retaining works which will have to be constructed according to BCC codes.

The stormwater management strategy has the following components:

- Site to discharge to existing stormwater infrastructure in Plaza Place. The infrastructure within Plaza Place has been designed to accommodate the developed site flows.
- Site stormwater is treated by the existing bioretention basin to the south, constructed as part of the estate works.
- Flood modelling for the entire estate considers a fully developed site and shows no adverse impacts on the downstream creek flooding, and thus no stormwater detention is proposed.

The proposed civil services strategy has the following components:

- Re-use of the existing sewer connections to infrastructure available within Plaza Place.
- Construct new property service connection to the water main to the north of the site under construction as part of Stage 5.

Service supply points for water and sewer reticulation, electricity, telecommunications and gas are located within close proximity to the proposed development and should not present any major connection issues.

This report has demonstrated that the proposed development proposal provides an acceptable solution for all engineering services and has been designed to comply with BCC's City Plan (2014).

## 9 References

AS/NZS (2003) Australian Standards/New Zealand Standards, 'Plumbing and Drainage – Part 1: Water Services', 2003

AS/NZS (2003) Australian Standards/New Zealand Standards, 'Plumbing and Drainage – Part 2: Sanitary Plumbing and Drainage', 2003

BCC (2014) Brisbane City Council, Guidelines and Standards

- Filling and Excavation Code
- Infrastructure Design Code
- Stormwater Code

Department of State Development, Infrastructure and Planning (2017), State Planning Policy

Institute of Public Works Engineering Australasia, Queensland Division (2016), Queensland Urban Drainage Manual Fourth Edition 2016 – Provisional

SEQ WS&S D&C Code (2013), 'South East Queensland Water Supply & Sewer Design & Construction Codes – Amendments to Water & Sewerage Codes of Australia, 2013

WSAA (2002) Water Services Association of Australia, 'Water Supply Code of Australia – Part 1: Planning and Design', 2002

WSAA (2002) Water Services Association of Australia, 'Sewerage Code of Australia – Part 1: Planning and Design', 2002



## Appendices



## Appendix A – Architectural Plans

DKO

# 41-49 Plaza Place Carseldine

DEVELOPMENT APPLICATION  
19/08/2024



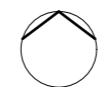
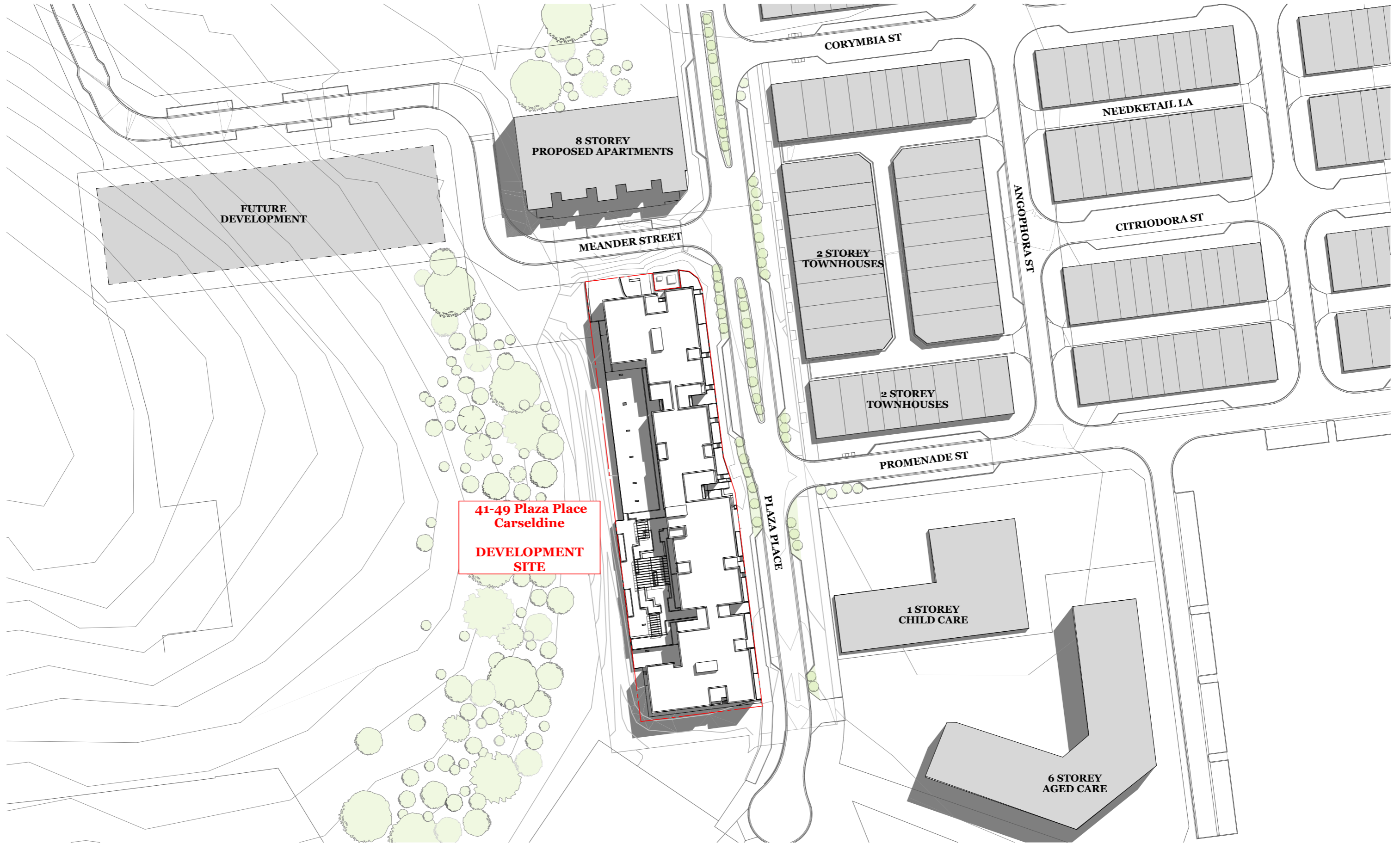

**Plans**  
Ground Floor Plan

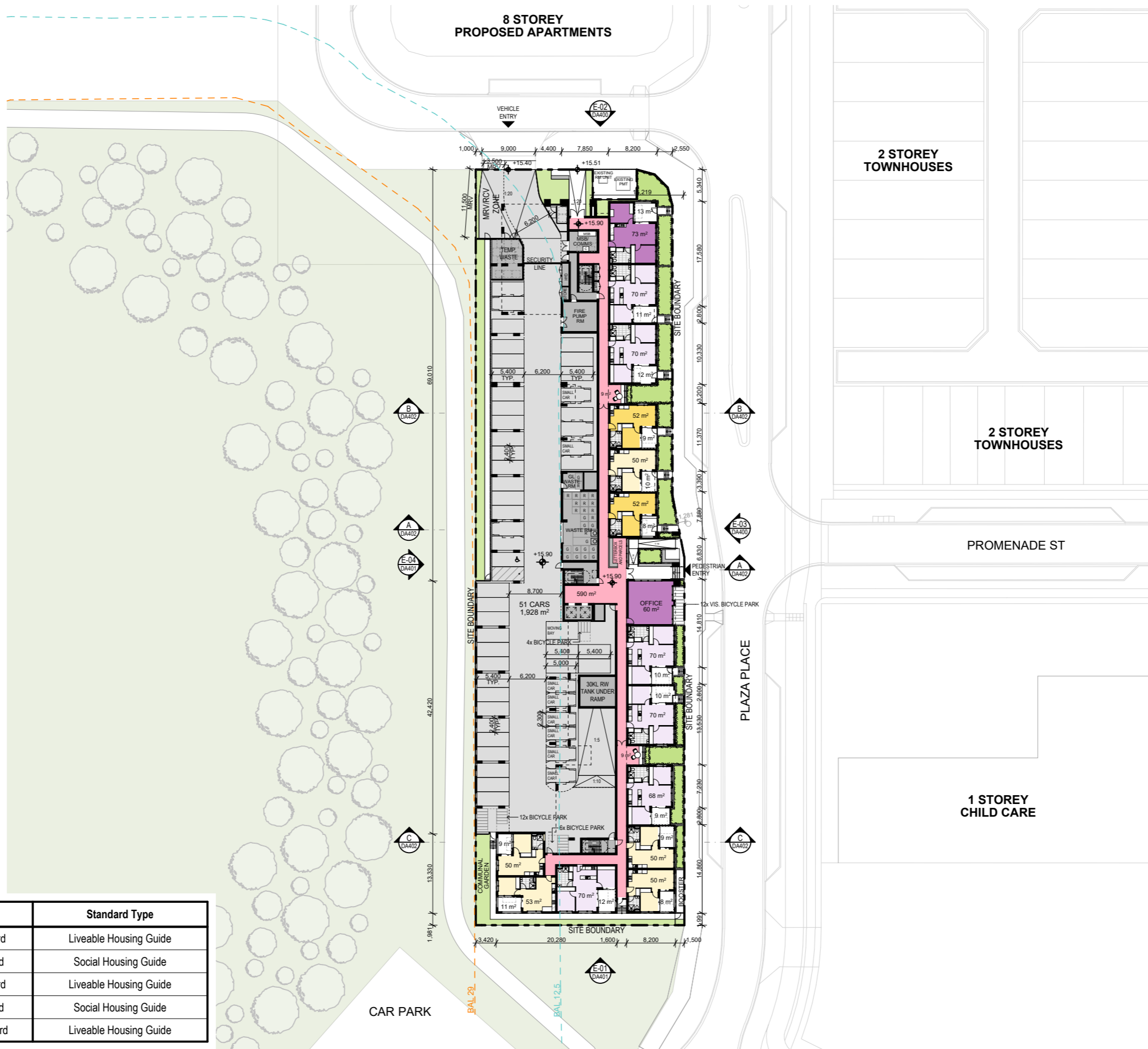

| Unit Type      | Unit Standard   | Standard Type          |
|----------------|-----------------|------------------------|
| 1 Bed 1 Bath   | Silver Standard | Liveable Housing Guide |
| 1 Bed 1 Bath   | Gold Standard   | Social Housing Guide   |
| 2 Bed 1 Bath   | Silver Standard | Liveable Housing Guide |
| 2 Bed 1 Bath   | Gold Standard   | Social Housing Guide   |
| 3 Bed 1.5 Bath | Silver Standard | Liveable Housing Guide |



DKO Architecture (QLD) Pty Ltd  
Level 3, 232 Adelaide Street  
Brisbane, QLD 4000  
ABN: 61413783636

T +61 7 3726 9588  
info@DKO.com.au  
www.DKO.com.au

© DKO Architecture (QLD) Pty Ltd  
Except as allowed under copyright act, no part of this drawing may be reproduced or otherwise dealt with without written permission of DKO Architecture.



Project Name  
Project Number  
Date  
Scale

CARSELDINE  
COMMUNITY HOUSING  
00013408  
19/08/2024  
1:700, 1:50@A3

Drawing Name  
Drawing Number  
Revision

Ground Floor Plan  
**DA302**  
**A**



# Elevations & Sections

## N & E Elevations



EF-01  
LIGHT BRICK



EF-02  
DARK BRICK



EF-03  
CONCRETE FINISH  
1



EF-04  
CONCRETE FINISH  
2

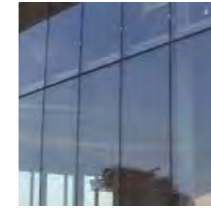

EF-05  
GLAZING



EF-06 DARK  
CLADDING



EF-07 DARK  
POWDERCOAT  
FINISH



EF-08 GREY  
POWDERCOAT  
FINISH



EF-09 LIGHT  
POWDERCOAT  
FINISH



01 Elevation North  
1:400



02 Elevation East  
1:400



DKO Architecture (QLD) Pty Ltd  
Level 3, 232 Adelaide Street  
Brisbane, QLD 4000  
ABN: 61413783636

T +61 7 3726 9588  
info@DKO.com.au  
www.DKO.com.au

© DKO Architecture (QLD) Pty Ltd  
Except as allowed under copyright act, no part of this  
drawing may be reproduced or otherwise dealt with  
without written permission of DKO Architecture.

Project Name  
Project Number  
Date  
Scale

CARSELDINE  
COMMUNITY HOUSING  
00013408  
19/08/2024  
1:400@A3

Drawing Name  
Drawing Number  
Revision

N & E Elevations  
**DA400**  
**A**



## Appendix B – Survey Plan

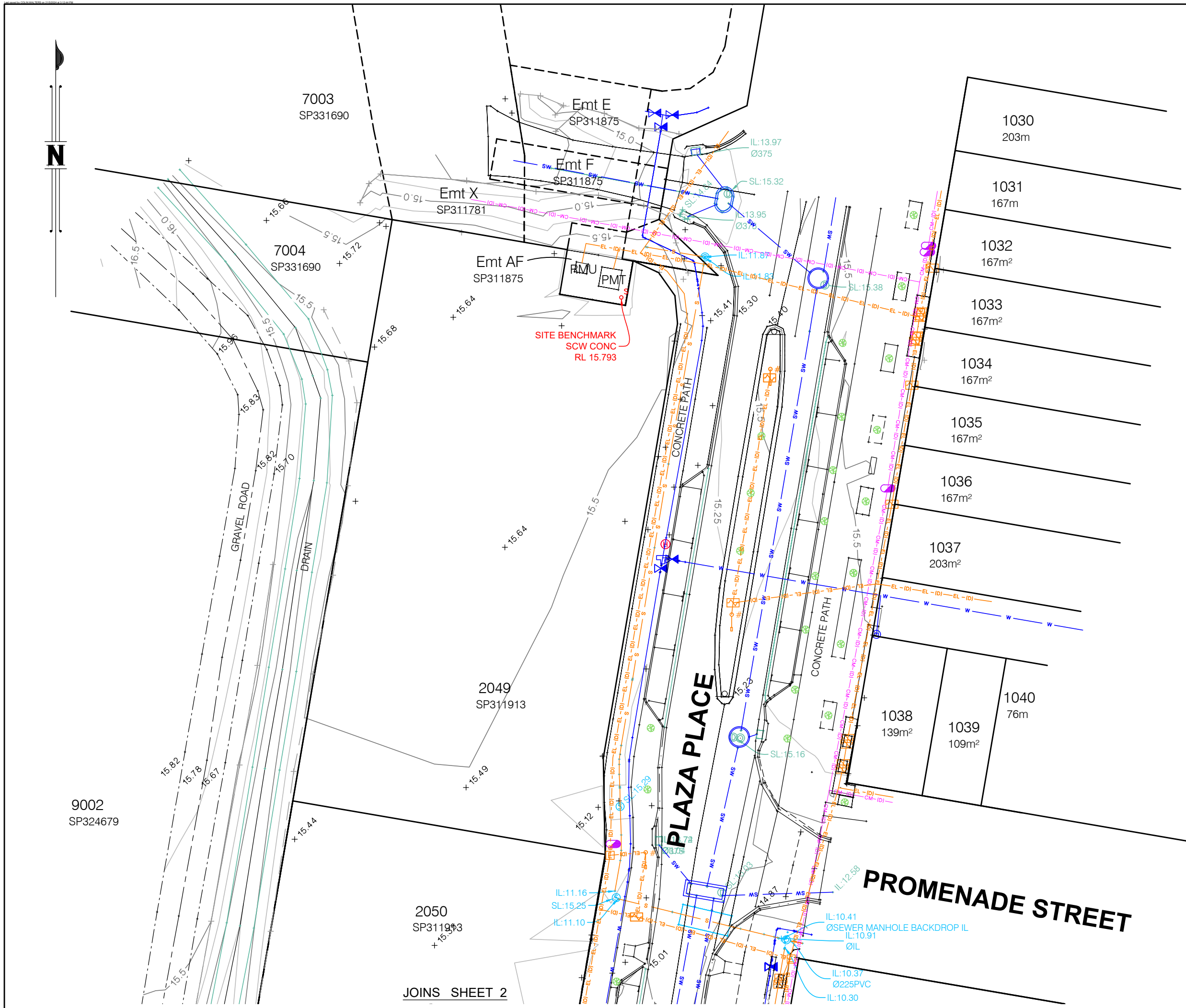

CLIENT  
**ST GEORGE  
 COMMUNITY HOUSING  
 LIMITED**

PROJECT  
**DETAIL SURVEY  
 OF  
 LOTS 2049 & 2050 ON  
 SP311913  
 (41 & 49 PLAZA PLACE, CARSELDINE)**

NOTES  
 (i) The title boundaries shown hereon were not marked at the time of survey and have been determined by plan dimensions only and not by field survey.  
 (ii) Services shown hereon have been located where possible by field survey. If not able to be so located, services have been plotted from the records of relevant authorities where available and have been noted accordingly on the plan. Where such records do not exist or are inadequate a notation has been made hereon.  
 (iii) Prior to any demolition, excavation or construction on the site, the relevant authority should be contacted for possible location of further underground services and detailed locations of all services.

|   |     |          |                |
|---|-----|----------|----------------|
| 1 | CGW | 21/05/24 | ORIGINAL ISSUE |
|---|-----|----------|----------------|

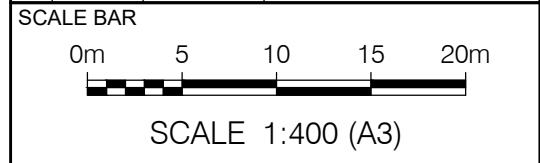

Brisbane Office  
 Level 1  
 18 Little Cribb Street  
 Milton QLD 4064

PO Box 1399  
 Milton  
 QLD 4064

p: (07) 3842 1000  
 f: (07) 3842 1001  
 e: info@landpartners.com.au  
 w: www.landpartners.com.au

|                                  |                                  |                    |                    |
|----------------------------------|----------------------------------|--------------------|--------------------|
| HEIGHT DATUM<br>AHD D            | LOCAL AUTHORITY<br>BRISBANE C.C. |                    |                    |
| HEIGHT ORIGIN<br>-               | SCALE<br>1:400 (A3)              |                    |                    |
| MERIDIAN<br>SP311913             | CONTOUR INTERVAL<br>0.25 Metre   |                    |                    |
| CO-ORD SYSTEM<br>Arbitrary Plane | DRAWN<br>CGW                     | DATE<br>21/05/2024 |                    |
| SURVEYOR<br>TJN                  | SURVEY DATE<br>14/05/24          | CHECKED<br>LHS     | DATE<br>21/05/2024 |
| FIELD FILE<br>BRLS5464-SCH-3-1   | APPROVED<br>LHS                  | DATE<br>21/05/2024 |                    |

UDN  
**BRLS5464-SCH-5-1**

SHEET 1 OF 2

JOINS SHEET 2



9002  
SP324679

JOINS SHEET 1  
2049  
SP311913

2050  
SP311913

3001  
SP324677

3000  
SP324677

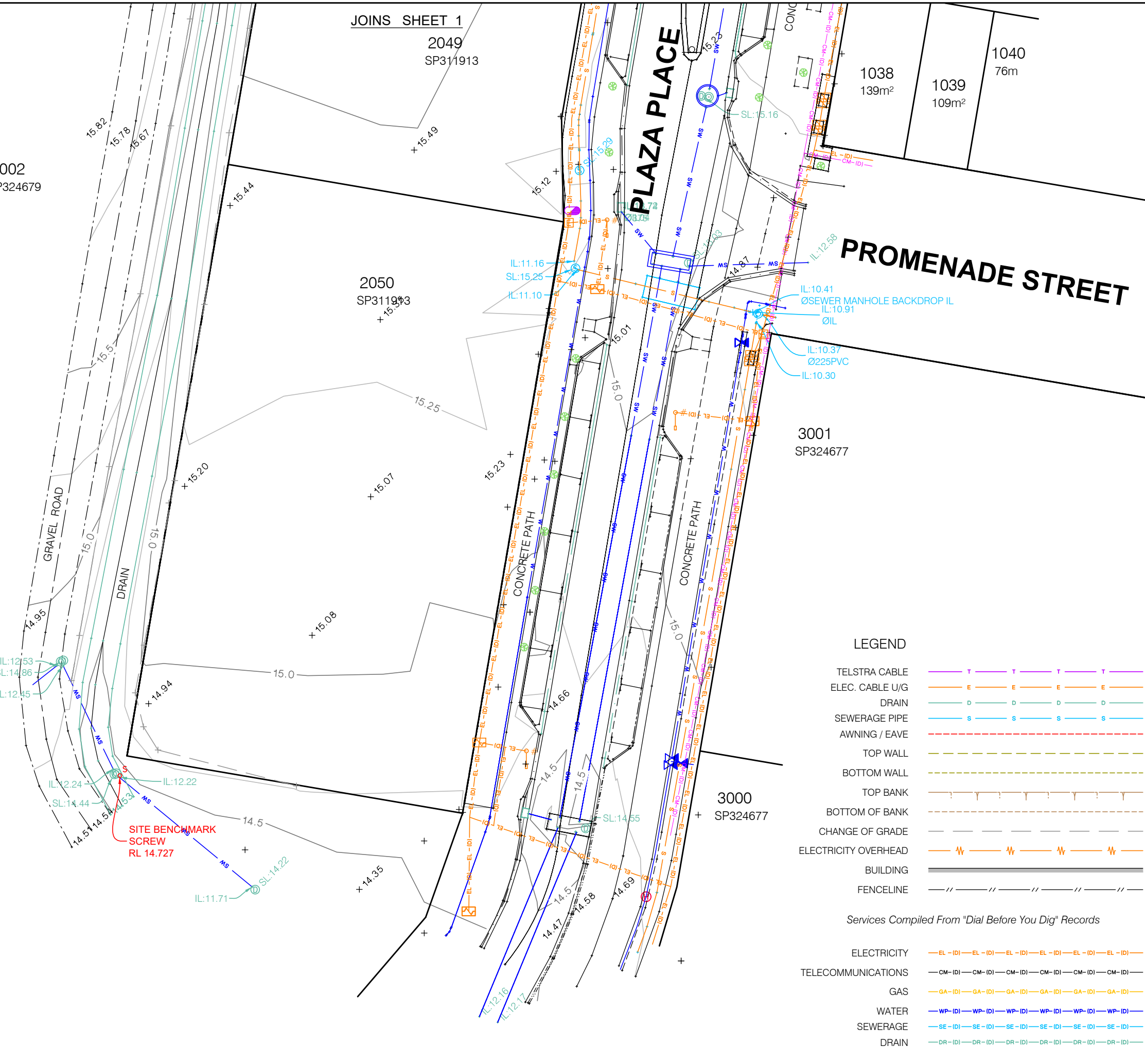

LEGEND

- TELSTRA CABLE
  - ELEC. CABLE U/G
  - DRAIN
  - SEWERAGE PIPE
  - AWNING / EAVE
  - TOP WALL
  - BOTTOM WALL
  - TOP BANK
  - BOTTOM OF BANK
  - CHANGE OF GRADE
  - ELECTRICITY OVERHEAD
  - BUILDING
  - FENCELINE
- Services Compiled From "Dial Before You Dig" Records*
- ELECTRICITY
  - TELECOMMUNICATIONS
  - GAS
  - WATER
  - SEWERAGE
  - DRAIN

CLIENT  
**ST GEORGE  
COMMUNITY HOUSING  
LIMITED**

PROJECT  
**DETAIL SURVEY  
OF  
LOTS 2049 & 2050 ON  
SP311913  
(41 & 49 PLAZA PLACE, CARSELDINE)**

NOTES  
(i) The title boundaries shown hereon were not marked at the time of survey and have been determined by plan dimensions only and not by field survey.  
(ii) Services shown hereon have been located where possible by field survey. If not able to be so located, services have been plotted from the records of relevant authorities where available and have been noted accordingly on the plan. Where such records do not exist or are inadequate a notation has been made hereon.  
(iii) Prior to any demolition, excavation or construction on the site, the relevant authority should be contacted for possible location of further underground services and detailed locations of all services.

|   |     |          |                |
|---|-----|----------|----------------|
| 1 | CGW | 21/05/24 | ORIGINAL ISSUE |
|---|-----|----------|----------------|

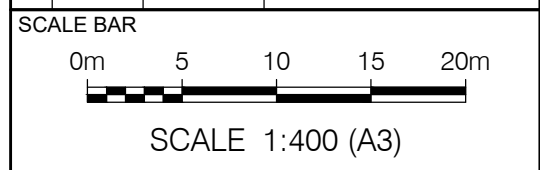

**LANDPARTNERS**  
surveyors and planners

Brisbane Office  
Level 1  
18 Little Cribb Street  
Milton QLD 4064

PO Box 1399  
Milton  
QLD 4064

p: (07) 3842 1000  
f: (07) 3842 1001  
e: info@landpartners.com.au  
w: www.landpartners.com.au

|                                  |                                  |                    |                    |
|----------------------------------|----------------------------------|--------------------|--------------------|
| HEIGHT DATUM<br>AHD D            | LOCAL AUTHORITY<br>BRISBANE C.C. |                    |                    |
| HEIGHT ORIGIN<br>-               | SCALE<br>1:400 (A3)              |                    |                    |
| MERIDIAN<br>SP311913             | CONTOUR INTERVAL<br>0.25 Metre   |                    |                    |
| CO-ORD SYSTEM<br>Arbitrary Plane | DRAWN<br>CGW                     | DATE<br>21/05/2024 |                    |
| SURVEYOR<br>TJN                  | SURVEY DATE<br>14/05/24          | CHECKED<br>LHS     | DATE<br>21/05/2024 |
| FIELD FILE<br>BRLS5464-SCH-3-1   | APPROVED<br>LHS                  | DATE<br>21/05/2024 |                    |

UDN  
**BRLS5464-SCH-5-1**



## Appendix C – Civil Works Drawings

**LEGEND**

|  |  |
|--|--|
|  | EXISTING PROPERTY BOUNDARY             |
|  | PROPOSED PROPERTY BOUNDARY             |
|  | EXISTING CONTOURS (AT 0.25m INTERVALS) |
|  | DESIGN CONTOURS (AT 0.10m INTERVALS)   |
|  | EXISTING KERB                          |
|  | EXISTING ROAD CENTRELINE               |
|  | EXISTING EDGE OF BITUMEN               |
|  | EXISTING STORMWATER                    |
|  | EXISTING SEWER                         |
|  | EXISTING WATER                         |
|  | EXISTING BATTER TOP                    |
|  | EXISTING BATTER TOE                    |
|  | PROPOSED RETAINING WALL                |
|  | RETAINING WALL HEIGHTS                 |
|  | FINISHED FLOOR LEVEL                   |
|  | FINISHED SURFACE LEVEL                 |
|  | EXISTING SURFACE LEVEL                 |
|  | FINISHED SURFACE SLOPE                 |

**CUT & FILL LEGEND**

| EXCAVATION | FILLING |
|------------|---------|
|            |         |
|            |         |
|            |         |
|            |         |
|            |         |
|            |         |
|            |         |
|            |         |

**EARTHWORKS VOLUMES**  
(STRIPPED EXISTING SURFACE TO EARTHWORKS SURFACE, ALLOWANCE FOR 150mm SLAB AND 150mm TOPSOIL STRIP)

|                 |        |
|-----------------|--------|
| TOTAL CUT       | 22m³   |
| TOTAL FILL      | 1927m³ |
| IMPORT MATERIAL | 1904m³ |

**NOTE**  
THE ORIGINAL OF THIS DRAWING WAS PRODUCED USING COLOUR SEPARATION FOR GREATER CLARITY. WORKING WITH A BLACK AND WHITE COPY MAY CAUSE ERRORS. IF THIS DRAWING IS NOT COLOUR THEN YOU DO NOT HAVE THE CORRECT PRESENTATION AND SHOULD CONTACT INERTIA ENGINEERING ON (07) 3857 7868.

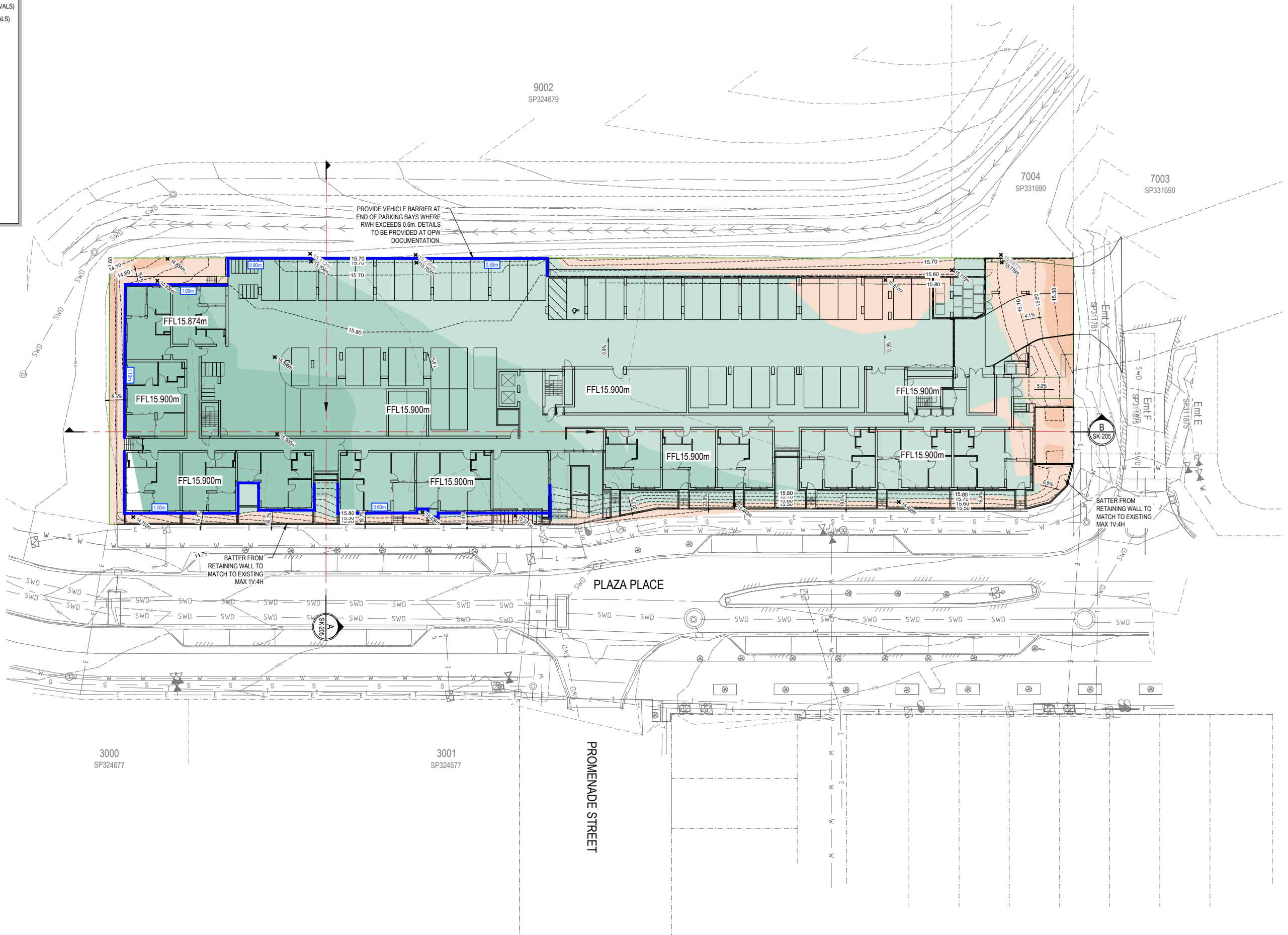

| REV | DESCRIPTION            | DATE     | DRAWN | REVIEW |
|-----|------------------------|----------|-------|--------|
| D   | ISSUED FOR APPROVAL    | 21.08.24 | HF    | AK     |
| C   | ISSUED FOR APPROVAL    | 16.08.24 | HF    | AK     |
| B   | ISSUED FOR INFORMATION | 13.06.24 | HF    | AK     |
| A   | ISSUED FOR INFORMATION | 23.05.24 | HF    | AK     |

**Inertia**  
ABN 82 115 498 023 Phone: 3857 7868  
E-mail: info@inertiaeng.com.au

CLIENT: **St George Community Housing**

ARCHITECT: **DKO**

NORTH POINT:

SCALE BARS:  
0 2 4 6 8 10 12m  
SCALE 1:250 (A1) 1:500 (A3)

PROJECT: PROPOSED DEVELOPMENT  
41-49 PLAZA PLACE  
CARSELDINE, QLD, 4034  
DRAWING TITLE: BULK EARTHWORKS  
CONCEPT LAYOUT PLAN

FOR APPROVAL  
JOB No: 10898 DWG No: SK-200 REV: D

| LEGEND |                         |
|--------|-------------------------|
|        | DESIGN SURFACE          |
|        | EXISTING SURFACE        |
|        | EARTHWORKS SURFACE      |
|        | PROPOSED RETAINING WALL |

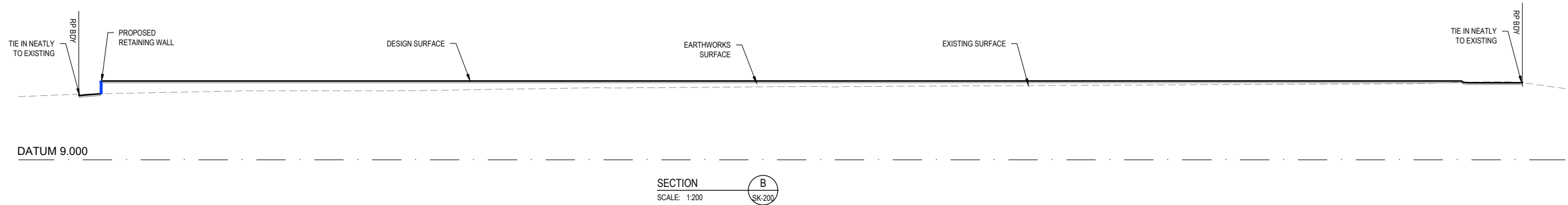
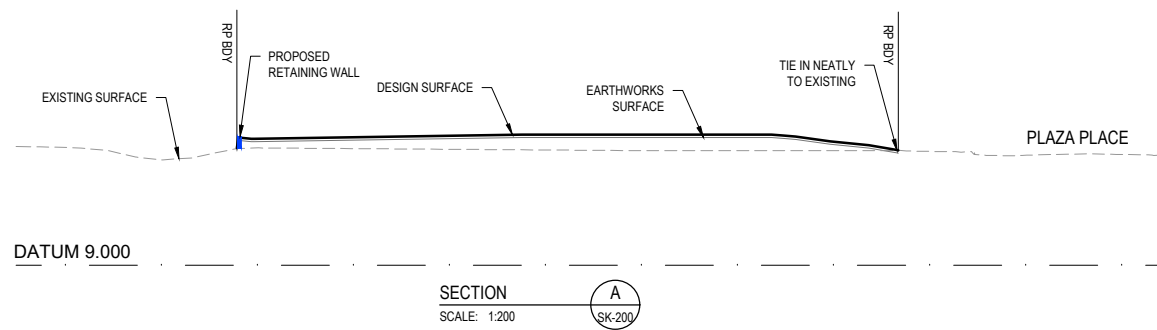

| REV | DESCRIPTION         | DATE     | DRAWN | REVIEW |
|-----|---------------------|----------|-------|--------|
| A   | ISSUED FOR APPROVAL | 16.08.24 | HF    | AK     |

**Inertia**  
 ABN 82 115 498 023 Phone: 3857 7868  
 E-mail: info@inertiaeng.com.au

CLIENT: **St George Community Housing**

ARCHITECT: **DKO**

NORTH POINT:

SCALE BARS:  
 0 2 4 6 8 10 12m  
 SCALE 1:250 (A1) 1:500 (A3)

THIS DRAWING IS TO BE PRINTED IN COLOUR REPRODUCTION OR READING OF THIS DRAWING IN OTHER THAN FULL COLOUR MAY IMPART FALSE OR MISLEADING INFORMATION

PROJECT: PROPOSED DEVELOPMENT  
 41-49 PLAZA PLACE  
 CARSELDINE, QLD, 4034

DRAWING TITLE: BULK EARTHWORKS  
 CONCEPT SITE SECTIONS

| FOR APPROVAL |            |
|--------------|------------|
| JOB No       | DWG No     |
| 10898        | SK-205 - A |

| LEGEND    |  |
|-----------|--|
|           | EXISTING PROPERTY BOUNDARY             |
|           | PROPOSED PROPERTY BOUNDARY             |
|           | EXISTING CONTOURS (AT 0.25m INTERVALS) |
|           | DESIGN CONTOURS (AT 0.25m INTERVALS)   |
|           | EXISTING KERB                          |
|           | EXISTING ROAD CENTRELINE               |
|           | EXISTING EDGE OF BITUMEN               |
|           | EXISTING STORMWATER                    |
|           | EXISTING SEWER                         |
|           | EXISTING WATER                         |
|           | EXISTING BATTER TOP                    |
|           | EXISTING BATTER TOE                    |
|           | PROPOSED STORMWATER DRAINAGE           |
|           | PROPOSED SEWER                         |
|           | PROPOSED WATER                         |
|           | PROPOSED RETAINING WALL                |
|           | PROPOSED CATCHMENT BOUNDARY            |
|           | PROPOSED PAVEMENT                      |
|           | PROPOSED FOOTPATH                      |
|           | PROPOSED BUILDING                      |
|           | PROPOSED LANDSCAPE                     |
| FFLXX.XXm | FINISHED FLOOR LEVEL                   |
|           | LEGAL POINT OF DISCHARGE               |
|           | CATCHMENT LABEL                        |
| XX.XXX *  | FINISHED SURFACE LEVEL                 |
| XX.XXX *  | EXISTING SURFACE LEVEL                 |
| X.X%      | FINISHED SURFACE SLOPE                 |

**NOTE**  
THE ORIGINAL OF THIS DRAWING WAS PRODUCED USING COLOUR SEPARATION FOR GREATER CLARITY. WORKING WITH A BLACK AND WHITE COPY MAY CAUSE ERRORS. IF THIS DRAWING IS NOT COLOUR THEN YOU DO NOT HAVE THE CORRECT PRESENTATION AND SHOULD CONTACT INERTIA ENGINEERING ON (07) 3857 7868.

**NOTE**  
THE STORMWATER DRAINAGE LAYOUT SHOWN ON THIS PLAN IS TO DEMONSTRATE SERVICEABILITY AND CLEARANCE OF PROPOSED SERVICES ONLY.

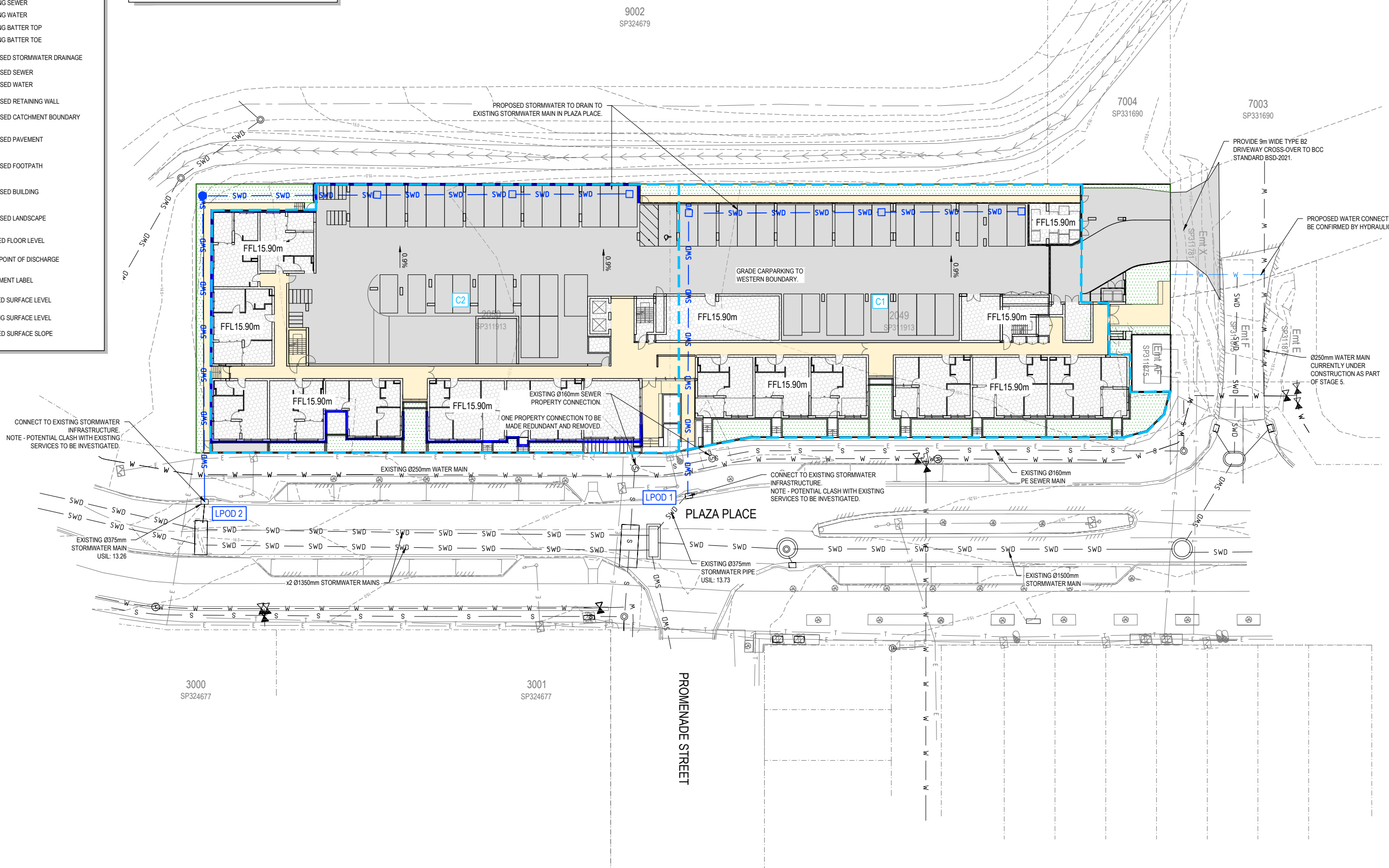

| REV | DESCRIPTION            | DATE     | DRAWN | REVIEW |
|-----|------------------------|----------|-------|--------|
| C   | ISSUED FOR APPROVAL    | 21.08.24 | HF    | AK     |
| B   | ISSUED FOR APPROVAL    | 16.08.24 | HF    | AK     |
| A   | ISSUED FOR INFORMATION | 17.07.24 | CO    | AK     |

DESIGNER  
C. OMLID  
DRAFTING QA

DESIGN QA

QA CHECKED

ABN 82 115 498 023 Phone: 3857 7868 E-mail: info@inertiaeng.com.au

CLIENT:

ARCHITECT:

NORTH POINT:

SCALE BARS:  
0 2 4 6 8 10 12m  
SCALE 1:250 (A1) 1:500 (A3)

PROJECT:  
PROPOSED DEVELOPMENT  
41-49 PLAZA PLACE  
CARSELDINE, QLD, 4034

DRAWING TITLE:  
SITE SERVICES  
CONCEPT LAYOUT PLAN

FOR APPROVAL

JOB No: 10898 DWG No: SK-600 REV: C





## Appendix D – Estate Stormwater Documentation



# CARSELDINE VILLAGE

## STAGE V (23-PNT-65389)

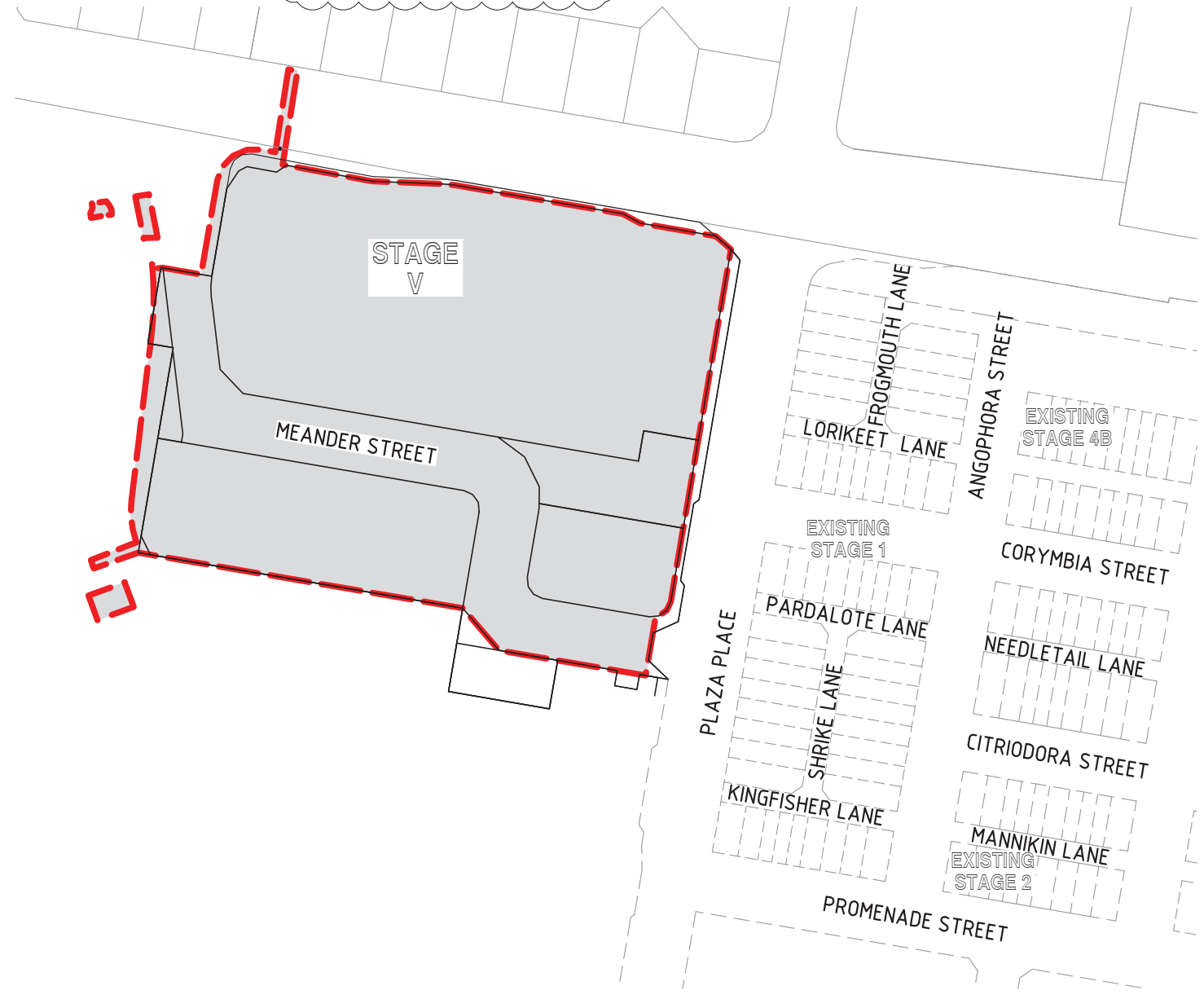

PLAN  
SCALE 1:1000

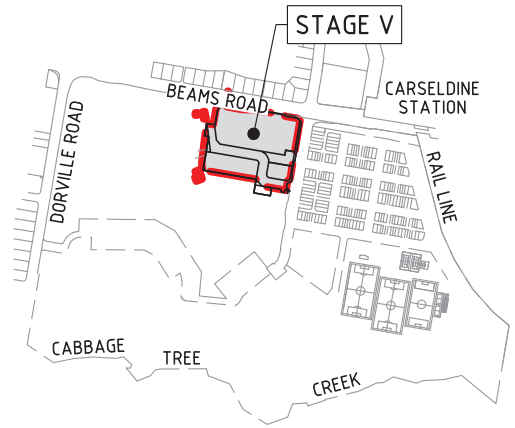

LOCALITY PLAN  
SCALE 1:7500

DO NOT SCALE THIS DRAWING  
IF IN DOUBT - ASK!



LOCALITY PLAN

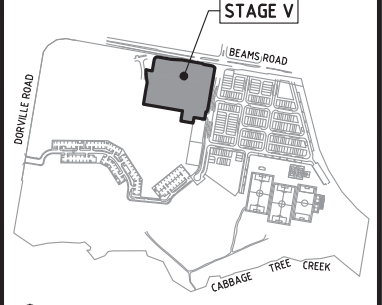

### REVISIONS

| No | Description      | Date       | By |
|----|------------------|------------|----|
| A  | FOR APPROVAL     | 12.10.2023 | RW |
| B  | QUU RFI REVISION | 24.11.2023 | RW |

Client  
**ECONOMIC DEVELOPMENT QUEENSLAND (EDQ)**

Project  
**CARSELDINE VILLAGE STAGE V**



ABN 35 112 53 611  
L1, 62 Astor Tce  
Spring Hill Q 4000  
07 3017 1900  
[www.kngroup.com.au](http://www.kngroup.com.au)

Approved  
*M. Shaw* Digitally signed by Mark Shaw RPEQ  
17544  
Date: 2023.11.21 10:54:18+1000

Drawing Title  
**GENERAL - SEWER AND WATER LOCALITY PLAN AND DRAWING INDEX**

|                   |                         |               |                   |
|-------------------|-------------------------|---------------|-------------------|
| Drawn<br>RW       | Designed<br>BK          | Checked<br>MS | Date<br>OCT '23   |
| Scale<br>AS SHOWN | Drawing No<br>21-121-51 |               | Sheet<br>51 of 20 |
| A1                | Revision<br>B           |               |                   |

### DRAWING INDEX

| DRAWING NO. | DRAWING TITLE   |
|-------------|---|
| 21-121-51   | GENERAL - SEWER AND WATER - LOCALITY PLAN AND - DRAWING INDEX |
| 21-121-52   | SEWERAGE - LAYOUT PLAN - STAGE V                              |
| 21-121-53   | SEWERAGE - NOTES - SHEET 1                                    |
| 21-121-54   | SEWERAGE - NOTES - SHEET 2                                    |
| 21-121-55   | SEWERAGE - CATCHMENT PLAN                                     |
| 21-121-56   | SEWERAGE - LONGITUDINAL SECTIONS                              |
| 21-121-57   | WATER RETICULATION - LAYOUT PLAN - STAGE V                    |
| 21-121-58   | WATER RETICULATION - NOTES                                    |
| 21-121-59   | WATER RETICULATION - LIVE CONNECTION DETAILS                  |
| 21-121-60   | WATER RETICULATION - LONGITUDINAL SECTIONS                    |
| 21-121-61   | WATER RETICULATION - LAYOUT PLAN - CH 00 TO CH 60             |
| 21-121-62   | WATER RETICULATION - WATER MAIN CONNECTION - DETAILS SHEET 1  |
| 21-121-63   | WATER RETICULATION - WATER MAIN CONNECTION - DETAILS SHEET 2  |
| 21-121-64   | WATER MAIN CONNECTION - NON-COMFORMANCE TABLE                 |



C:\Users\trw\AppData\Local\Temp\AcPublish\_56044\21-121-51-COVER.dwg Plotted by: RW on 21/11/2023 8:35:19 AM

M:\2023\2121 Carlseldine Village Stage V\Engineering\ACAD\21-211-52-55-SEW-LAYOUT.dwg Plotted by: RW on: 21/11/2023 8:35:21 AM

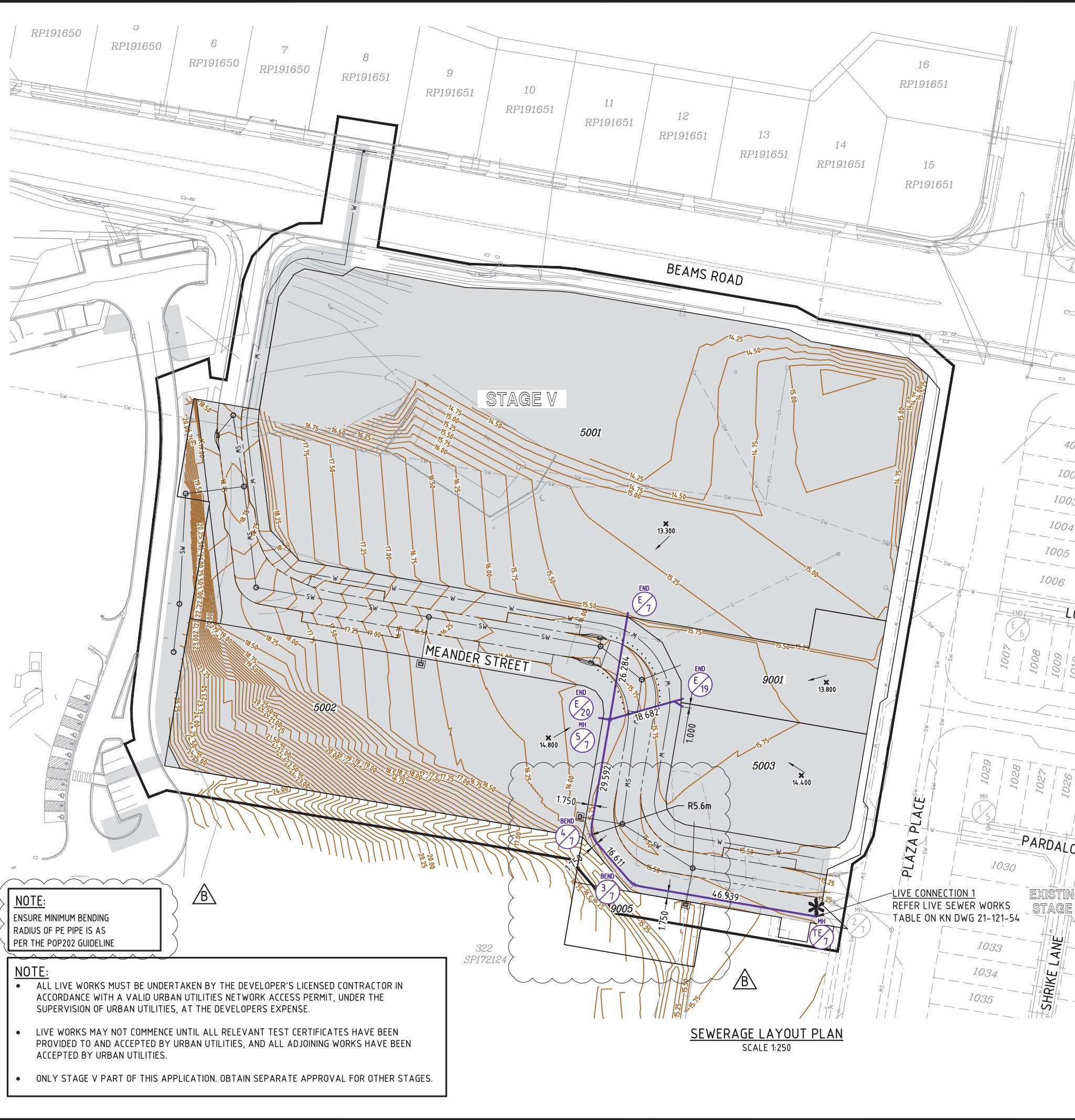

**LEGEND**

- CONSTRUCTION BOUNDARY
- PROPOSED SEWER MAIN DN160 PE100 SDR21
- PROPOSED STORMWATER MAIN
- PROPOSED WATER MAIN
- EXISTING SEWER MAIN
- EXISTING STORMWATER
- EXISTING WATER MAIN
- EXISTING ELECTRICAL
- DESIGN SURFACE CONTOURS (0.1m)
- DEFINES CONNECTION REQUIRED BY UU - REFER LIVE SEWER WORKS TABLE ON KN DWG 20-180-54
- CONTROL POINT
- FLOW ARROW

**SEWER MANHOLE LEGEND**

- |  |                   |  |                            |
|--|-------------------|--|----------------------------|
|  | MANHOLE           |  | EXISTING MANHOLE           |
|  | MAINTENANCE SHAFT |  | EXISTING MAINTENANCE SHAFT |
|  | BEND              |  | EXISTING BEND              |
|  | END OF LINE       |  | EXISTING END OF LINE       |
|  | JUNCTION          |  | EXISTING JUNCTION          |

DO NOT SCALE THIS DRAWING IF IN DOUBT - ASK!

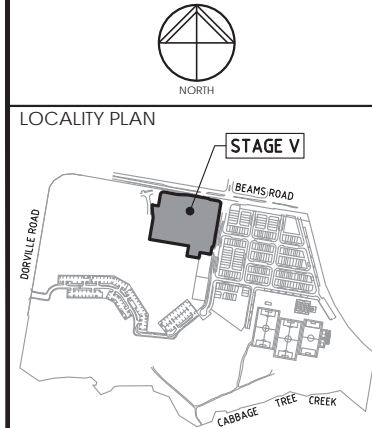

**REVISIONS**

| No | Description      | Date       | By |
|----|------------------|------------|----|
| A  | FOR APPROVAL     | 12.10.2023 | RW |
| B  | OUU RFI REVISION | 24.11.2023 | RW |

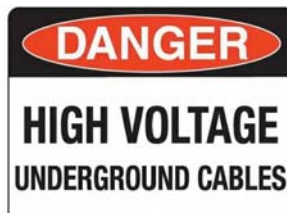

*The Essential First Step.*

**NOTE**  
ALL PROPERTY CONNECTIONS HAVE A 1.0m OFFSET FROM BOUNDARY U.N.O.

**NOTE**  
PROPERTY CONNECTIONS SHALL BE CLEAR OF RETAINING WALLS IN ACCORDANCE WITH SEQ CODE AND BUILD OVER ASSET REQUIREMENTS. OBTAIN SEPARATE BUILD OVER ASSET APPROVAL AS NECESSARY.

ALL WATER AND SEWER CONSTRUCTION WORK SHALL COMPLY WITH THE REQUIREMENTS OF THE QUEENSLAND WORK HEALTH AND SAFETY ACT 2011. CONTACT THE DIVISION OF WORKPLACE HEALTH AND SAFETY FOR INFORMATION. PHONE: 1300 362 128

PROPERTY CONNECTIONS HAVE BEEN DESIGNED TO CONTROL THE REQUIRED SERVICE AREA OF EACH LOT AT A GRADE OF 1:60 AND A MAXIMUM DEPTH OF PROPERTY CONNECTION AT 1.5m. UNLESS OTHERWISE STATED. FOR JUNCTION DETAILS REFER SEQ-SEW-1106-1 TO SEQ-SEW-1106-6.

**NOTE:**  
ENSURE MINIMUM BENDING RADIUS OF PE PIPE IS AS PER THE POP202 GUIDELINE

**NOTE:**

- ALL LIVE WORKS MUST BE UNDERTAKEN BY THE DEVELOPER'S LICENSED CONTRACTOR IN ACCORDANCE WITH A VALID URBAN UTILITIES NETWORK ACCESS PERMIT, UNDER THE SUPERVISION OF URBAN UTILITIES, AT THE DEVELOPERS EXPENSE.
- LIVE WORKS MAY NOT COMMENCE UNTIL ALL RELEVANT TEST CERTIFICATES HAVE BEEN PROVIDED TO AND ACCEPTED BY URBAN UTILITIES, AND ALL ADJOINING WORKS HAVE BEEN ACCEPTED BY URBAN UTILITIES.
- ONLY STAGE V PART OF THIS APPLICATION. OBTAIN SEPARATE APPROVAL FOR OTHER STAGES.

Client  
**ECONOMIC DEVELOPMENT QUEENSLAND (EDQ)**

Project  
**CARSELDINE VILLAGE STAGE V**



Approved  
*M. Shaw*  
Digitally signed by Mark Shaw RPEQ 17544 Date: 2023.11.21 10:54:18+1000'

Drawing Title  
**SEWERAGE LAYOUT PLAN STAGE V**

|                   |                         |               |                   |
|-------------------|-------------------------|---------------|-------------------|
| Drawn<br>RW       | Designed<br>BK          | Checked<br>MS | Date<br>OCT '23   |
| Scale<br>AS SHOWN | Drawing No<br>21-121-52 |               | Sheet<br>52 of 20 |
| A1                | Revision<br>B           |               |                   |

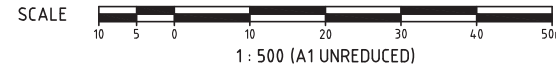





M:\2021\2121 Carselfine Village Stage V\Engineering\ACAD\21-21-52-55-SEW-LAYOUT.dwg Plotted by: RW on 21/11/2023 8:35:23 AM



**SEWERAGE CATCHMENT PLAN**  
SCALE 1:500

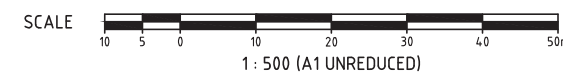

DO NOT SCALE THIS DRAWING  
IF IN DOUBT - ASK!



LOCALITY PLAN

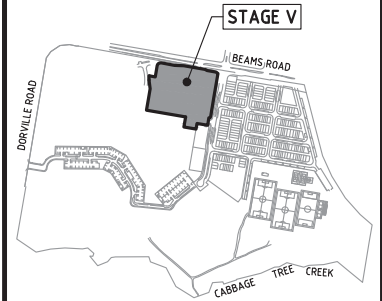

REVISIONS

| No | Description      | Date       | By |
|----|------------------|------------|----|
| A  | FOR APPROVAL     | 12.10.2023 | RW |
| B  | QUU RFI REVISION | 24.11.2023 | RW |
|    |                  |            |    |
|    |                  |            |    |
|    |                  |            |    |
|    |                  |            |    |
|    |                  |            |    |
|    |                  |            |    |
|    |                  |            |    |

Client

ECONOMIC  
DEVELOPMENT  
QUEENSLAND (EDQ)

Project

CARSELDINE VILLAGE  
STAGE V



ABN 35 112 53 611  
L1, 62 Astor Tce  
Spring Hill Q 4000  
07 3017 1900  
www.kngroup.com.au

Approved

Digitally signed by  
Mark Shaw RPEQ  
17544  
Date: 2023.11.21  
10:54:19+1000'

Drawing title

SEWERAGE  
CATCHMENT PLAN

| Drawn    | Designed   | Checked | Date     |
|----------|------------|---------|----------|
| RW       | BK         | MS      | OCT '23  |
| Scale    | Drawing No |         | Sheet    |
| AS SHOWN | 21-121-55  |         | 55 of 20 |
| A1       | Revision   |         | B        |

DO NOT SCALE THIS DRAWING  
IF IN DOUBT - ASK!

LOCALITY PLAN

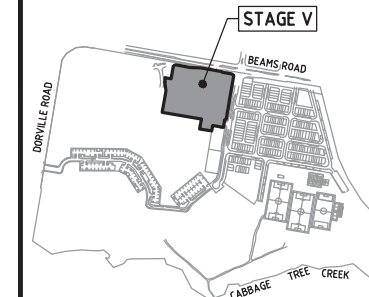

REVISIONS

| No | Description      | Date       | By |
|----|------------------|------------|----|
| A  | FOR APPROVAL     | 12.10.2023 | RW |
| B  | QUU RFI REVISION | 24.11.2023 | RW |
| C  | QUU RFI REVISION | 14.12.2023 | RW |

Client

ECONOMIC  
DEVELOPMENT  
QUEENSLAND (EDQ)

Project

CARSELDINE VILLAGE  
STAGE V



Approved  
*M. Shaw*  
Mark Andrew Shaw BEng  
(Civil), MIEAust, RPEQ  
17544  
2023.12.14 15:07:34  
+1000

Drawing Title  
SEWERAGE  
LONGITUDINAL SECTIONS

|                   |                         |               |                   |
|-------------------|-------------------------|---------------|-------------------|
| Drawn<br>RW       | Designed<br>BK          | Checked<br>MS | Date<br>OCT '23   |
| Scale<br>AS SHOWN | Drawing No<br>21-121-56 |               | Sheet<br>56 of 20 |
| A1                | Revision<br>C           |               |                   |

|                                |
|--------------------------------|
| MAINTENANCE HOLE/SHAFT No.     |
| MH/MS COVER TYPE               |
| MH/MS TYPE                     |
| MH/MS DROP TYPE                |
| BRANCH LINE No.                |
| HC TYPE                        |
| HC DEPTH                       |
| HC CH. TO DS MH/MS/<br>FITTING |
| HC INVERT LEVEL                |
| HC LOT No.                     |

LEGEND:

- G = CONCRETE 0.900Ø MH
- F = CONCRETE 1.200Ø MH
- X = CONCRETE 1.200Ø MH
- @ = PE LINED SEQ-SPS-14.07-1A & 2B
- & = CONNECTION FROM MANHOLE
- MS = MAINTENANCE SHAFT

- B = CLASS B NON-TRAFFICABLE
- D = CLASS D TRAFFICABLE

NOTES:

- PROPERTY CONNECTION TYPE/DETAILS REFER SEQ-SEW-1106 DWG SERIES.
- MANHOLE TYPE/DETAILS REFER SEQ-SEW-1301-1 TO 1301-21, 1304-1 TO 1305-1, 1308-2 TO 1308-11, 1313-1, 1316-1.
- WHERE CLASS "D" COVERS ARE SPECIFIED FOR MH OR MS, INCREASE TOP SLAB THICKNESS FROM 150mm TO 175mm.
- COMPLETE ALL END OF LINE WITH A ELECTROFUSION STOP END OR BUTT WELDED CAP. REFER WSAA GRAVITY SEWERAGE CODE OF AUSTRALIA - SEQ-EDITION - VERSION 2.1 (SEPTEMBER 2021)

# DENOTES BRIDGING STRUCTURE BETWEEN STORMWATER AND SEWER MAIN REFER TYPICAL BRIDGING DETAIL ON GC STRUCTURAL ENGINEERS DWG 23ST368\_S001

DATUM RL

|                                 |
|---------------------------------|
| LOCATION                        |
| PIPE DIAMETER                   |
| GRADE                           |
| LENGTH                          |
| EMBEDMENT TYPE                  |
| JUNCTION                        |
| INVERT LEVEL                    |
| DEPTH OF INVERT<br>BELOW FSL    |
| INVERT LEVEL (IL)               |
| FINISHED SURFACE<br>LEVEL (FSL) |
| EXISTING SURFACE<br>LEVEL (ESL) |
| CHAINAGE (CH)                   |

LINE

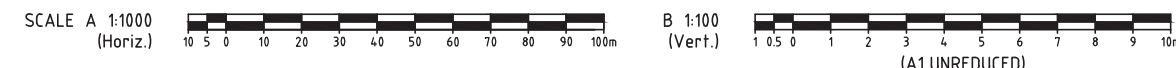
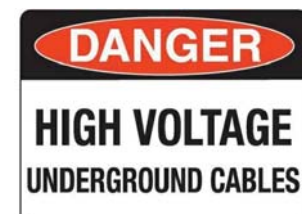
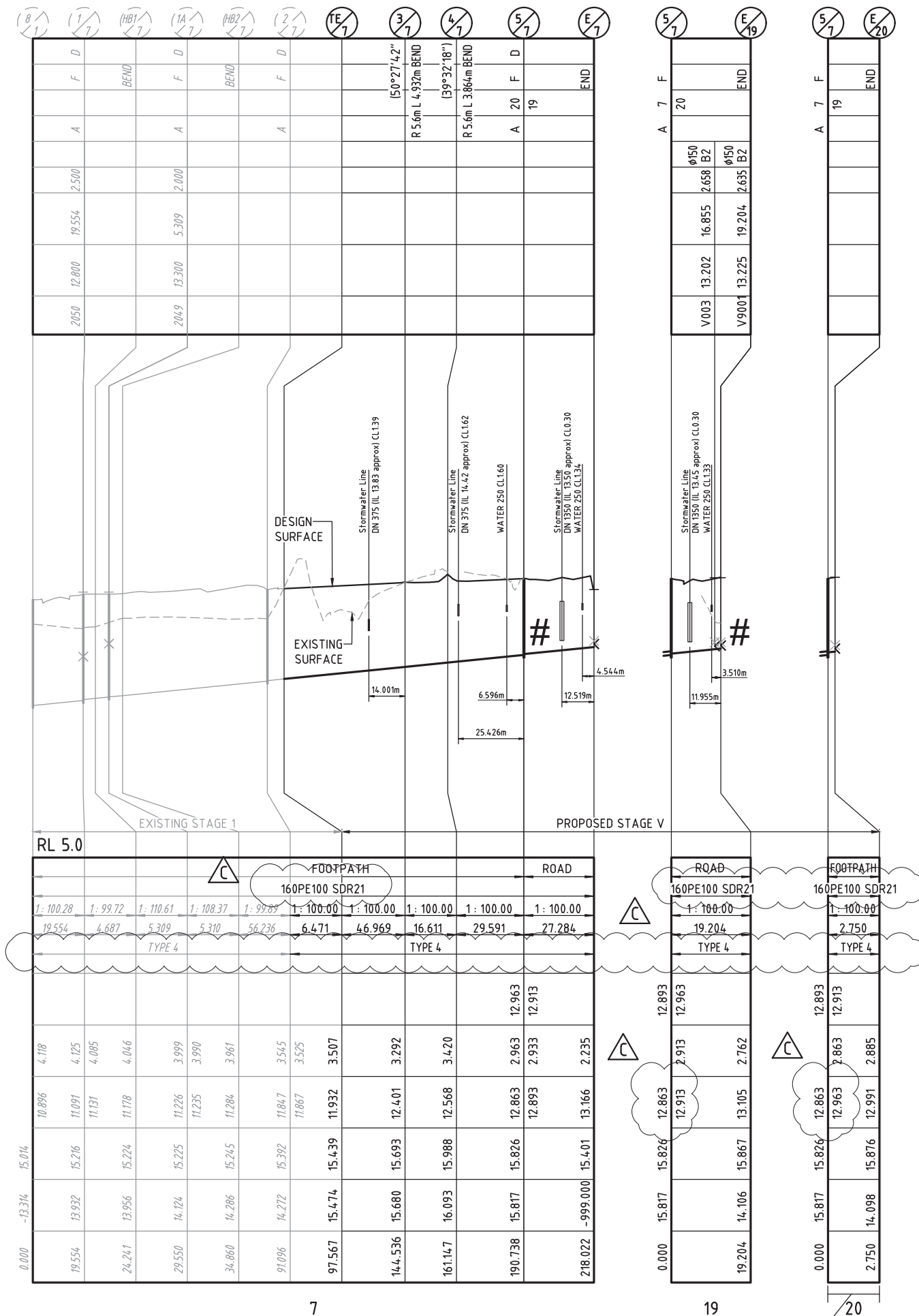

C:\Users\m.v\AppData\Local\Temp\AcPublish...11556\31-121-56-SEW-LONG.dwg Plotted by: RW on 14/12/2023 2:58:22 PM

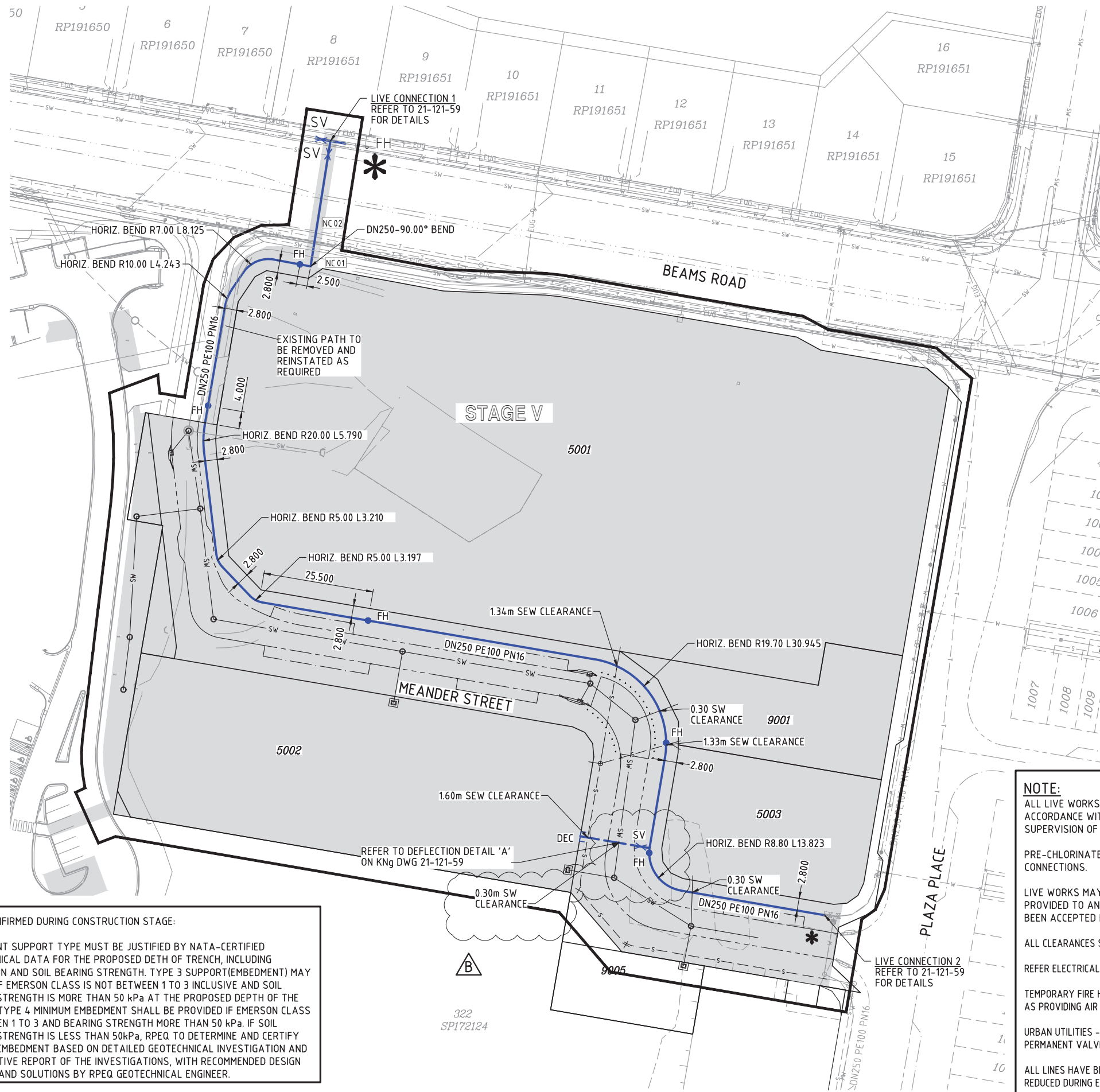

**LEGEND**

- CONSTRUCTION BOUNDARY
- PROPOSED DN250 PE100 PN16 WATER MAIN
- PROPOSED DN125 PE100 PN16 WATER MAIN
- PROPOSED CONDUIT
- EXISTING WATER MAIN
- STORMWATER DRAINAGE
- SEWER MAIN
- EXISTING STORMWATER MAIN
- EXISTING SEWER MAIN
- EXISTING ELECTRICAL
- FIRE HYDRANT
- SECTION VALVE
- SCOUR VALVE
- REDUCER
- DEAD END CAP
- LIVE CONNECTION TO BE COMPLETED BY CONTRACTOR UNDER UU SUPERVISION

DO NOT SCALE THIS DRAWING IF IN DOUBT - ASK!

NORTH

LOCALITY PLAN

REVISIONS

| No | Description      | Date       | By |
|----|------------------|------------|----|
| A  | FOR APPROVAL     | 12.10.2023 | RW |
| B  | QUU RFI REVISION | 24.11.2023 | RW |

**NOTE:**  
 ALL VALVES & HYDRANTS TO BE LOCATED CLEAR OF ROADWAYS AND CONCRETE HARDSTANDS. ALL WATER METERS & FIRE HYDRANTS TO BE MIN 1.1m CLEAR OF ENERGEX PILLARS.

**NOTE:**  
 ALL LIVE WORKS MUST BE UNDERTAKEN BY THE DEVELOPER'S LICENSED CONTRACTOR IN ACCORDANCE WITH A VALID URBAN UTILITIES NETWORK ACCESS PERMIT, UNDER THE SUPERVISION OF URBAN UTILITIES, AT THE DEVELOPERS EXPENSE.

PRE-CHLORINATED FITTINGS SHALL BE USED FOR WATER SUPPLY LIVE-WORKS CONNECTIONS.

LIVE WORKS MAY NOT COMMENCE UNTIL ALL RELEVANT TEST CERTIFICATES HAVE BEEN PROVIDED TO AND ACCEPTED BY URBAN UTILITIES, AND ALL ADJOINING WORKS HAVE BEEN ACCEPTED BY URBAN UTILITIES.

ALL CLEARANCES SHOWN BETWEEN OTHER SERVICES ARE VERTICAL CLEARANCE U.N.O

REFER ELECTRICAL CONSULTANTS DRAWINGS FOR ELECTRICAL PILLAR LOCATIONS.

TEMPORARY FIRE HYDRANTS HAVE BEEN UTILISED TO ALLOW FLUSHING TO END OF LINES AS WELL AS PROVIDING AIR RELEASE FOR MAINTENANCE IF REQUIRED.

URBAN UTILITIES - DO NOT ACCEPT SCOURS ON SYSTEM AND DUE TO THE LOCATION OF THE PERMANENT VALVES, BOTH FITTINGS HAVE BEEN REMOVED FROM THE END OF LINE TREATMENT

ALL LINES HAVE BEEN EXTENDED BY MIN. 5m PAST LAST LOT TO ENSURE FUTURE DISTURBANCE IS REDUCED DURING EXTENSION OF SERVICES

WATERMAIN TO BE JOINT-FREE FOR A LENGTH EQUAL TO THE DIAMETER OF THE MAINTENANCE STRUCTURE PLUS 1m EXTENDING FROM EACH SIDE.

TO BE CONFIRMED DURING CONSTRUCTION STAGE:

EMBEDMENT SUPPORT TYPE MUST BE JUSTIFIED BY NATA-CERTIFIED GEOTECHNICAL DATA FOR THE PROPOSED DETH OF TRENCH, INCLUDING DISPERSION AND SOIL BEARING STRENGTH. TYPE 3 SUPPORT(EMBEDMENT) MAY BE USED IF EMERSON CLASS IS NOT BETWEEN 1 TO 3 INCLUSIVE AND SOIL BEARING STRENGTH IS MORE THAN 50 kPa AT THE PROPOSED DEPTH OF THE SERVICE. TYPE 4 MINIMUM EMBEDMENT SHALL BE PROVIDED IF EMERSON CLASS IS BETWEEN 1 TO 3 AND BEARING STRENGTH MORE THAN 50 kPa. IF SOIL BEARING STRENGTH IS LESS THAN 50kPa, RPEQ TO DETERMINE AND CERTIFY TYPE OF EMBEDMENT BASED ON DETAILED GEOTECHNICAL INVESTIGATION AND INTERPRETIVE REPORT OF THE INVESTIGATIONS, WITH RECOMMENDED DESIGN CRITERIA AND SOLUTIONS BY RPEQ GEOTECHNICAL ENGINEER.

WATER RETICULATION LAYOUT PLAN  
 SCALE 1:500

SCALE

1 : 500 (A1 UNREDUCED)

Client

ECONOMIC DEVELOPMENT QUEENSLAND (EDQ)

Project

CARSELDINE VILLAGE STAGE V

ABN 35 112 53 611  
 L1, 62 Astor Tce  
 Spring Hill Q 4000  
 07 3017 1900  
 www.kngroup.com.au

Approved

*M. Shaw* Digitally signed by Mark Shaw RPEQ 17544 Date: 2023.11.21 10:54:20+1000'

Drawing Title

WATER RETICULATION LAYOUT PLAN STAGE V

|                   |                         |               |                   |
|-------------------|-------------------------|---------------|-------------------|
| Drawn<br>RW       | Designed<br>JB          | Checked<br>MS | Date<br>OCT '23   |
| Scale<br>AS SHOWN | Drawing No<br>21-121-57 |               | Sheet<br>57 of 20 |
| A1                | Revision<br>B           |               |                   |

K:\2021\2121 Careldine Village Stage V\Engineering\ACAD\21-121-57-64-WATER.dwg Plotted by: RW on 21/11/2023 8:35:25 AM





K:\2021\2121 Carlseldine Village Stage V\Engineering\ACAD\21-121-51-64-WATER.dwg Plotted by: RW on 21/11/2023 8:35:30 AM

DO NOT SCALE THIS DRAWING  
IF IN DOUBT - ASK!



LOCALITY PLAN

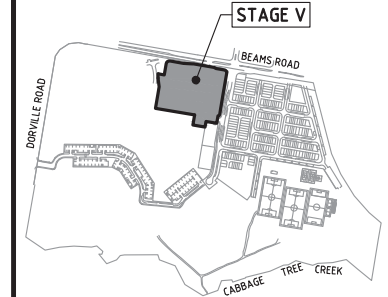

REVISIONS

| No | Description      | Date       | By |
|----|------------------|------------|----|
| A  | FOR APPROVAL     | 12.10.2023 | RW |
| B  | QUU RFI REVISION | 24.11.2023 | RW |
|    |                  |            |    |
|    |                  |            |    |
|    |                  |            |    |
|    |                  |            |    |
|    |                  |            |    |
|    |                  |            |    |
|    |                  |            |    |
|    |                  |            |    |
|    |                  |            |    |
|    |                  |            |    |

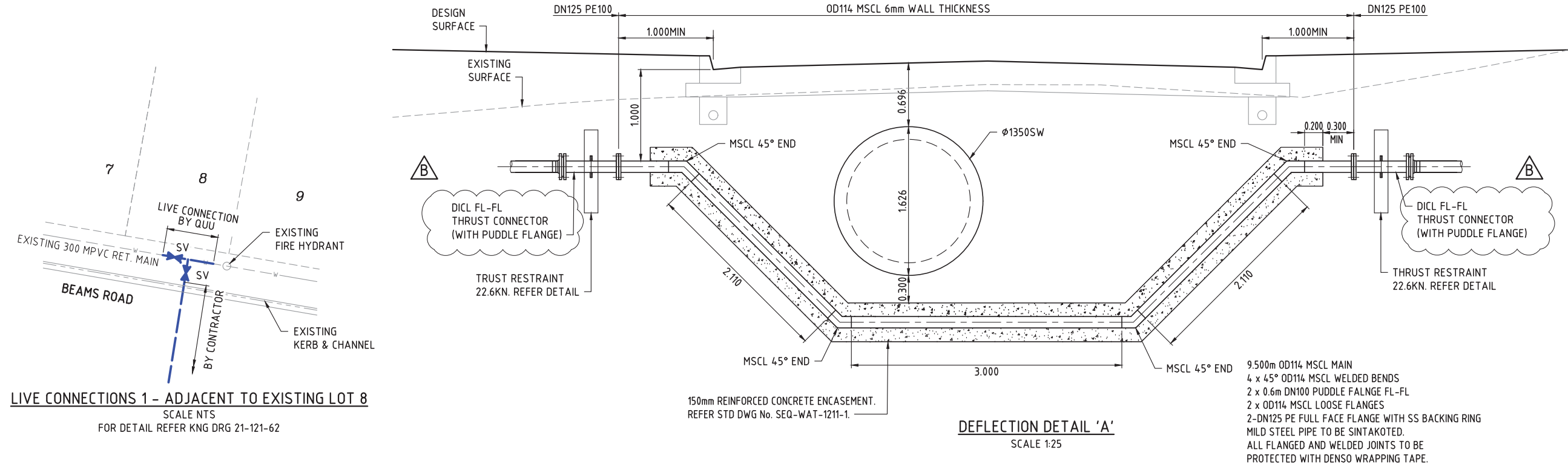

**LIVE CONNECTIONS 1 - ADJACENT TO EXISTING LOT 8**  
SCALE NTS  
FOR DETAIL REFER KNG DRG 21-121-62

**DEFLECTION DETAIL 'A'**  
SCALE 1:25

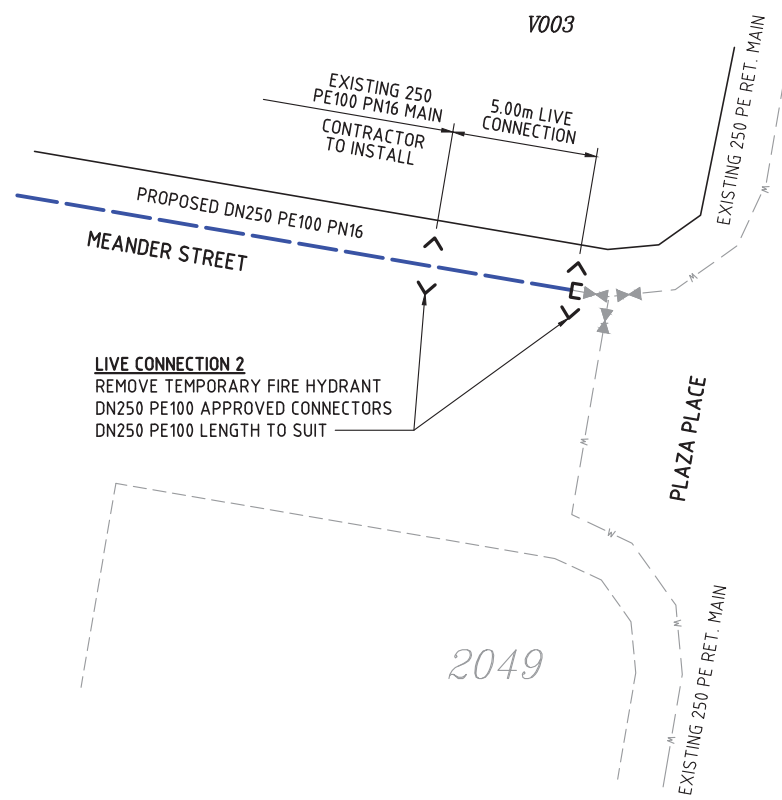

**LIVE CONNECTIONS 2 - ADJACENT TO EXISTING LOT 2049**  
SCALE NTS

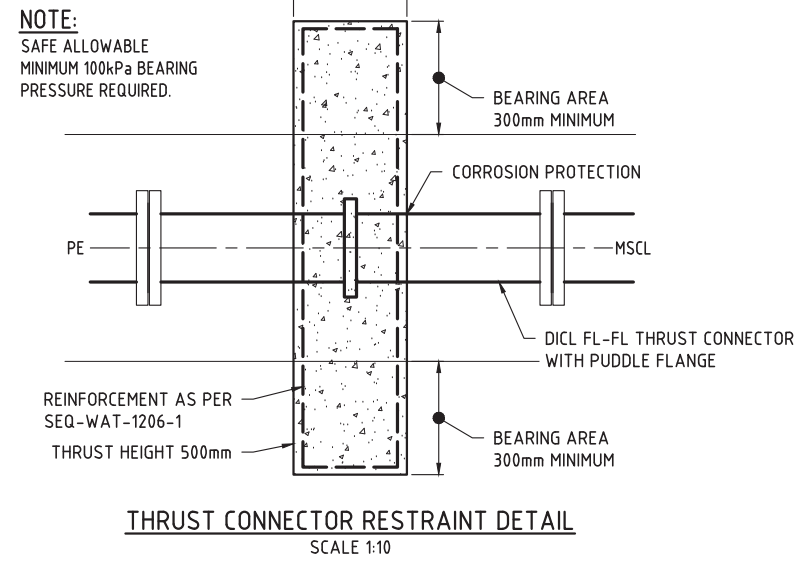

**THRUST CONNECTOR RESTRAINT DETAIL**  
SCALE 1:10

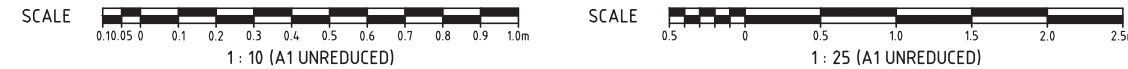

Client

ECONOMIC DEVELOPMENT QUEENSLAND (EDQ)

Project

CARSELDINE VILLAGE STAGE V



Approved

Digitally signed by Mark Shaw RPEQ 17544 Date: 2023.11.21 10:54:21+1000'

Drawing Title

WATER RETICULATION LIVE CONNECTION DETAILS

|                   |                |                   |                 |
|-------------------|----------------|-------------------|-----------------|
| Drawn<br>RW       | Designed<br>JB | Checked<br>MS     | Date<br>OCT '23 |
| Scale<br>AS SHOWN |                | Sheet<br>59 of 20 |                 |
| Drawing No<br>A1  |                | Revision<br>B     |                 |

DO NOT SCALE THIS DRAWING  
IF IN DOUBT - ASK!



LOCALITY PLAN

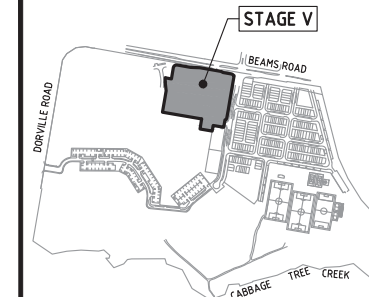

REVISIONS

| No | Description      | Date       | By |
|----|------------------|------------|----|
| A  | FOR APPROVAL     | 12.10.2023 | RW |
| B  | OUU RFI REVISION | 24.11.2023 | RW |

Vertical Geometry Grade  
Vertical Geometry Length (m)

MATERIAL TYPE

DATUM R.L. 2.000

|                        |        |        |        |        |        |        |        |        |        |        |        |        |        |        |        |        |        |        |        |        |
|------------------------|--------|--------|--------|--------|--------|--------|--------|--------|--------|--------|--------|--------|--------|--------|--------|--------|--------|--------|--------|--------|
| NATURAL SURFACE (NS)   | 15.101 | 14.959 | 14.971 | 14.971 | 14.971 | 14.971 | 14.971 | 15.172 | 15.502 | 15.690 | 15.714 | 15.777 | 16.026 | 16.036 | 16.098 | 16.207 | 16.248 | 16.332 | 16.589 | 16.942 |
| DEPTH OF IL BELOW (NS) | 2.322  | 2.180  | 2.464  | 2.491  | 2.854  | 2.881  | 3.164  | 3.354  | 3.684  | 1.301  | 1.278  | 1.297  | 1.460  | 1.467  | 0.679  | 0.764  | 1.450  | 1.414  | 1.347  | 1.312  |
| INVERT LEVEL (IL)      | 12.779 | 12.779 | 12.507 | 12.480 | 12.117 | 12.090 | 11.818 | 11.818 | 11.818 | 14.389 | 14.436 | 14.480 | 14.566 | 14.569 | 15.419 | 15.443 | 14.798 | 14.918 | 15.242 | 15.630 |
| PEGGED CHAINAGE        | 0.000  | 0.905  | 1.203  | 1.205  | 1.206  | 1.208  | 1.506  | 20.000 | 29.247 | 37.836 | 40.000 | 42.000 | 45.962 | 46.100 | 46.949 | 48.449 | 49.094 | 50.672 | 54.915 | 60.000 |

Horiz Curve Data



LONGITUDINAL SECTION - WATER DN250

SCALE - 1:100 (H)  
1:100 (V)

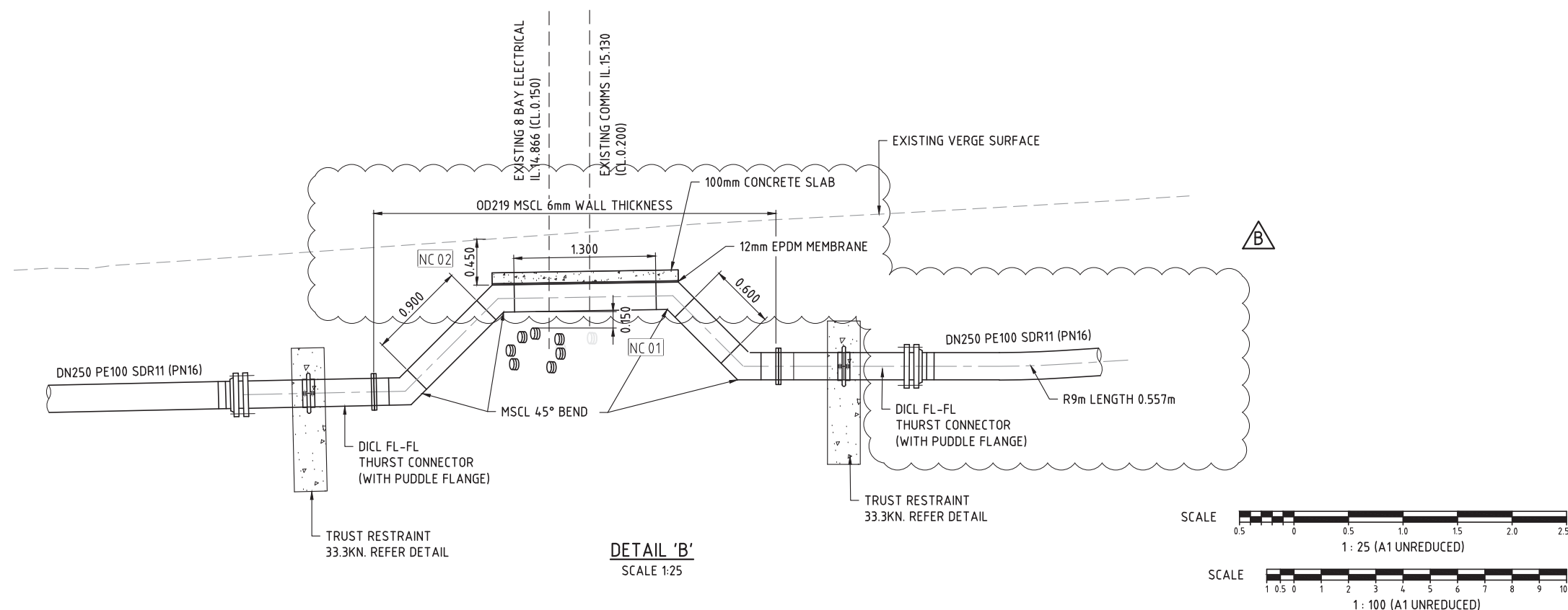

DETAIL 'B'  
SCALE 1:25

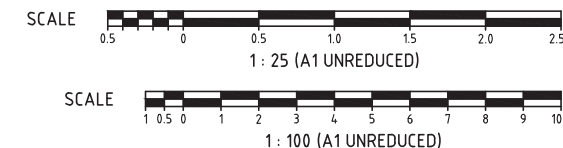

Client

ECONOMIC DEVELOPMENT QUEENSLAND (EDQ)

Project

CARSELDINE VILLAGE STAGE V



Approved

Digitally signed by Mark Shaw RPEQ 17544 Date: 2023.11.21 10:54:21+1000'

Drawing title

WATER RETICULATION LONGITUDINAL SECTIONS

| Drawn | Designed             | Checked    | Date        |
|-------|----------------------|------------|-------------|
| RW    | JB                   | MS         | OCT '23     |
| Scale | AS SHOWN             |            | Sheet 60 of |
| A1    | Drawing No 21-121-60 | Revision B |             |



DO NOT SCALE THIS DRAWING  
IF IN DOUBT - ASK!



LOCALITY PLAN

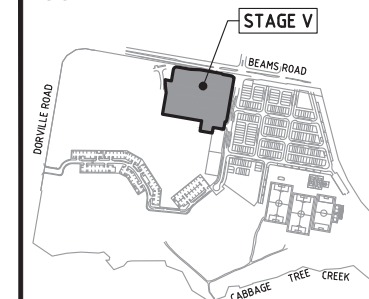

REVISIONS

| No | Description  | Date       | By |
|----|--------------|------------|----|
| A  | FOR APPROVAL | 12.10.2023 | RW |
|    |              |            |    |
|    |              |            |    |
|    |              |            |    |
|    |              |            |    |
|    |              |            |    |
|    |              |            |    |
|    |              |            |    |
|    |              |            |    |
|    |              |            |    |
|    |              |            |    |
|    |              |            |    |
|    |              |            |    |
|    |              |            |    |
|    |              |            |    |

Client  
**ECONOMIC DEVELOPMENT QUEENSLAND (EDQ)**

Project  
**CARSELDINE VILLAGE STAGE V**



Approved  
*M. Shaw* Digitally signed by Mark Shaw RPEQ 17544 Date: 2023.11.21 10:54:21+1000'

Drawing title  
**WATER RETICULATION LAYOUT PLAN  
CH 00 TO CH 60**

|                   |                         |               |                 |
|-------------------|-------------------------|---------------|-----------------|
| Drawn<br>RW       | Designed<br>JB          | Checked<br>MS | Date<br>OCT '23 |
| Scale<br>AS SHOWN |                         |               | Sheet<br>61 of  |
| A1                | Drawing No<br>21-121-61 | Revision<br>A |                 |

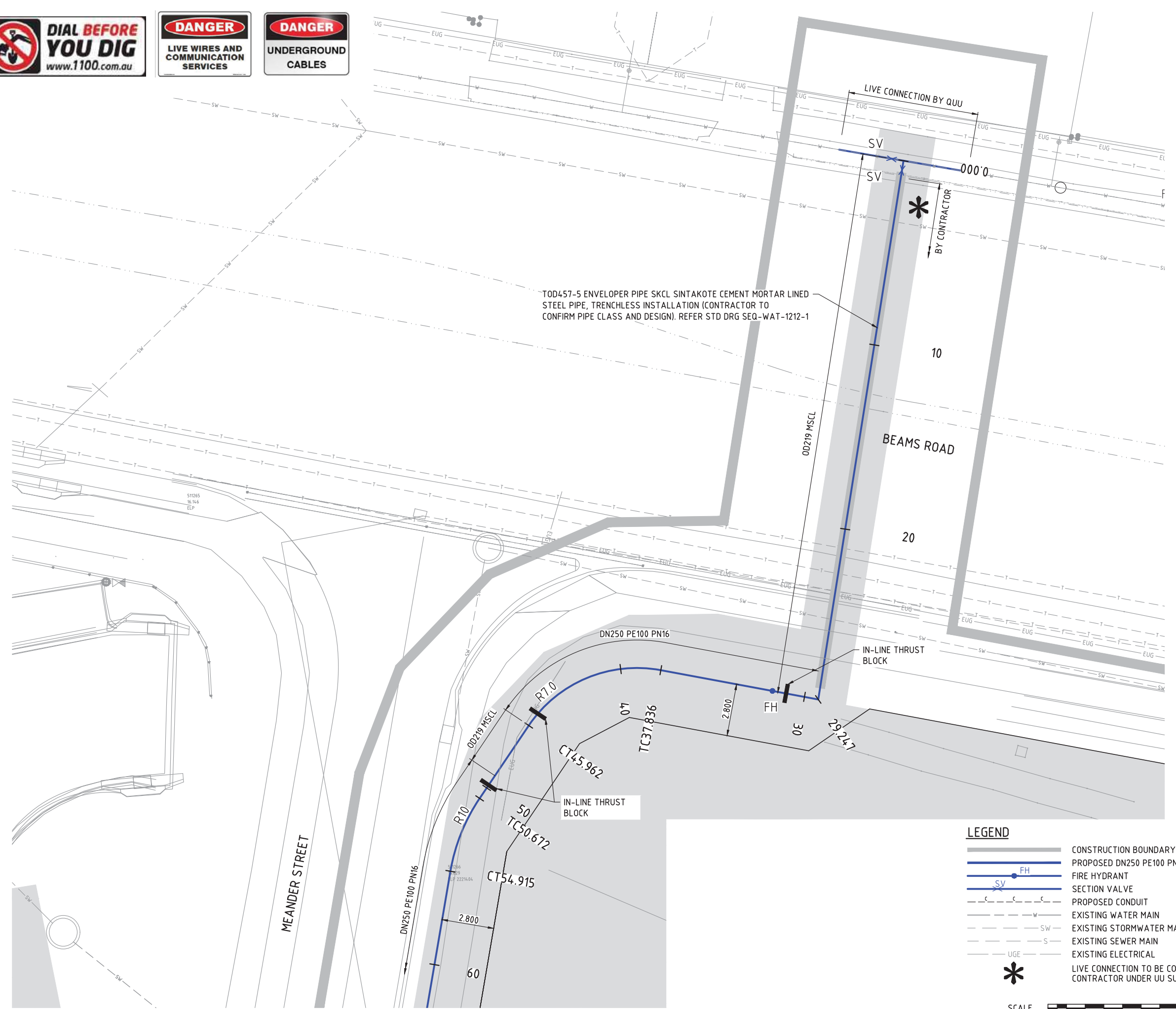

**LEGEND**

- CONSTRUCTION BOUNDARY
- PROPOSED DN250 PE100 PN16 WATER MAIN
- FIRE HYDRANT
- SECTION VALVE
- PROPOSED CONDUIT
- EXISTING WATER MAIN
- EXISTING STORMWATER MAIN
- EXISTING SEWER MAIN
- EXISTING ELECTRICAL
- LIVE CONNECTION TO BE COMPLETED BY CONTRACTOR UNDER UU SUPERVISION

**SCALE**

1: 100 (A1 UNREDUCED)

**WATER RETICULATION LAYOUT PLAN**  
SCALE 1:100

M:\2021\2121 Carseldine Village Stage V\Engineering\ACAD\21-121-61-WATER.dwg Plotted by: RW on 21/11/2023 8:35:35 AM

DO NOT SCALE THIS DRAWING  
IF IN DOUBT - ASK!

LOCALITY PLAN

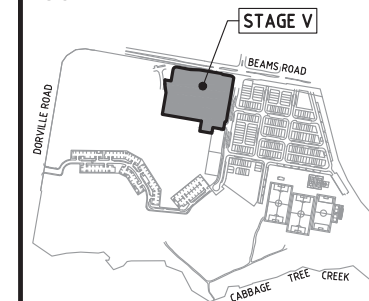

REVISIONS

| No | Description      | Date       | By |
|----|------------------|------------|----|
| A  | FOR APPROVAL     | 12.10.2023 | RW |
| B  | QUU RFI REVISION | 24.11.2023 | RW |

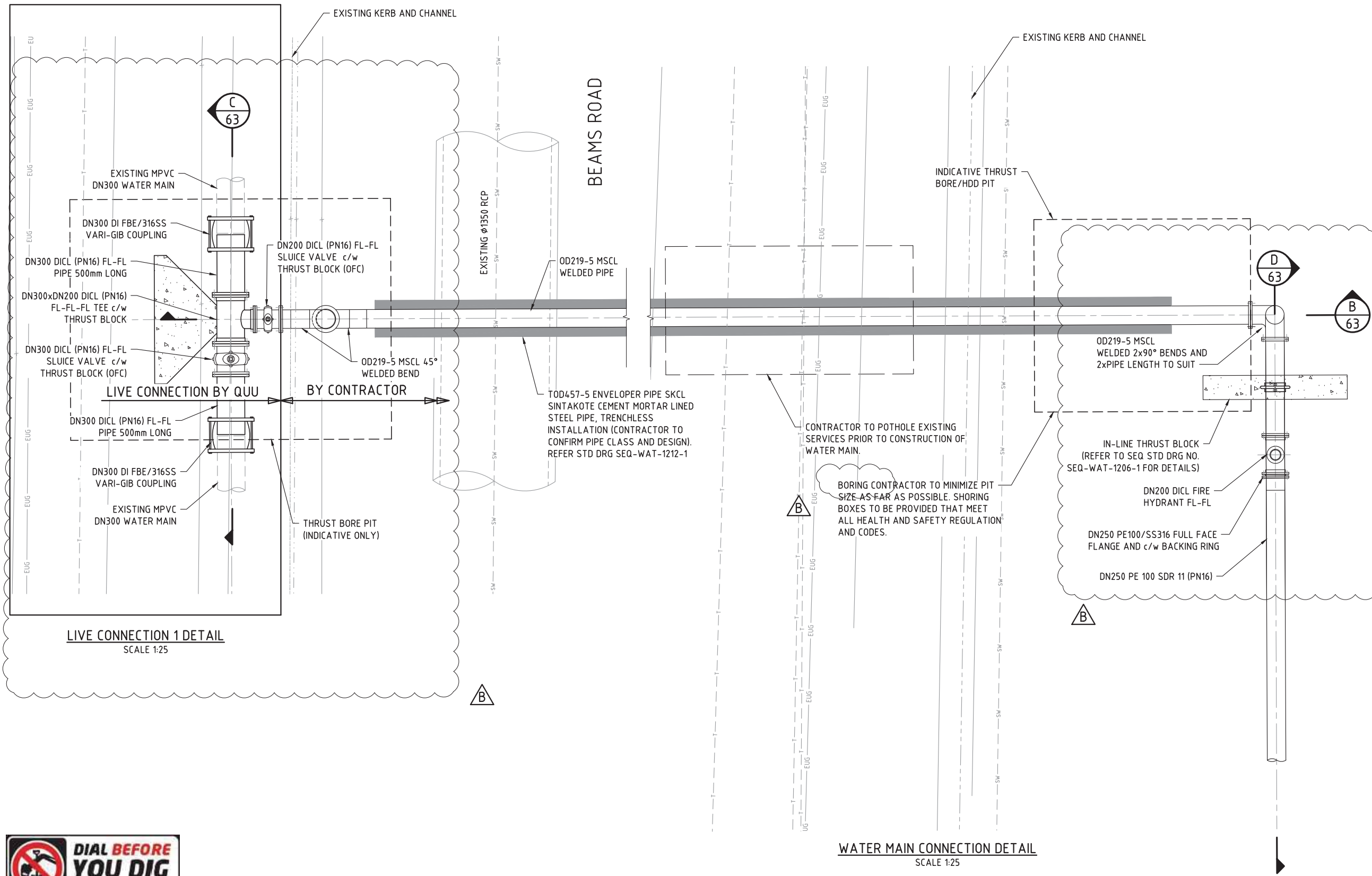

Client  
**ECONOMIC DEVELOPMENT QUEENSLAND (EDQ)**

Project  
**CARSELDINE VILLAGE STAGE V**



Approved  
*M. Shaw* Digitally signed by Mark Shaw RPEQ 17544 Date: 2023.11.21 10:54:22+1000'

Drawing Title  
**WATER RETICULATION WATER MAIN CONNECTION DETAILS SHEET 1**

|                   |                         |               |                   |
|-------------------|-------------------------|---------------|-------------------|
| Drawn<br>RW       | Designed<br>JB          | Checked<br>MS | Date<br>OCT '23   |
| Scale<br>AS SHOWN | Drawing No<br>21-121-62 |               | Sheet<br>62 of 20 |
| A1                | Revision<br>B           |               |                   |

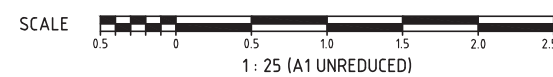

M:\2021\2121 Careldine Village Stage V\Engineering\ACAD\21-121-62-WATER.dwg Plotted by: RW on 21/11/2023 8:35:42 AM

DO NOT SCALE THIS DRAWING IF IN DOUBT - ASK!

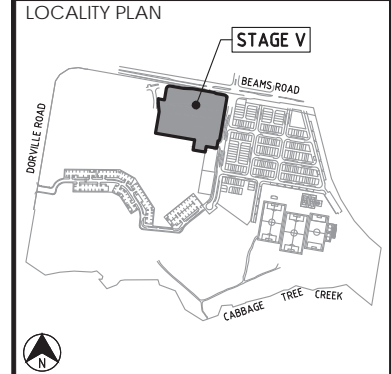

REVISIONS

| No | Description  | Date       | By |
|----|--------------|------------|----|
| A  | FOR APPROVAL | 12.10.2023 | RW |
|    |              |            |    |
|    |              |            |    |
|    |              |            |    |
|    |              |            |    |
|    |              |            |    |
|    |              |            |    |
|    |              |            |    |
|    |              |            |    |
|    |              |            |    |
|    |              |            |    |
|    |              |            |    |
|    |              |            |    |
|    |              |            |    |
|    |              |            |    |
|    |              |            |    |
|    |              |            |    |
|    |              |            |    |
|    |              |            |    |
|    |              |            |    |
|    |              |            |    |
|    |              |            |    |
|    |              |            |    |
|    |              |            |    |
|    |              |            |    |

Client  
ECONOMIC DEVELOPMENT QUEENSLAND (EDQ)

Project  
CARSELDINE VILLAGE STAGE V



Approved  
*M. Shaw*  
Digitally signed by Mark Shaw RPEQ 17544 Date: 2023.11.21 10:54:22+1000'

Drawing Title  
**WATER RETICULATION WATER MAIN CONNECTION DETAILS SHEET 2**

|                   |                         |                   |                 |
|-------------------|-------------------------|-------------------|-----------------|
| Drawn<br>RW       | Designed<br>JB          | Checked<br>MS     | Date<br>OCT '23 |
| Scale<br>AS SHOWN |                         | Sheet<br>63 of 20 |                 |
| A1                | Drawing No<br>21-121-63 | Revision<br>A     |                 |

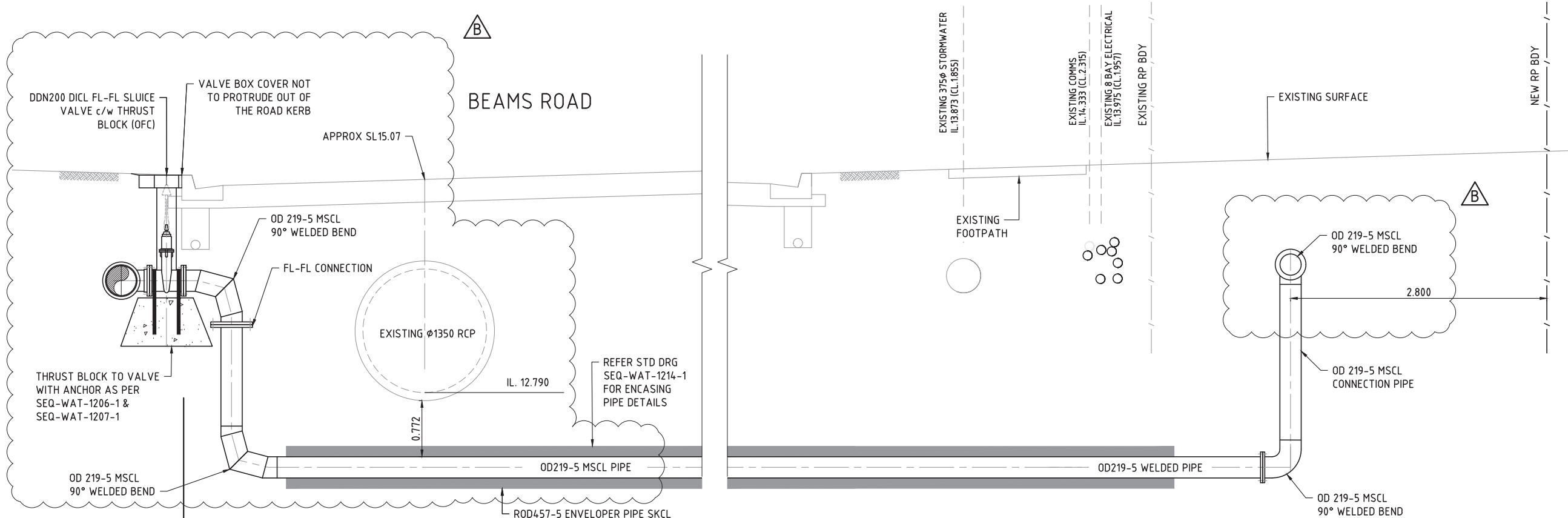

**B** SECTION 62 SCALE 1:25

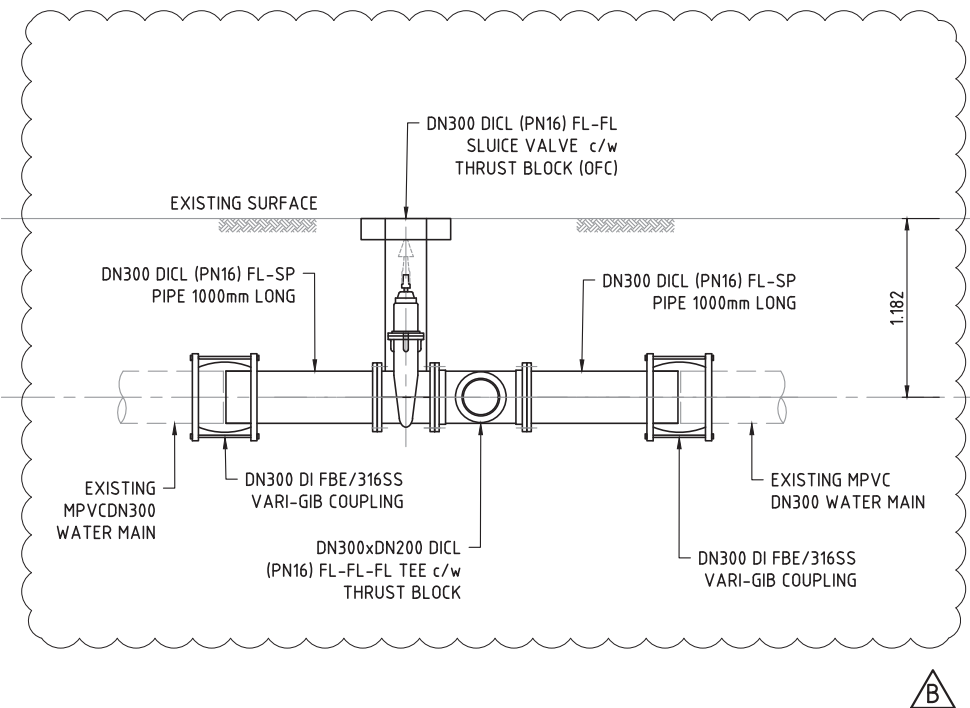

**C** SECTION - LIVE CONNECTION 1 62 SCALE 1:25

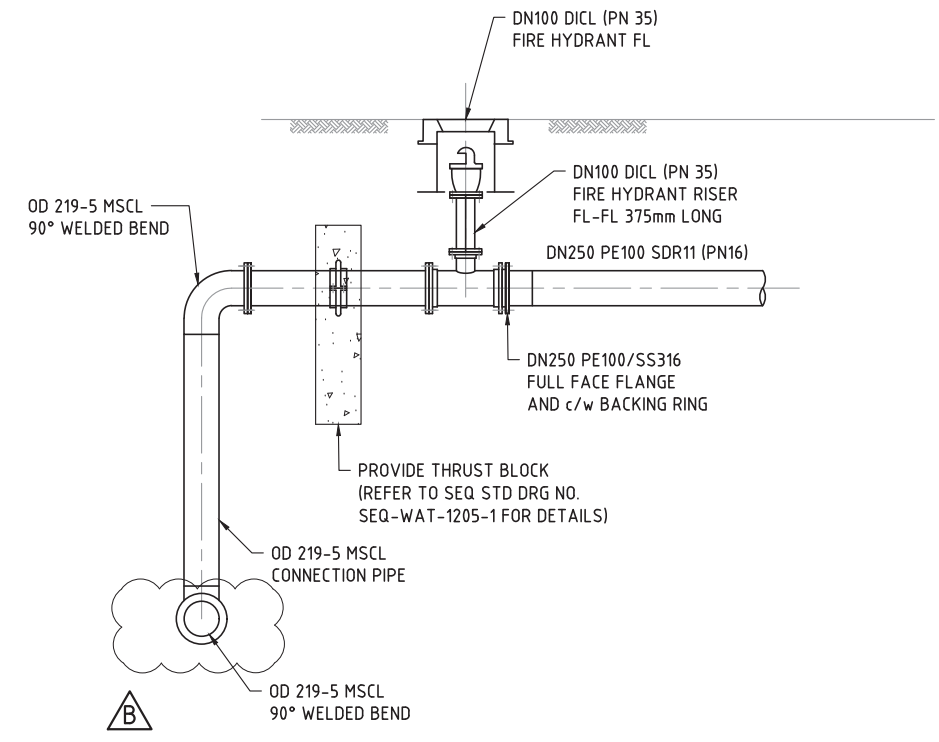

**D** SECTION 62 SCALE 1:25



M:\2021\2121 Carseldine Village Stage V\Engineering\ACAD\21-121-63-WATER.dwg Plotted by: RW on 21/11/2023 @ 8:35:55 AM

NON-CONFORMANCE TABLE

| No.  | SEQ CODE CLAUSE  | DETAILS FOR PROPOSED VARIATION   | REASON FOR PROPOSED VARIATION  | RELEVANT SERVICE |
|------|--|--|--|------------------|
| NC01 | SEQ WATER SUPPLY CODE CI 5.12.5.2 CLEARANCE REQUIREMENTS | WATER MAIN TO BE CONSTRUCTED WITH A CRANK OVER EXISTING ELECTRICAL RESULTING IN A CLEARANCE OF 0.15m INSTEAD OF MIN 0.5m   | CONSTRUCTION OF WATER MAIN UNDER EXISTING ELECTRICAL WOULD RESULT IN A DEEP TRENCH WITH ELECTRICAL CONDUIT HANGING ACROSS IT AND AS SUCH BE A SAFETY RISK. | DRINKING WATER   |
| NC02 | SEQ WATER SUPPLY CODE CI 7.4.2 PIPE COVERS               | WATER MAIN TO BE CONSTRUCTED WITH A CRANK OVER EXISTING ELECTRICAL RESULTING IN REDUCED COVER OF 0.45m INSTEAD OF MIN 0.6m | CONSTRUCTION OF WATER MAIN UNDER EXISTING ELECTRICAL WOULD RESULT IN A DEEP TRENCH WITH ELECTRICAL CONDUIT HANGING ACROSS IT AND AS SUCH BE A SAFETY RISK. | DRINKING WATER   |

DO NOT SCALE THIS DRAWING  
IF IN DOUBT - ASK!



LOCALITY PLAN

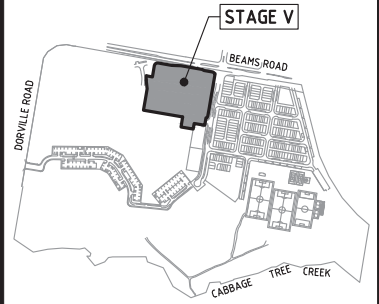

REVISIONS

| No | Description  | Date       | By |
|----|--------------|------------|----|
| A  | FOR APPROVAL | 12.10.2023 | VS |
|    |              |            |    |
|    |              |            |    |
|    |              |            |    |
|    |              |            |    |
|    |              |            |    |
|    |              |            |    |
|    |              |            |    |
|    |              |            |    |
|    |              |            |    |
|    |              |            |    |
|    |              |            |    |
|    |              |            |    |
|    |              |            |    |
|    |              |            |    |
|    |              |            |    |
|    |              |            |    |
|    |              |            |    |
|    |              |            |    |
|    |              |            |    |
|    |              |            |    |

Client  
**ECONOMIC DEVELOPMENT QUEENSLAND (EDQ)**

Project  
**CARSELDINE VILLAGE STAGE V**



Approved  
*M. Shaw* Digitally signed by Mark Shaw RPEQ 17544 Date: 2023.11.21 10:54:23+1000'

Drawing title  
**WATER MAIN CONNECTION NON-CONFORMANCE TABLE**

|          |                      |            |              |
|----------|----------------------|------------|--------------|
| Drawn VS | Designed VS          | Checked MS | Date OCT '23 |
| Scale    |                      |            | Sheet 64 of  |
| A1       | Drawing No 21-121-64 | Revision A |              |

M:\2021\2121 Carældine Village Stage V\Engineering\ACAD\21-121-64-WATER.dwg Plotted by: RW on 21/11/2023 9:35:56 AM

# TECHNICAL MEMORANDUM

---

PLANS AND DOCUMENTS  
referred to in the PDA  
DEVELOPMENT APPROVAL



Approval no: DEV2019/1074  
Date: 26 March 2020

**To:** Richard Bender - EDQ  
**From:** Ralph Williams - DesignFlow  
**Reviewed:** Shaun Leinster (RPEQ15637) - DesignFlow  
**Date:** 10 October 2019  
**Subject:** Carseldine Urban Village – Local flood assessment to support Stage 1 development

**Attachments**

1. Peak flood depths – Existing case - 50%, 5%, 1% AEP event
2. Peak flood depths – Proposed case 50%, 5%, 1% AEP
3. Peak flood level impacts – 50%, 5%, 1% AEP

---

## 1 INTRODUCTION

This technical memorandum provides a summary of local flood assessments for the Carseldine Urban Village to support Stage 1 development. This modelling captures in detail the potential local flood impacts and potential drainage upgrades at the following locations:

- Beams Road;
- Railway at the eastern boundary of the site; and
- Local drainage to Cabbage Tree Creek

The outcomes of this assessment provide minimum drainage requirements associated with Stage 1 development to manage local flood impacts. Outcomes from this assessment are to inform the detail design of the Stage 1.

When reading this technical memorandum reference should be made to *Carseldine Urban Village – Updated Stormwater Management Plan* (DesignFlow report Version 3 2019). Figure 1 shows the current masterplan for the development from which this assessment has been based, including the Stage 1 development boundary.

## 2 BACKGROUND

The regional flood assessment of the Carseldine Urban Village development has been completed, as outlined in *Carseldine Urban Village – Updated Stormwater Management Plan* (DesignFlow report Version 3 2019), based on Brisbane City Council (BCC) supplied URBS and TUFLOW regional flood models for Cabbage Tree Creek. These models were updated as necessary to make suitable for regional flood impact assessment of the Carseldine Urban Village development.

The Cabbage Tree Creek modelling is at a regional scale and not suitable for a detailed assessment of the various local catchments that influence the site. Therefore, a separate local scale flood modelling exercise has been completed to capture potential flood impacts associated with the development, including local impacts at Beams Road and the railway at the eastern boundary of the site. Additional drainage survey was completed at the northern boundary of the site along Beams Rd and within the site to inform this local flood modelling.

This technical memorandum provides a summary of the local flood modelling.



# TECHNICAL MEMORANDUM



Figure 1 – Carseldine Urban Village masterplan (source: RPS)

# TECHNICAL MEMORANDUM

## 3 EXISTING CASE MODELLING

Local modelling has been carried out using a WBNM rainfall runoff model that feeds local catchment hydrographs into a 1D/2D TUFLOW hydraulic model. The existing case WBNM model sub-catchments are shown on Figure 2 which also indicates the general direction of overland flow (yellow arrows). Figure 2 also shows the existing pipe drainage network as modelled in TUFLOW for this investigation (aqua/black lines). It is noted that in some areas these drainage lines have been laid against the natural fall of the land and therefore their alignment does not necessarily match that of the overland flow as represented by the yellow arrows. Sub-catchment details are provided on Table 1.

A summary of the existing site drainage characteristics is as follows:

- The existing Beams Rd catchments flow to the east and north away from the site.
- Catchment B1 drains to the West Outfall Pipe to Cabbage Tree Creek (refer Figure 2). When this pipe is at capacity, runoff flows eastwards through the site.
- The majority of the proposed development area currently drains to the East Outfall Pipe to Cabbage Tree Creek (refer Figure 2). When this pipe is at capacity, site runoff will generally collect over the low-lying areas around the playing fields. Runoff will then drain southwards via the open drain adjacent to the railway. Modelling also predicts that during large events, overland flow from the site heads north and east toward the railway and Beams Rd.
- The Cabbage Tree Creek outfall pipes are predicted to flow in reverse direction when Cabbage Tree Creek flood levels are high.



Figure 2 - Existing case WBNM sub-catchments

Table 1 - Existing case WBNM sub-catchment details

| WBNM ID | Area (ha) | Fraction Impervious (%) | Downstream ID |
|---------|-----------|-------------------------|---------------|
| A1      | 10.546    | 59.64                   | A3            |
| A2      | 4.582     | 65.43                   | A3            |
| A3      | 3.424     | 28.42                   | A4            |
| A4      | 0.902     | 45.53                   | A5            |
| A5      | 0.799     | 49.91                   | A6            |
| A6      | 2.738     | 83.29                   | A7            |
| A7      | 13.295    | 52.13                   | SINK          |
| B1      | 10.021    | 9.47                    | B2            |
| B2      | 3.177     | 18.72                   | B3            |
| B3      | 5.454     | 5.56                    | B6            |
| B4A     | 1.291     | 84.66                   | B4B           |
| B4B     | 1.054     | 20.26                   | B4C           |
| B4C     | 2.282     | 12.26                   | B5            |
| B5      | 2.514     | 0.00                    | B7            |
| B6      | 1.746     | 0.00                    | B7            |
| B7      | 3.345     | 4.20                    | B8            |
| B8      | 5.174     | 3.63                    | SINK          |

The WBNM model has been run using ARR2016 ensemble patterns with burst durations ranging from 5 minutes to 6 hours. The results of the WBNM model have then been used to select ensemble patterns with a central tendency for the following durations that have then been run in the TUFLOW model; 15min, 30min, 45min, 60min, 120min and 180min. These durations were selected based on a review of critical durations across the local catchment study area. Modelling has been carried out for the 1%, 5% and 50% AEP events.

A WBNM lag parameter of 1.4 has been selected based on a Rational Method validation of peak flows at WBNM ID B8 (refer Validation Section for details).

Rainfall intensities and loss rates are based on values from the ARR 2016 data hub. Rainfall intensities relevant to the Carseldine site for varying AEP and storm durations are provided in Table 2.

Table 2 – Rainfall intensities (mm/hr) - Carseldine

| Duration | AEP    |        |        |        |        |        |        |
|----------|--------|--------|--------|--------|--------|--------|--------|
|          | 63.20% | 50%    | 20%    | 10%    | 5%     | 2%     | 1%     |
| 5 min    | 115.20 | 129.60 | 176.40 | 207.60 | 237.60 | 278.40 | 309.60 |
| 10 min   | 94.20  | 106.20 | 144.00 | 169.20 | 193.20 | 225.00 | 248.40 |
| 15 min   | 80.00  | 90.40  | 122.00 | 143.20 | 163.60 | 190.40 | 210.40 |
| 20 min   | 69.60  | 78.60  | 106.50 | 124.80 | 142.80 | 166.20 | 183.90 |
| 25 min   | 61.92  | 69.84  | 94.56  | 111.12 | 127.20 | 148.32 | 164.16 |
| 30 min   | 55.80  | 63.00  | 85.40  | 100.40 | 115.00 | 134.40 | 149.00 |
| 45 min   | 43.60  | 49.20  | 66.80  | 78.80  | 90.67  | 106.27 | 118.40 |
| 1 hour   | 36.10  | 40.80  | 55.60  | 65.70  | 75.70  | 89.10  | 99.60  |
| 1.5 hour | 27.40  | 31.00  | 42.40  | 50.33  | 58.27  | 68.67  | 77.33  |
| 2 hour   | 22.45  | 25.40  | 34.90  | 41.55  | 48.20  | 57.50  | 64.50  |
| 3 hour   | 16.90  | 19.17  | 26.50  | 31.70  | 37.00  | 44.33  | 50.00  |
| 4.5 hour | 12.78  | 14.51  | 20.24  | 24.22  | 28.44  | 34.22  | 38.89  |
| 6 hour   | 10.50  | 11.97  | 16.83  | 20.33  | 23.83  | 28.67  | 32.67  |
| 9 hour   | 8.02   | 9.18   | 13.00  | 15.78  | 18.67  | 22.56  | 25.67  |
| 12 hour  | 6.65   | 7.64   | 10.92  | 13.25  | 15.75  | 19.08  | 21.83  |
| 18 hour  | 5.12   | 5.94   | 8.56   | 10.50  | 12.44  | 15.22  | 17.44  |
| 24 hour  | 4.25   | 4.96   | 7.21   | 8.88   | 10.58  | 12.96  | 14.92  |
| 30 hour  | 3.70   | 4.30   | 6.33   | 7.80   | 9.30   | 11.43  | 13.20  |
| 36 hour  | 3.28   | 3.83   | 5.67   | 6.97   | 8.36   | 10.31  | 11.92  |
| 48 hour  | 2.71   | 3.17   | 4.73   | 5.85   | 7.02   | 8.69   | 10.08  |
| 72 hour  | 2.03   | 2.39   | 3.58   | 4.47   | 5.38   | 6.69   | 7.81   |

An initial loss/continuing loss approach is adopted. Initial and continuing losses for impervious areas are taken at 0mm/hr, whilst continuing losses for pervious areas are taken at 2.2mm/hr. Initial losses for pervious areas vary depending on the AEP and the storm duration. These are listed in Table 3.

Table 3 Pervious area initial loss (mm) modelled

| Duration  | 50% AEP | 20% AEP | 10% AEP | 5% AEP | 2% AEP | 1% AEP |
|-----------|---------|---------|---------|--------|--------|--------|
| 10 min    | 10.4    | 7.6     | 5.8     | 4.1    | 2.9    | 2.1    |
| 15 min    | 10.4    | 7.6     | 5.8     | 4.1    | 2.9    | 2.1    |
| 20 min    | 10.4    | 7.6     | 5.8     | 4.1    | 2.9    | 2.1    |
| 25 min    | 10.4    | 7.6     | 5.8     | 4.1    | 2.9    | 2.1    |
| 30 min    | 10.4    | 7.6     | 5.8     | 4.1    | 2.9    | 2.1    |
| 45 min    | 10.4    | 7.6     | 5.8     | 4.1    | 2.9    | 2.1    |
| 1 hour    | 10.4    | 7.6     | 5.8     | 4.1    | 2.9    | 2.1    |
| 1.50 hour | 11.1    | 3.2     | 0       | 0      | 0      | 3.2    |
| 2 hours   | 11.9    | 3.7     | 0       | 0      | 0      | 0      |
| 3 hours   | 8.9     | 0       | 0       | 0      | 0      | 0      |
| 6 hours   | 5.9     | 0       | 0       | 0      | 0      | 0      |
| 12 hours  | 8.3     | 0       | 0       | 0      | 0      | 0      |
| 18 hours  | 7.7     | 0       | 0       | 0      | 0      | 0      |
| 24 hours  | 6.3     | 2.9     | 0.6     | 0      | 0      | 0      |
| 36 hours  | 13      | 8       | 4.7     | 1.6    | 0      | 0      |
| 48 hours  | 13      | 9.5     | 7.2     | 5      | 0      | 0      |
| 72 hours  | 13      | 12.3    | 11.8    | 11.4   | 3.3    | 0      |

Local catchment inflow hydrographs from the existing case WBNM model have been input to the existing case TUFLOW model. The existing case TUFLOW model layout is shown on Figure 3 and details are summarised below:

- TUFLOW HPC Build 2018-03-AB\_64\_iSP.
- Model grid size of 1m to provide detail resolution of potential flood impacts
- Run for 1%, 5% and 50% AEP events for ensemble temporal patterns with a central tendency for the events durations ranging from 15 minutes to 3 hours.
- WBNM local catchment inflow hydrographs are input to TUFLOW using TUFLOW's 2d\_sa polygon approach.
- Topography based on aerial LiDAR survey and defined using a TUFLOW 1m grid.
- Manning's 'n' values of; Road – 0.02, Urban Lots – 0.18, Vegetated Area – 0.075, Cleared Open space – 0.03
- Existing on-site pipe drainage associated with the two existing outfalls to Cabbage Tree Creek have been incorporated using 1D pipe elements. Details are based on a recent survey completed by Land Partners (June, 2019). In addition to survey of the main site drainage lines, additional pipe network data has been sourced from BCC records. The existing drainage pipes included in the existing case TUFLOW modelling are shown on Figure 4. Pipe diameters shown in metres.
- Cabbage Tree Creek upstream boundary is a Q5 flow rate extracted from the Cabbage Tree Creek regional model. The Cabbage Tree Creek downstream boundary is a Q5 water level. The remaining two external boundary conditions are normal depth rating curves calculated by TUFLOW based on a slope of 1%. Note: a Q5 boundary condition is in accordance with standard modelling procedures for coincident regional flood events for local modelling. The ratio of local to regional catchment associated with the Carseldine Urban Village is 0.018.

Peak depth maps for the Existing Case modelling are provided in Attachment 1.

# TECHNICAL MEMORANDUM

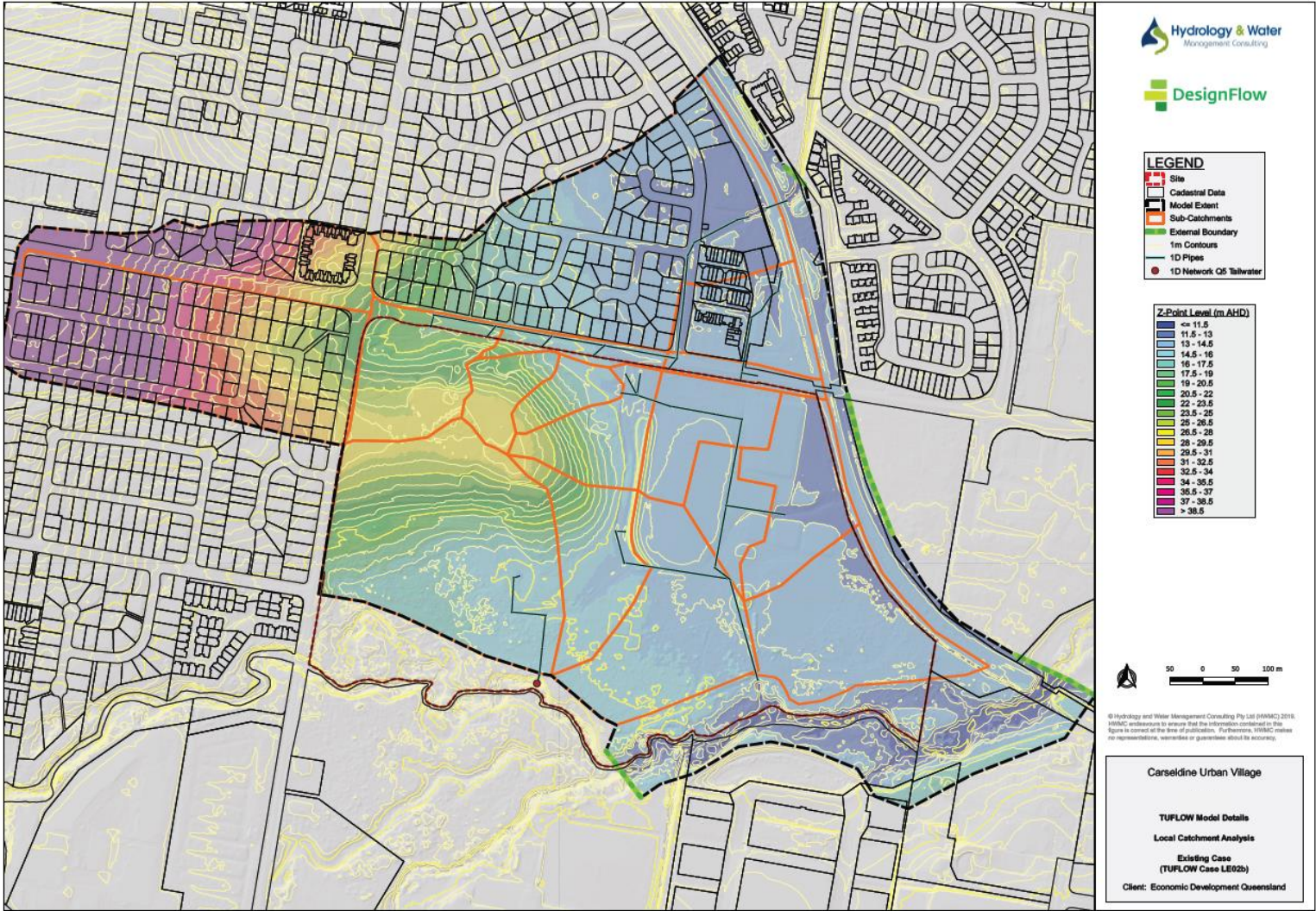

Figure 3 Existing case TUFLOW model layout

## TECHNICAL MEMORANDUM

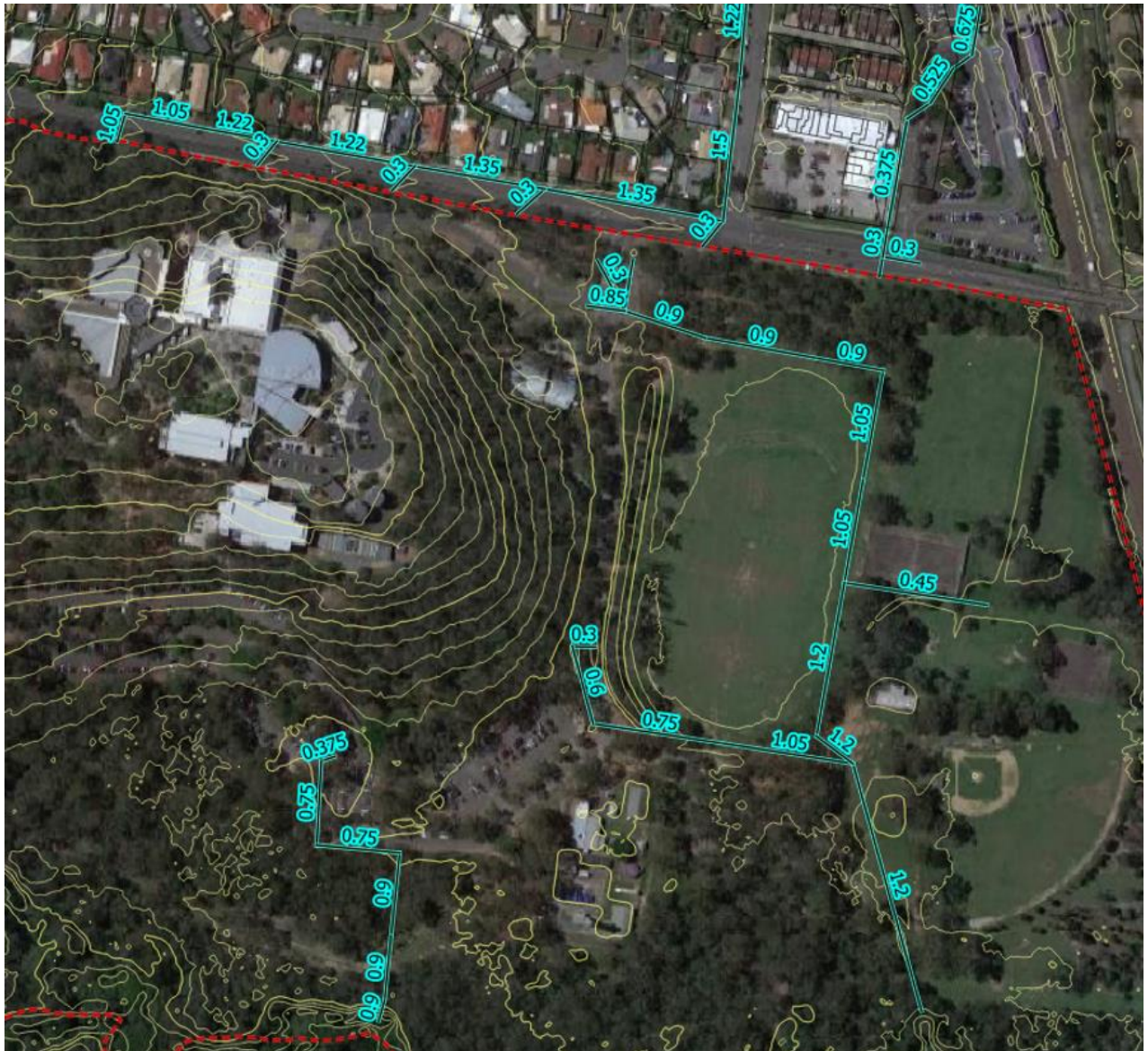

Figure 4 - Existing case pipe drainage and diameters (m)

### 4 VALIDATION

It is not possible to validate peak flows or levels in the hydraulic model because of storage effects and breakout flows from the defined hydrologic flow paths. Instead, a Rational Method peak flow validation has been carried out based on the existing case WBNM peak flows at the local catchment outlet near Cabbage Tree Creek (WBNM ID B8).

The 1% AEP Rational Method peak flow calculated at the outlet of B8 is 10.4 m<sup>3</sup>/s. This is based on a Tc of 43 minutes, a catchment area of 36.1 Ha and a C10 value of 0.71. The peak flow predicted by the WBNM model at this location is 10.5 m<sup>3</sup>/s which compares well.

## 5 DEVELOPED CASE MODELLING

The WBNM sub-catchments were updated to reflect the proposed development. For the purpose of this assessment to inform Stage 1 development, the ultimate site development has been applied to the hydrology model (refer to Figure 1 – Carseldine Urban Village Masterplan). All development areas have been assigned a Fraction Impervious of 90%. The proposed case WBNM sub-catchments are shown on Figure 5 and details are provided in Table 4.



Figure 5 - Proposed case WBNM sub-catchments



Table 4 - Developed case WBNM sub-catchment details

| WBNM ID | Area (ha) | Fraction Impervious (%) |
|---------|-----------|-------------------------|
| A1      | 10.546    | 59.64                   |
| A2      | 4.582     | 65.43                   |
| A3      | 3.424     | 28.40                   |
| A4      | 0.958     | 57.19                   |
| A5      | 0.799     | 49.89                   |
| A6      | 2.738     | 83.29                   |
| A7      | 13.295    | 52.13                   |
| B1      | 10.021    | 9.48                    |
| B2      | 2.952     | 22.21                   |
| B3      | 3.504     | 8.63                    |
| B4A     | 1.481     | 89.20                   |
| B4B     | 3.679     | 75.04                   |
| B4C     | 0.452     | 88.32                   |
| B5      | 2.099     | 89.93                   |
| B6      | 1.235     | 84.88                   |
| B6      | 1.014     | 90.00                   |
| B7      | 2.545     | 83.70                   |
| B7A     | 3.528     | 22.59                   |
| B8      | 2.567     | 5.20                    |
| B8A     | 0.927     | 31.15                   |

The developed case TUFLOW model is shown on Figure 6. It is equivalent to that of the existing case except for the following changes that have been made to represent the development site:

- Run with developed case WBNM hydrology
- Latest earthworks design tin by Calibre has been incorporated into the model topography (June 2019) – note bioretention extended detention depth is excluded from the flood storage
- Overland flow paths through the site have a Manning's 'n' value of 0.075 (medium vegetation).
- A bund with a crest a RL 13.7 has been applied across the south eastern outlet drain. This crest level ties in approximately with the natural ground level at this location. A one-way flapped 1200mm dia RCP has been placed through this bund.

**Note:** this outlet arrangement has been designed to allow development flows to discharge to Cabbage Tree Creek, but prevent Cabbage Tree Creek flows from backing up northwards through this drain and into the development zone. Inclusion of the one-way flap valve was deemed necessary based on scenario testing of frequent local storm events, coupled with a relatively high

creek water level in Cabbage Tree Creek, which may cause local flooding (e.g. a 2 year local event with a 5 year tailwater level in Cabbage Tree Creek).

- Diversion of runoff from the north west of the site (CatB4A) via the new drainage network that discharges flows to Cabbage Tree Creek – this diversion manages development flows as well as existing drainage that reports to the Stage 1 western entry road from beams road (CatB4A). This diversion is designed to avoid flood impacts at Beams Road.
- Drainage of flows from the new eastern access road along Beams Rd (Cat B4C) to the existing Beams Rd drainage network via 450mm RCP
- Drainage sump at the low point just south of Stage 1 Lot 3
- Duplication of the existing 1200mm dia outfall to Cabbage Tree Creek

Peak depth maps for the Developed Case modelling are provided in Attachment 2.

# TECHNICAL MEMORANDUM



Figure 6 TUFLOW developed case model setup

## TECHNICAL MEMORANDUM

### 6 IMPACT ASSESSMENT

Peak flood level impact maps are provided in Attachment 3. In summary the following is noted:

- Flood level reductions are predicted at Beams Rd and areas to the north for all events modelled.
- Flood level reductions are predicted along the rail corridor for all events modelled.

**Note:** Impacts shown within Cabbage Tree Creek are not realistic and should be dismissed because Cabbage Tree Creek has been run in steady state for the purpose of assigning a tailwater level of the local catchment analysis. Therefore, catchment timing effects are not properly considered in the local hydraulic model. The separate Cabbage Tree Creek regional flood analysis (refer to Carseldine Urban Village Updated Stormwater Management plan (DesignFlow Version 3 2019) has demonstrated that the increased runoff from the proposed development site is not expected to coincide with peak flows in the creek and that no adverse impacts are predicted.

### 7 RECOMMENDATIONS







Based on the local flood modelling results for the Carseldine Urban Village the following is recommended to be implemented as part of Stage 1 works:

- All flows associated with the Stage 1 north western entry road are diverted south to discharge to Cabbage Tree Creek. This includes the existing catchment to the west of this entry road (CatB4A – refer to Figure 5), where 1% AEP flows of up to 1.4m<sup>3</sup>/s are to be captured and directed southward.
- Existing drainage pipes impacted by the development are connected to the new drainage and adequately allowed for in the drainage design based on the general drainage assumptions outlined in this document.
- The minor catchment draining to the new eastern Stage 1 entry road off Beams Rd (CatB4C – refer to Figure 5) can be connected to the existing Beams Road drainage network to the north (450mm dia pipe connection). This should only occur after the drainage at the western entrance road is constructed to avoid an impact on the Beams Rd drainage.
- Ensure Stage 1 flows (except for the eastern entry road as mentioned above) are discharged to Cabbage Tree Creek. The drainage system must have capacity to discharge development flows as well as existing discharges that are connected to the Stage 1 drainage.
- Include a drainage pit that connects to the new drainage for Stage 1 in the low lying area south of Stage 1 lot 3 to manage flooding in this low lying zone.
- Final development fill levels and finished floor levels should be based on whatever is the highest flood level from the following:
  - Cabbage Tree Creek regional flooding (refer to the *Carseldine Urban Village – Updated Stormwater Management Plan*, DesignFlow 2019)
  - Local catchment flooding (this assessment)
  - Internal road drainage (future detail design)









ATTACHMENT 1 – PEAK FLOOD DEPTHS – EXISTING CASE

---

**LEGEND**

-  Site
-  Cadastral Data
-  Model Extent
-  External Boundary
-  1D Pipes - Existing
-  1m Contour (LiDAR)

**Depth (m)**

-  <= 0.2
-  0.2 - 0.5
-  0.5 - 0.75
-  0.75 - 1
-  1 - 1.25
-  1.25 - 1.5
-  1.5 - 1.75
-  1.75 - 2
-  > 2

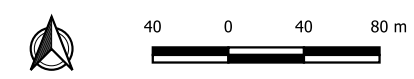

© Hydrology and Water Management Consulting Pty Ltd (HWMC) 2019.  
HWMC endeavours to ensure that the information contained in this figure is correct at the time of publication. Furthermore, HWMC makes no representations, warranties or guarantees about its accuracy.

**Carseldine Urban Village**

**Peak Flood Depths  
Local Catchment Analysis**





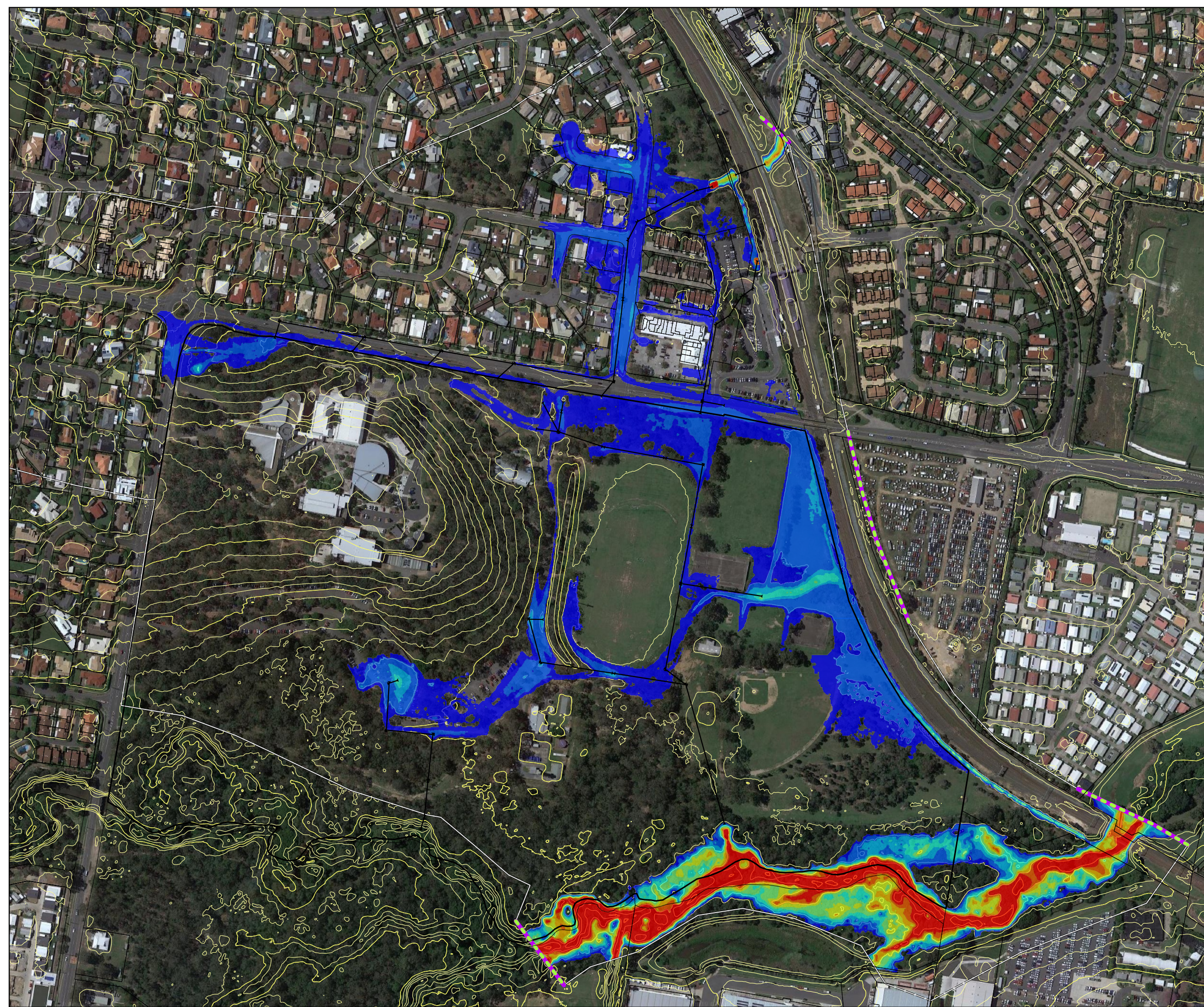

**Existing Case  
(TUFLOW Case LE02c)**

**50% AEP Event**









Client: Economic Development Queensland



**LEGEND**

-  Site
-  Cadastral Data
-  Model Extent
-  External Boundary
-  1D Pipes - Existing
-  1m Contour (LiDAR)

**Depth (m)**

-  ≤ 0.2
-  0.2 - 0.5
-  0.5 - 0.75
-  0.75 - 1
-  1 - 1.25
-  1.25 - 1.5
-  1.5 - 1.75
-  1.75 - 2
-  > 2

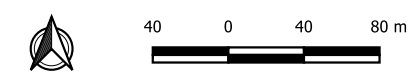

© Hydrology and Water Management Consulting Pty Ltd (HWMC) 2019.  
HWMC endeavours to ensure that the information contained in this figure is correct at the time of publication. Furthermore, HWMC makes no representations, warranties or guarantees about its accuracy.

**Carseldine Urban Village**

**Peak Flood Depths  
Local Catchment Analysis**





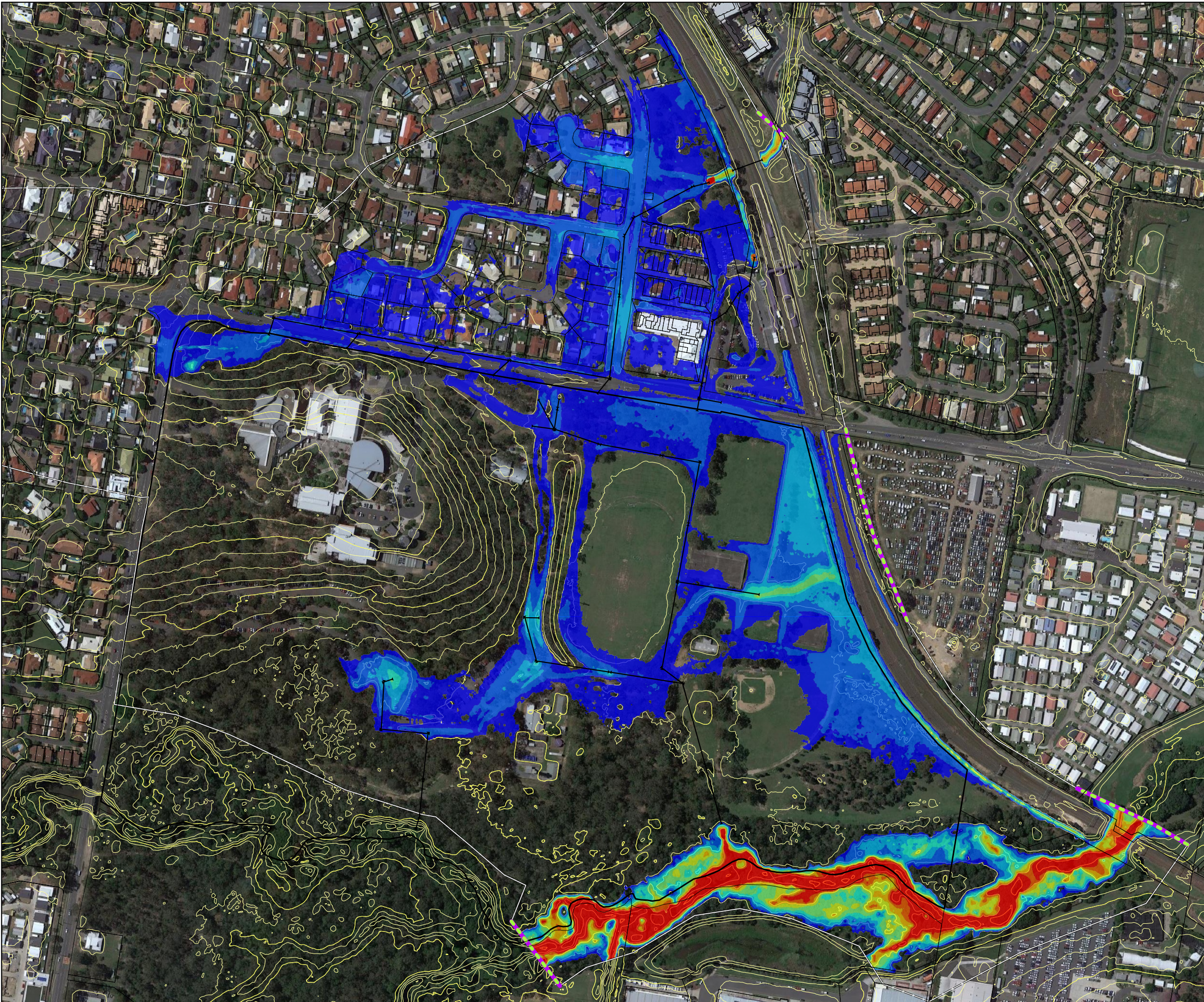

Existing Case  
(TUFLOW Case LE02b)

5% AEP Event









Client: Economic Development Queensland



**LEGEND**

-  Site
-  Cadastral Data
-  Model Extent
-  External Boundary
-  1D Pipes - Existing
-  1m Contour (LiDAR)

**Depth (m)**

-  ≤ 0.2
-  0.2 - 0.5
-  0.5 - 0.75
-  0.75 - 1
-  1 - 1.25
-  1.25 - 1.5
-  1.5 - 1.75
-  1.75 - 2
-  > 2



© Hydrology and Water Management Consulting Pty Ltd (HWMC) 2019.  
HWMC endeavours to ensure that the information contained in this figure is correct at the time of publication. Furthermore, HWMC makes no representations, warranties or guarantees about its accuracy.

**Carseldine Urban Village**

**Peak Flood Depths  
Local Catchment Analysis**

**Existing Case  
(TUFLOW Case LE02b)**

**1% AEP Event**

Client: Economic Development Queensland

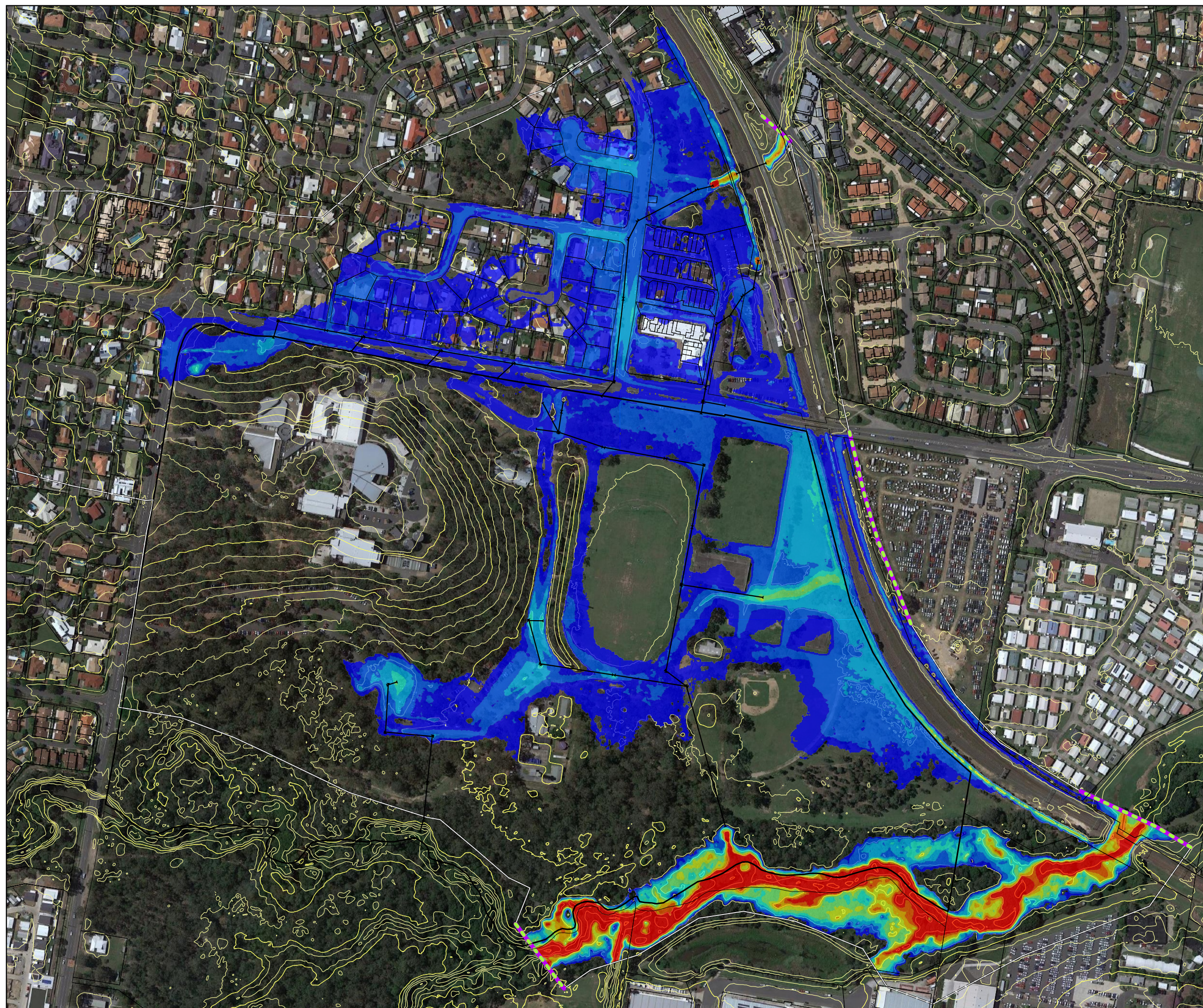



















ATTACHMENT 2 – PEAK FLOOD DEPTHS – PROPOSED CASE

---

**LEGEND**

-  Site
-  Cadastral Data
-  Model Extent
-  External Boundary
-  Design Contours (0.1m)
-  Proposed Case Z-Point Modifiers
-  1D Pipes - Existing
-  1D Pipes - Proposed

**Depth (m)**

-  <= 0.2
-  0.2 - 0.5
-  0.5 - 0.75
-  0.75 - 1
-  1 - 1.25
-  1.25 - 1.5
-  1.5 - 1.75
-  1.75 - 2
-  > 2

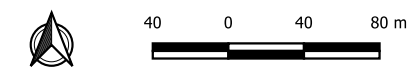

© Hydrology and Water Management Consulting Pty Ltd (HWMC) 2019.  
HWMC endeavours to ensure that the information contained in this figure is correct at the time of publication. Furthermore, HWMC makes no representations, warranties or guarantees about its accuracy.

**Carseldine Urban Village**

**Peak Flood Depths  
Local Catchment Analysis**







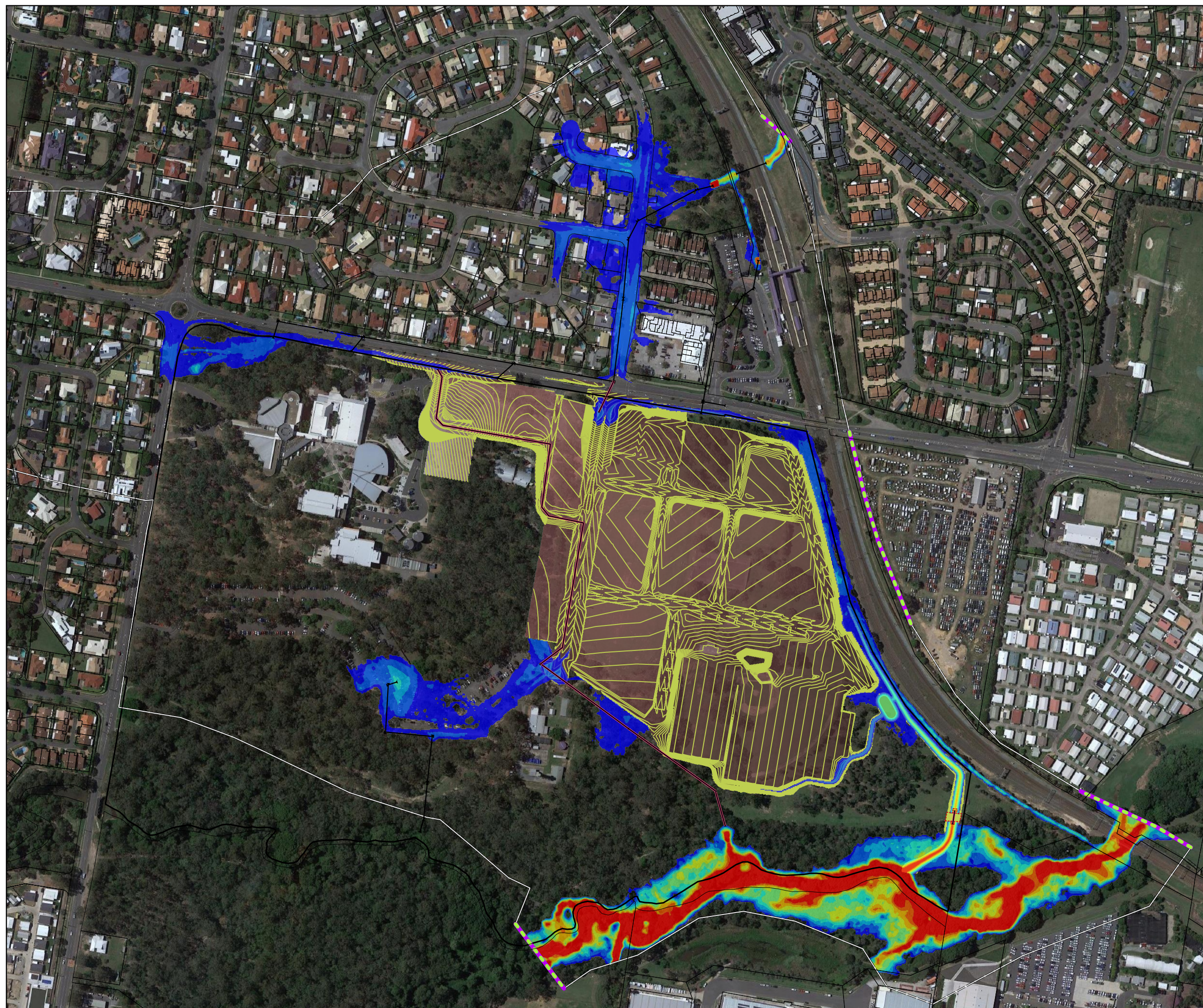

**Proposed Case  
(TUFLOW Case LP02d)**

**50% AEP Event**









Client: Economic Development Queensland



**LEGEND**

-  Site
-  Cadastral Data
-  Model Extent
-  External Boundary
-  Design Contours (0.1m)
-  Proposed Case Z-Point Modifiers
-  1D Pipes - Existing
-  1D Pipes - Proposed

**Depth (m)**

-  ≤ 0.2
-  0.2 - 0.5
-  0.5 - 0.75
-  0.75 - 1
-  1 - 1.25
-  1.25 - 1.5
-  1.5 - 1.75
-  1.75 - 2
-  > 2

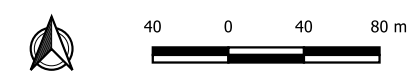

© Hydrology and Water Management Consulting Pty Ltd (HWMC) 2019.  
HWMC endeavours to ensure that the information contained in this figure is correct at the time of publication. Furthermore, HWMC makes no representations, warranties or guarantees about its accuracy.

**Carseldine Urban Village**

**Peak Flood Depths  
Local Catchment Analysis**







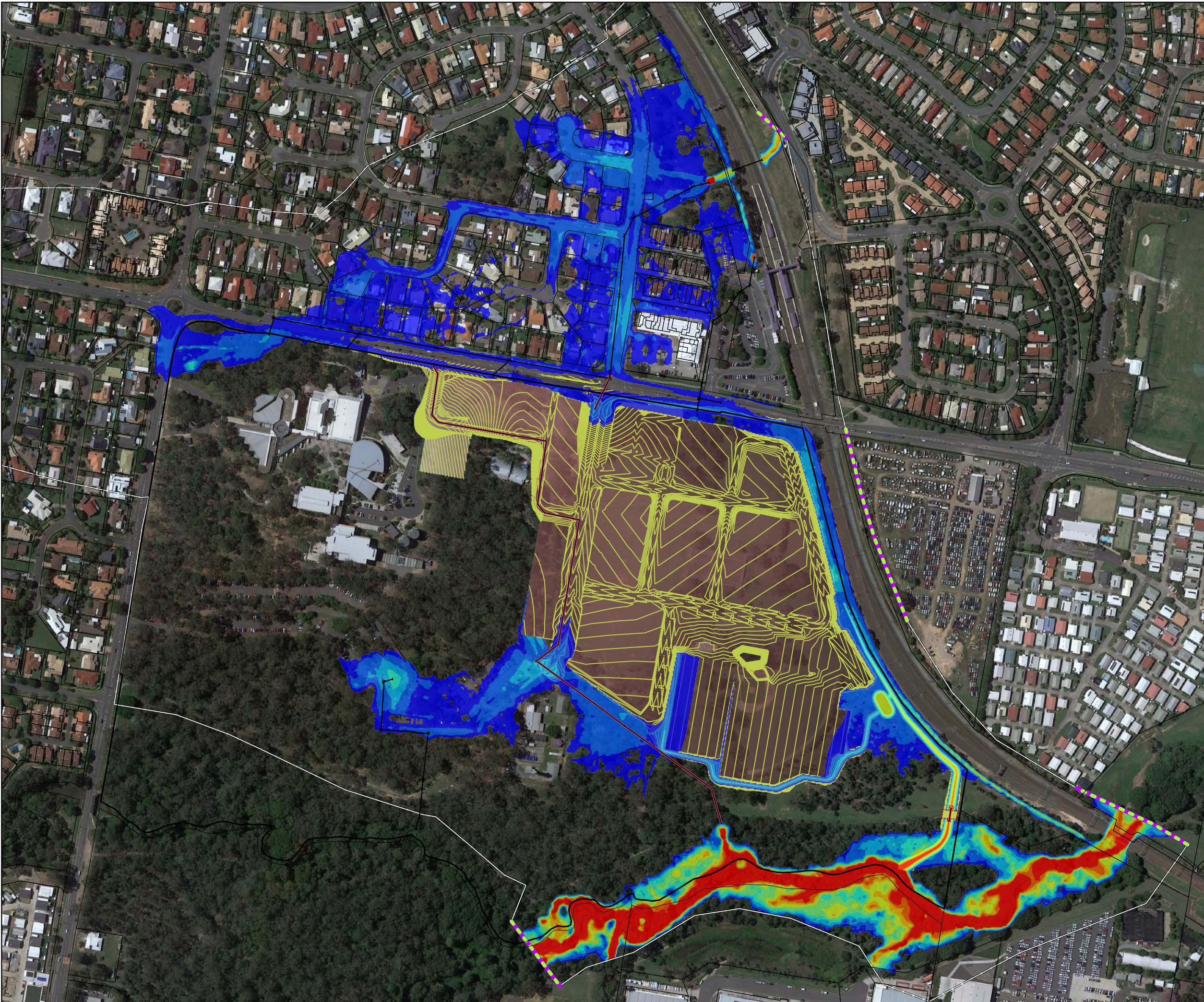

**Proposed Case  
(TUFLOW Case LP02c)**

**5% AEP Event**









Client: Economic Development Queensland



**LEGEND**

-  Site
-  Cadastral Data
-  Model Extent
-  External Boundary
-  Design Contours (0.1m)
-  Proposed Case Z-Point Modifiers
-  1D Pipes - Existing
-  1D Pipes - Proposed

**Depth (m)**

-  ≤ 0.2
-  0.2 - 0.5
-  0.5 - 0.75
-  0.75 - 1
-  1 - 1.25
-  1.25 - 1.5
-  1.5 - 1.75
-  1.75 - 2
-  > 2

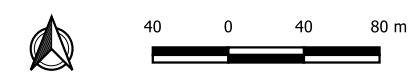

© Hydrology and Water Management Consulting Pty Ltd (HWMC) 2019.  
HWMC endeavours to ensure that the information contained in this figure is correct at the time of publication. Furthermore, HWMC makes no representations, warranties or guarantees about its accuracy.

**Carseldine Urban Village**

**Peak Flood Depths  
Local Catchment Analysis**

**Proposed Case  
(TUFLOW Case LP02c)**

**1% AEP Event**



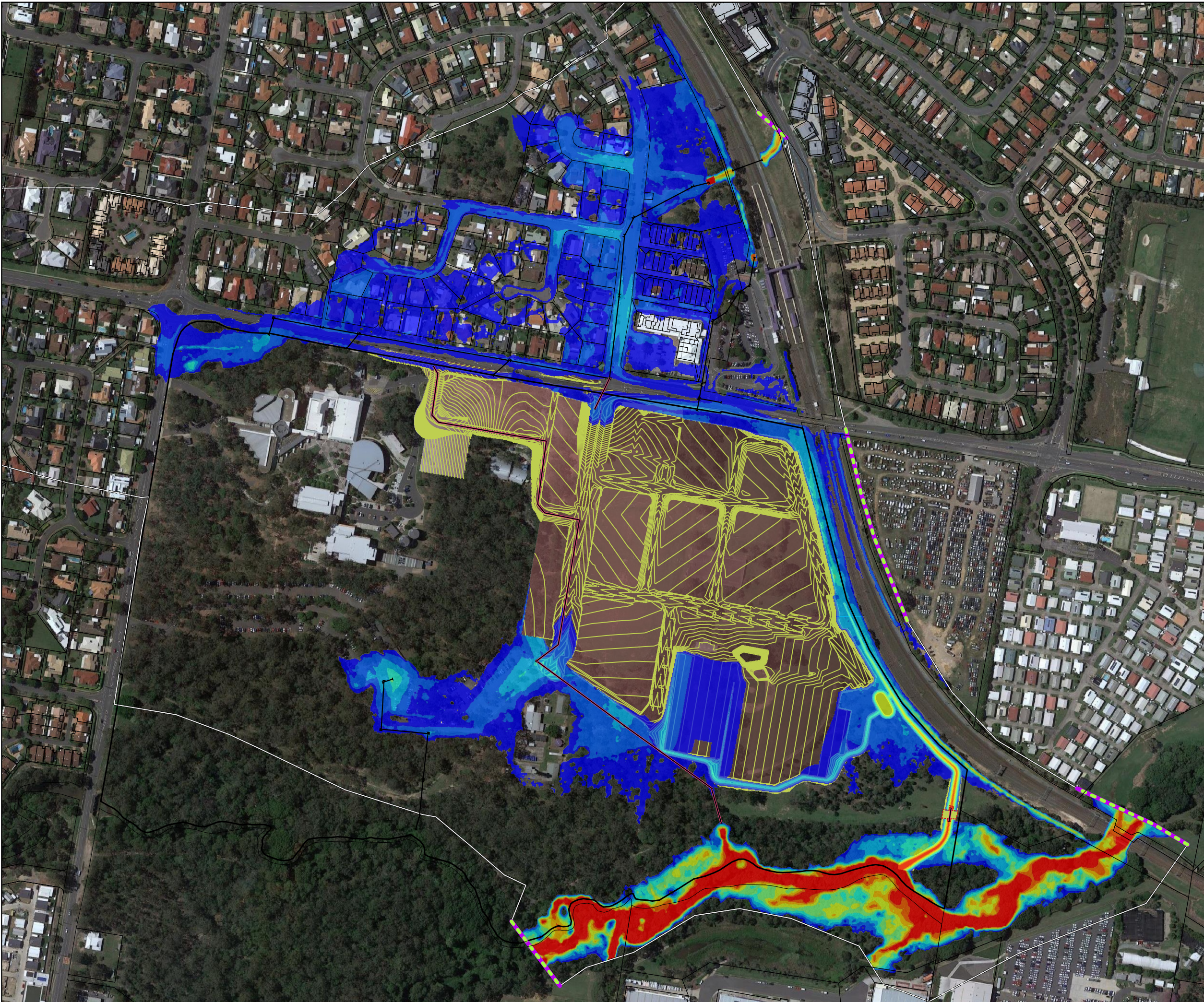





Client: Economic Development Queensland















ATTACHMENT 3 - PEAK FLOOD LEVEL IMPACTS

---

**LEGEND**

-  Site
-  Cadastral Data
-  Model Extent
-  External Boundary
-  Design Conts (0.1m)
-  Developed Case Z-Point Modifiers
-  1D Pipes - Existing
-  1D Pipes - Proposed

**Impact (m)**

-  Less than -0.2
-  -0.1 to -0.2
-  -0.05 to -0.1
-  -0.02 to -0.05
-  -0.01 to -0.02
-  -0.01 to 0.01
-  0.01 to 0.02
-  0.02 to 0.05
-  0.05 to 0.1
-  0.1 to 0.2
-  Greater than 0.2
-  Was Wet - Now Dry
-  Was Dry - Now Wet

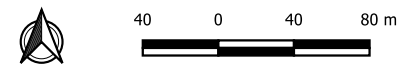

© Hydrology and Water Management Consulting Pty Ltd (HWMC) 2019.  
HWMC endeavours to ensure that the information contained in this figure is correct at the time of publication. Furthermore, HWMC makes no representations, warranties or guarantees about its accuracy.

**Carseldine Urban Village**

**Peak Flood Level Impacts  
Local Catchment Analysis**







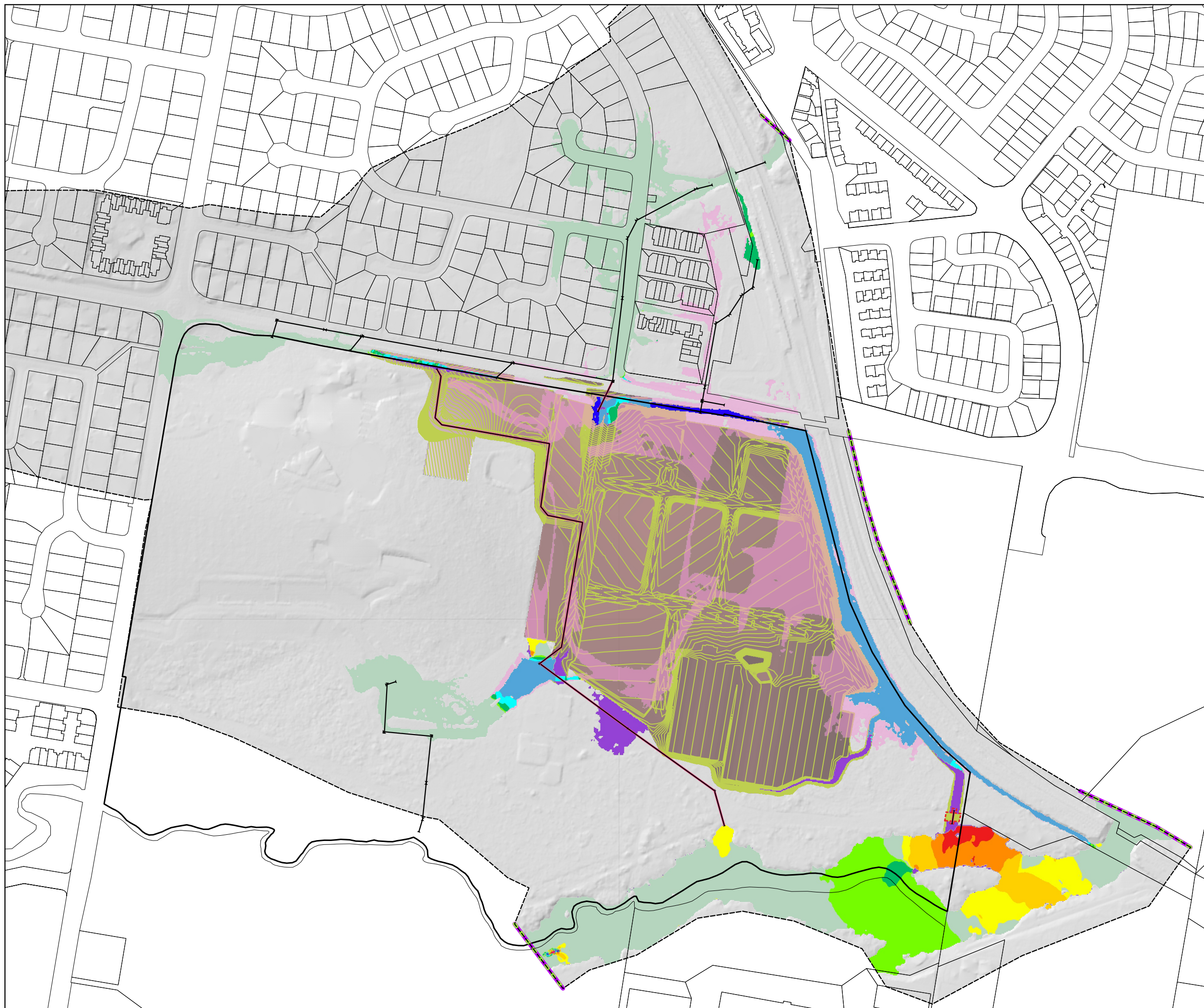

**(TUFLOW Case LP02d Vs LE02c)**

**50% AEP Event**













Client: Economic Development Queensland



**LEGEND**

-  Site
-  Cadastral Data
-  Model Extent
-  External Boundary
-  Design Conts (0.1m)
-  Developed Case Z-Point Modifiers
-  1D Pipes - Existing
-  1D Pipes - Proposed

**Impact (m)**

-  Less than -0.2
-  -0.1 to -0.2
-  -0.05 to -0.1
-  -0.02 to -0.05
-  -0.01 to -0.02
-  -0.01 to 0.01
-  0.01 to 0.02
-  0.02 to 0.05
-  0.05 to 0.1
-  0.1 to 0.2
-  Greater than 0.2
-  Was Wet - Now Dry
-  Was Dry - Now Wet

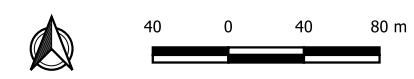

© Hydrology and Water Management Consulting Pty Ltd (HWMC) 2019.  
HWMC endeavours to ensure that the information contained in this figure is correct at the time of publication. Furthermore, HWMC makes no representations, warranties or guarantees about its accuracy.

**Carseldine Urban Village**

**Peak Flood Level Impacts**  
**Local Catchment Analysis**







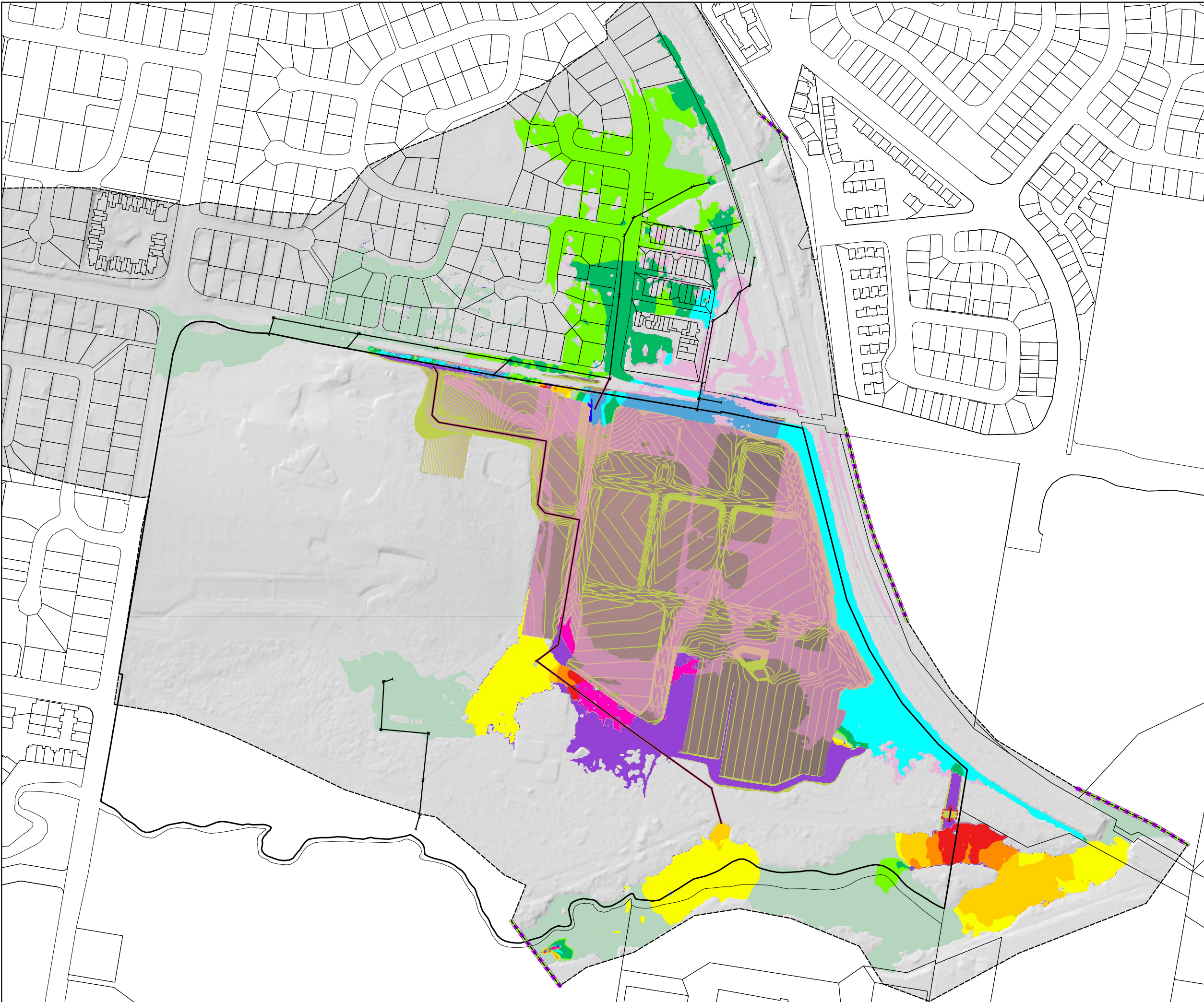

**(TUFLOW Case LP02c Vs LE02b)**

**5% AEP Event**













Client: Economic Development Queensland



**LEGEND**

-  Site
-  Cadastral Data
-  Model Extent
-  External Boundary
-  Design Conts (0.1m)
-  Developed Case Z-Point Modifiers
-  1D Pipes - Existing
-  1D Pipes - Proposed

**Impact (m)**

-  Less than -0.2
-  -0.1 to -0.2
-  -0.05 to -0.1
-  -0.02 to -0.05
-  -0.01 to -0.02
-  -0.01 to 0.01
-  0.01 to 0.02
-  0.02 to 0.05
-  0.05 to 0.1
-  0.1 to 0.2
-  Greater than 0.2
-  Was Wet - Now Dry
-  Was Dry - Now Wet

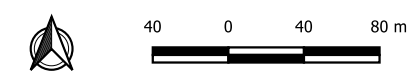

© Hydrology and Water Management Consulting Pty Ltd (HWMC) 2019.  
HWMC endeavours to ensure that the information contained in this figure is correct at the time of publication. Furthermore, HWMC makes no representations, warranties or guarantees about its accuracy.

**Carseldine Urban Village**

**Peak Flood Level Impacts**  
**Local Catchment Analysis**

**(TUFLOW Case LP02c Vs LE02b)**

**1% AEP Event**

Client: Economic Development Queensland

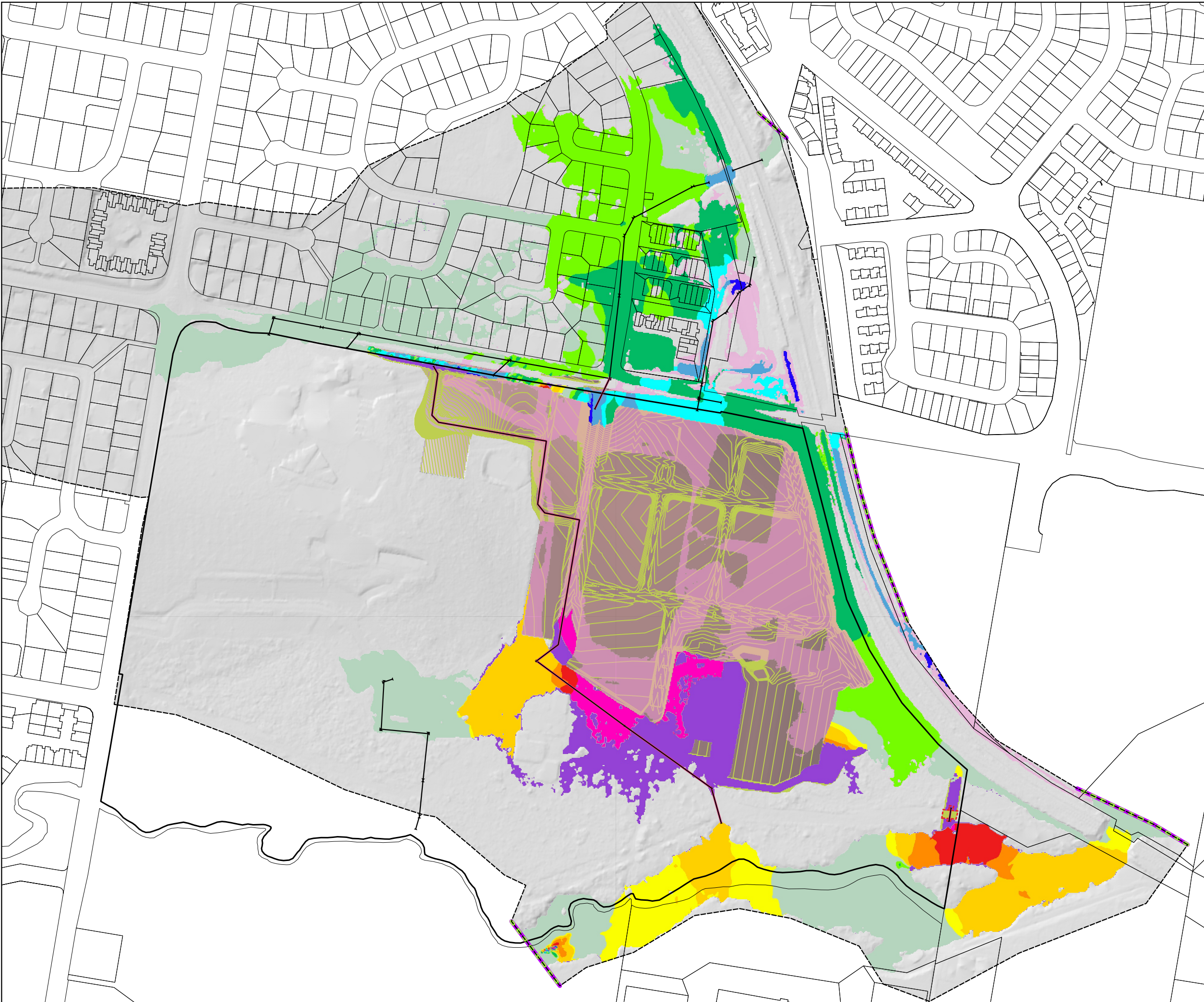



DO NOT SCALE THIS DRAWING  
IF IN DOUBT - ASK!



LOCALITY PLAN

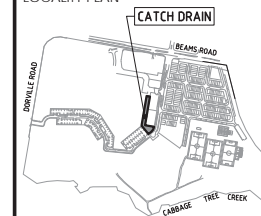

REVISIONS

| No | Description  | Date       | By |
|----|--------------|------------|----|
| A  | FOR APPROVAL | 27.07.2022 | AA |
|    |              |            |    |
|    |              |            |    |
|    |              |            |    |
|    |              |            |    |
|    |              |            |    |
|    |              |            |    |
|    |              |            |    |
|    |              |            |    |
|    |              |            |    |
|    |              |            |    |

Client  
**ECONOMIC DEVELOPMENT QUEENSLAND (EDQ)**

Project  
**CARSELDINE VILLAGE CATCH DRAIN**



Approved  
*M. Shaw* Mark Andrew Shaw BEng (Civil), MIEAust, RPEQ 17544  
2022.07.27 13:32:44 +10'00'

Drawing Title  
**GENERAL LOCALITY PLAN, DRAWING INDEX AND NOTES**

|                   |                         |               |                   |
|-------------------|-------------------------|---------------|-------------------|
| Drawn<br>RW       | Designed<br>JB          | Checked<br>MS | Date<br>JUL '22   |
| Scale<br>AS SHOWN | Drawing No<br>22-106-01 |               | Sheet<br>01 of 12 |
| A1                | Revision<br>A           |               |                   |



**CARSELDINE VILLAGE  
CATCH DRAIN**

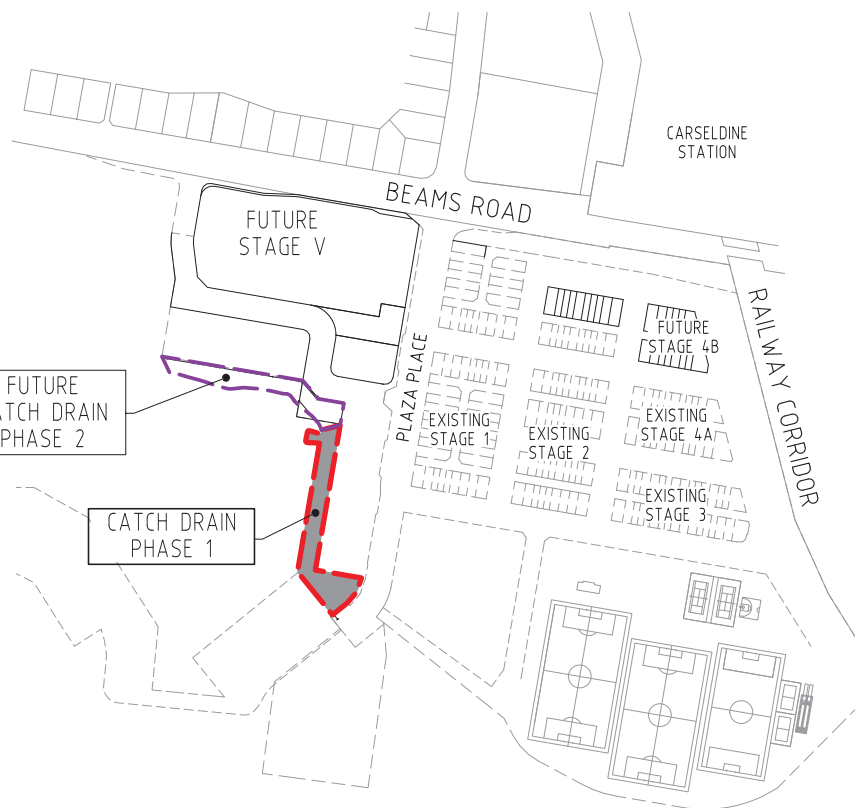

PLAN  
SCALE 1:2000



PLANS AND DOCUMENTS  
 prepared in the PA  
 DEVELOPMENT APPROVAL  
 APPROVAL DATE 20/12/2021  
 Date 10 December 2022

DRAWING INDEX

| DRAWING NO. | DRAWING TITLE                                     |
|-------------|---|
| 22-106-01   | GENERAL - LOCALITY PLAN, DRAWING INDEX AND NOTES  |
| 22-106-02   | GENERAL - SETOUT PLAN                             |
| 22-106-03   | GENERAL - LAYOUT PLAN                             |
| 22-106-04   | EARTHWORKS - CONTOUR PLAN SHEET 1                 |
| 22-106-05   | EARTHWORKS - CONTOUR PLAN SHEET 2                 |
| 22-106-06   | TEMPORARY - TURNAROUND DETAILS                    |
| 22-106-07   | CATCH DRAIN - CROSS SECTIONS PHASE 1 WORKS        |
| 22-106-08   | CATCH DRAIN - CROSS SECTIONS FUTURE PHASE 2 WORKS |
| 22-106-09   | EROSION AND SEDIMENT - CONTOUR PLAN LAYOUT PLAN   |
| 22-106-10   | EROSION AND SEDIMENT - CONTOUR PLAN NOTES         |
| 22-106-11   | EROSION AND SEDIMENT - CONTOUR PLAN DETAILS       |
| 22-106-12   | SAFETY IN DESIGN                                  |

P:\13221\21266 Careldine Village Catch Drain\ACD\13-186-03-GE-SETOUT.dwg Plotfile by AA on 27/07/2022 11:52:23 AM

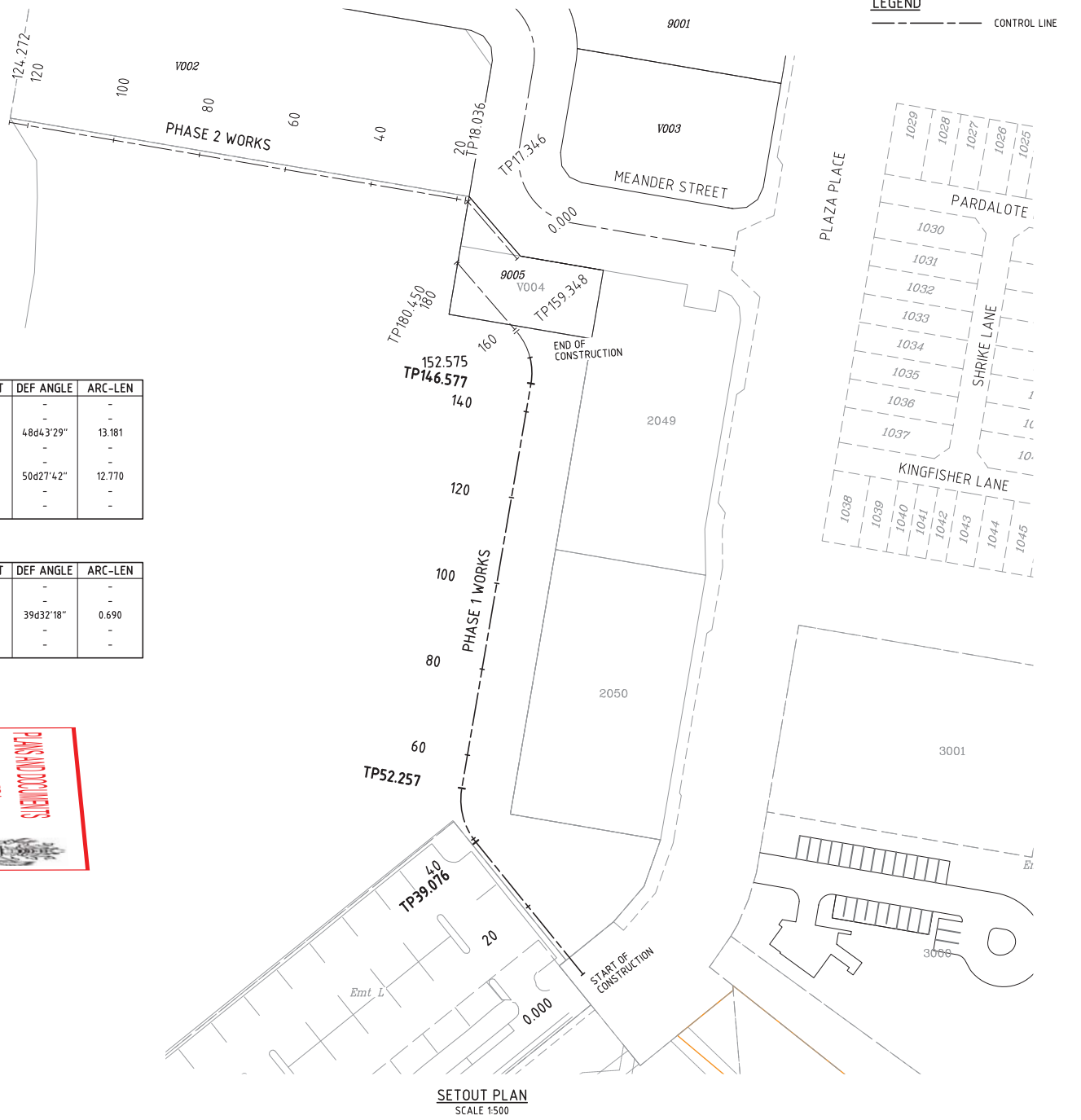

### CATCH DRAIN CONTROL LINE DETAILS

| PT  | CHAINAGE | EASTING    | NORTHING    | BEARING    | RADIUS | TANGENT | DEF ANGLE | ARC-LEN |
|-----|----------|------------|-------------|------------|--------|---------|-----------|---------|
| IP1 | 0.000    | 502587.596 | 6974671.368 | 320d58'50" | -      | -       | -         | -       |
| TC  | 39.076   | 502562.994 | 6974701.727 | 320d58'50" | -      | -       | -         | -       |
| IP2 | 45.666   | 502558.575 | 6974707.181 | -          | 15.500 | 7.019   | 48d43'29" | 13.181  |
| CT  | 52.257   | 502559.759 | 6974714.099 | 9d42'19"   | -      | -       | -         | -       |
| TC  | 146.577  | 502575.659 | 6974807.069 | 9d42'19"   | -      | -       | -         | -       |
| IP3 | 152.963  | 502576.811 | 6974813.804 | -          | 14.500 | 6.833   | 50d27'42" | 12.770  |
| CT  | 159.348  | 502572.351 | 6974818.980 | 319d14'38" | -      | -       | -         | -       |
| IP4 | 180.451  | 502558.574 | 6974834.965 | 319d14'38" | -      | -       | -         | -       |

### FUTURE PHASE 2 WORKS CONTROL LINE DETAILS

| PT  | CHAINAGE | EASTING    | NORTHING    | BEARING    | RADIUS | TANGENT | DEF ANGLE | ARC-LEN |
|-----|----------|------------|-------------|------------|--------|---------|-----------|---------|
| IP1 | 0.000    | 502572.482 | 6974835.677 | 319d14'38" | -      | -       | -         | -       |
| TC  | 17.346   | 502561.157 | 6974848.817 | 319d14'38" | -      | -       | -         | -       |
| IP2 | 17.691   | 502560.923 | 6974849.089 | -          | 1.000  | 0.359   | 39d32'18" | 0.690   |
| CT  | 18.036   | 502560.569 | 6974849.150 | 279d42'19" | -      | -       | -         | -       |
| IP3 | 124.272  | 502455.853 | 6974867.059 | 279d42'19" | -      | -       | -         | -       |



DO NOT SCALE THIS DRAWING  
IF IN DOUBT - ASK!

NORTH

LOCALITY PLAN

REVISIONS

| No | Description  | Date       | By |
|----|--------------|------------|----|
| A  | FOR APPROVAL | 27.07.2022 | AA |
|    |              |            |    |
|    |              |            |    |
|    |              |            |    |
|    |              |            |    |
|    |              |            |    |
|    |              |            |    |
|    |              |            |    |
|    |              |            |    |
|    |              |            |    |
|    |              |            |    |

Client

**ECONOMIC DEVELOPMENT QUEENSLAND (EDQ)**

Project

**CARSELDINE VILLAGE CATCH DRAIN**

ABN 35 112 53 611  
11, 62 Astor Terrace  
Spring Hill Q 4000  
07 3017 1900  
[www.knigroup.com.au](http://www.knigroup.com.au)

Approved

*M. Shaw* Mark Andrew Shaw BEng (Civil), MIEAust, RPEQ 17544 2022.07.27 13:33:00 +10'00'

Drawing title

**GENERAL SETOUT PLAN**

| Drawn | Designed | Checked | Date    |
|-------|----------|---------|---------|
| RW    | JB       | MS      | JUL '22 |

| Scale    | Sheet    |
|----------|----------|
| AS SHOWN | 02 of 12 |

| Drawing No | Revision |
|------------|----------|
| A1         | A        |



**LEGEND**

- EXTENT OF WORKS PHASE 1
- FUTURE EXTENT OF WORKS PHASE 2
- CONTROL LINE
- FINISHED SURFACE CONTOURS
- EXISTING SURFACE CONTOURS
- BATTER LINE
- EXISTING SURVEYED EDGE OF VEGETATION TRUNK OF TREE LINE
- 4m WIDE GRAVEL ACCESS TRACK
- FUTURE 4m WIDE GRAVEL ACCESS TRACK

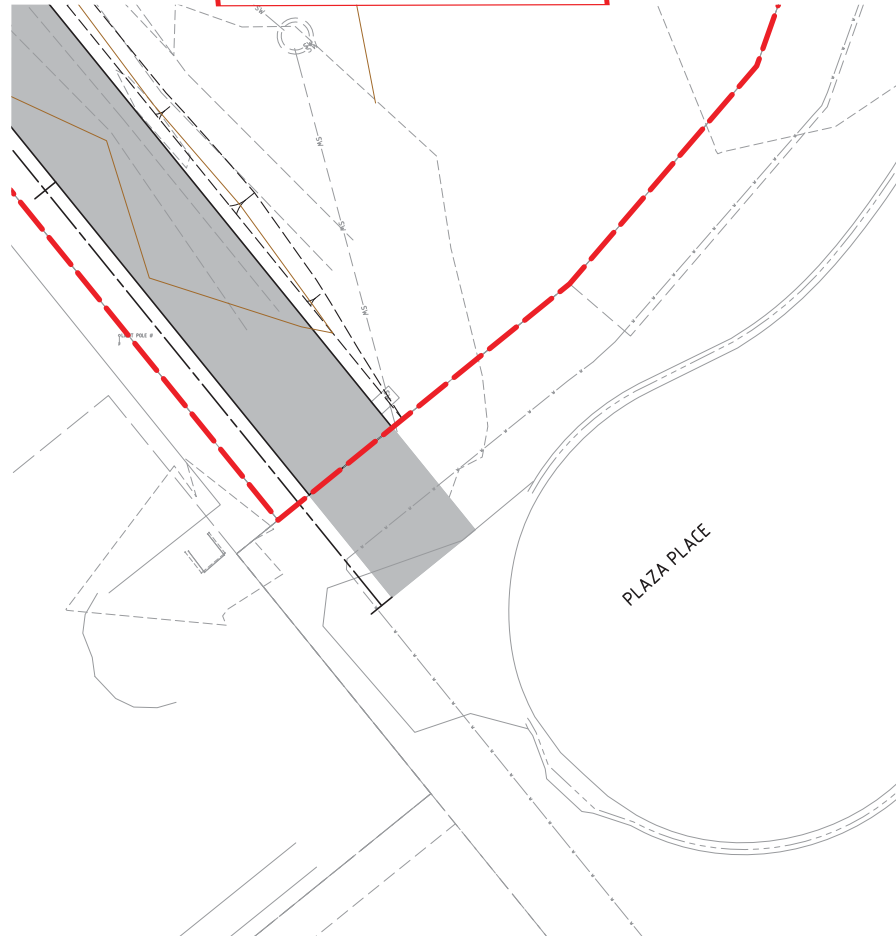
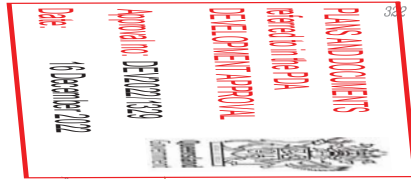

**DETAIL 'A'**  
SCALE 1:100

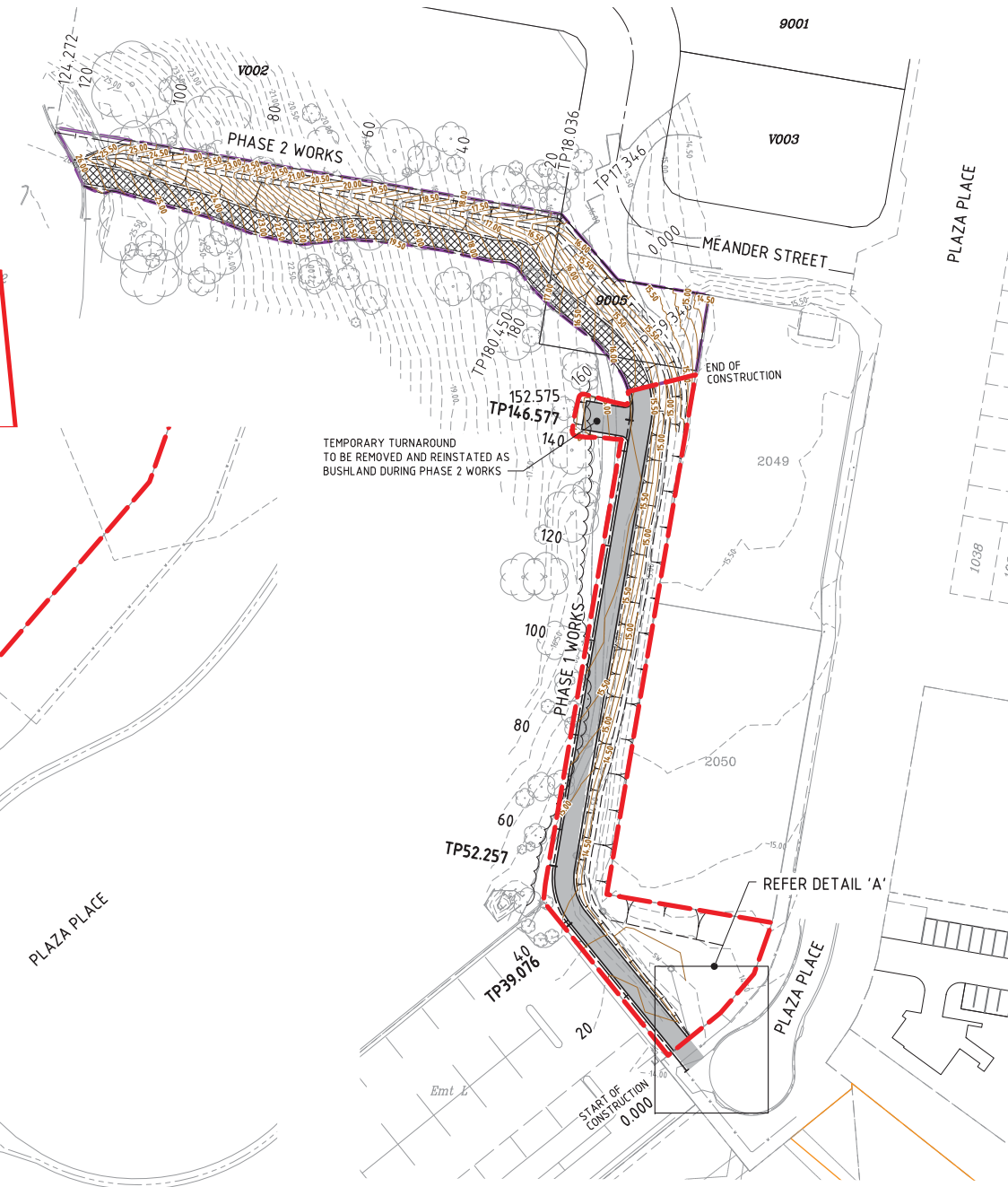

**LAYOUT PLAN**  
SCALE 1:500

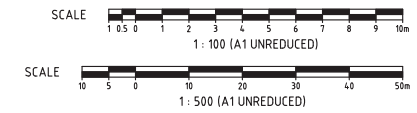

DO NOT SCALE THIS DRAWING IF IN DOUBT - ASK!

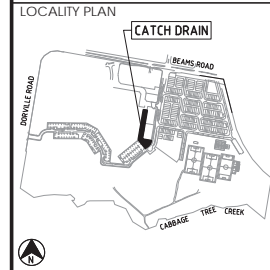

REVISIONS

| No | Description  | Date       | By |
|----|--------------|------------|----|
| A  | FOR APPROVAL | 27.07.2022 | AA |
|    |              |            |    |
|    |              |            |    |
|    |              |            |    |
|    |              |            |    |
|    |              |            |    |
|    |              |            |    |
|    |              |            |    |
|    |              |            |    |
|    |              |            |    |
|    |              |            |    |
|    |              |            |    |
|    |              |            |    |
|    |              |            |    |

Client  
**ECONOMIC DEVELOPMENT QUEENSLAND (EDQ)**

Project  
**CARSELDINE VILLAGE CATCH DRAIN**



Approved  
*M. Shaw* Mark Andrew Shaw BEng (Civil), MIEAust, RPEQ 17544  
2022.07.27 13:33:10 +10'00'

Drawing Title  
**GENERAL LAYOUT PLAN**

| Drawn          | Designed | Checked            | Date           |
|----------------|----------|--------------------|----------------|
| RW             | JB       | MS                 | JUL '22        |
| Scale AS SHOWN |          |                    | Sheet 03 of 12 |
| Drawing No A1  |          | Revision 22-106-03 | Revision A     |

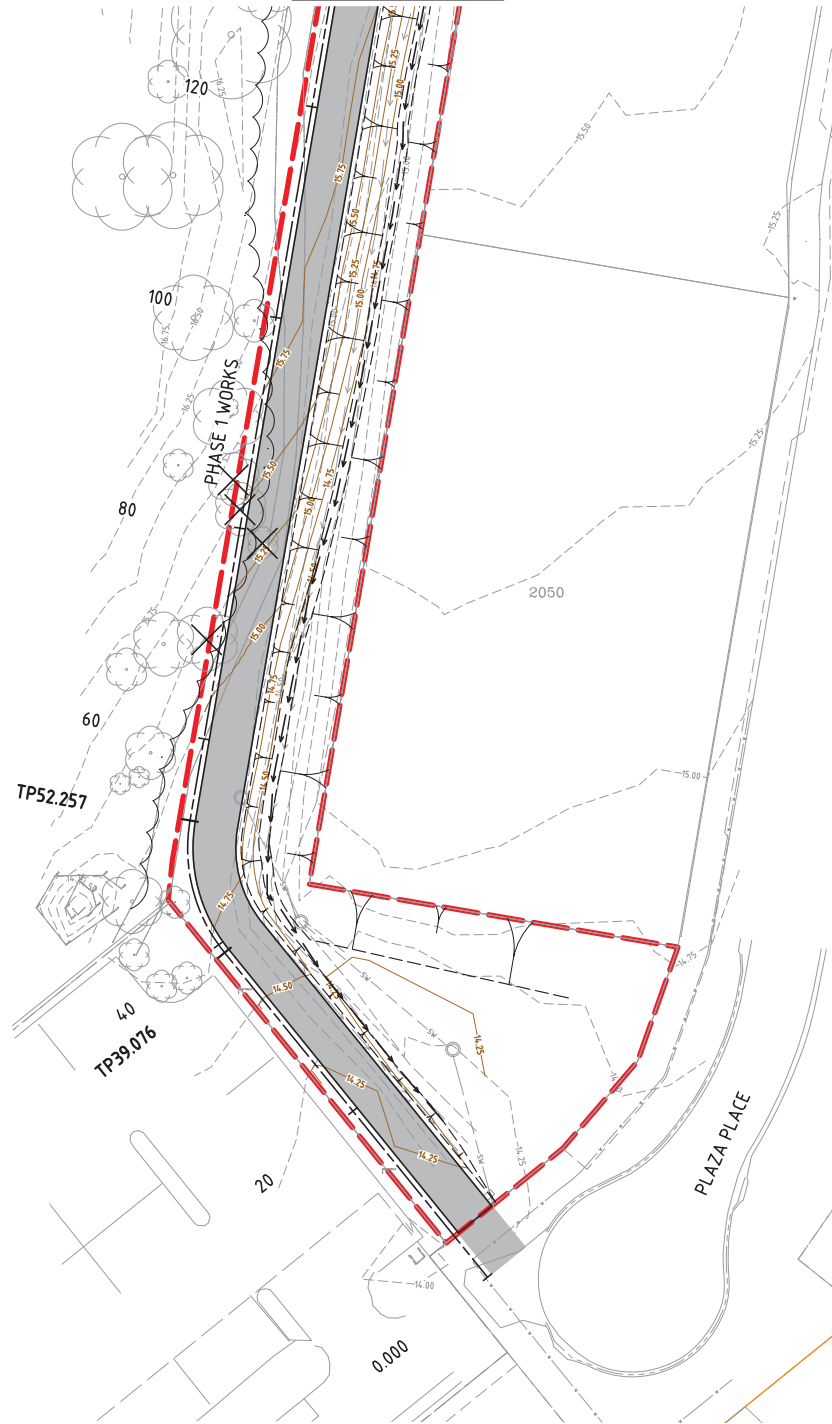

LEGEND

- EXTENT OF WORKS PHASE 1
- FUTURE EXTENT OF WORKS PHASE 2
- CONTROL LINE
- CATCH DRAIN
- FINISHED SURFACE CONTOURS
- EXISTING SURFACE CONTOURS
- BATTER LINE
- EXISTING SURVEYED EDGE OF VEGETATION TRUNK OF TREE LINE
- 4m WIDE GRAVEL ACCESS TRACK
- FUTURE 4m WIDE GRAVEL ACCESS TRACK
- EXISTING TREE
- EXISTING TREE TO BE REMOVED TO BE CONFIRM BY OTHERS

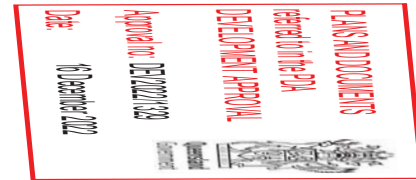

DO NOT SCALE THIS DRAWING  
IF IN DOUBT - ASK!



LOCALITY PLAN

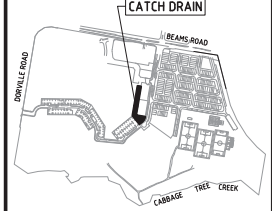

REVISIONS

| No | Description  | Date       | By |
|----|--------------|------------|----|
| A  | FOR APPROVAL | 27.07.2022 | AA |
|    |              |            |    |
|    |              |            |    |
|    |              |            |    |
|    |              |            |    |
|    |              |            |    |
|    |              |            |    |
|    |              |            |    |
|    |              |            |    |
|    |              |            |    |
|    |              |            |    |
|    |              |            |    |

Client  
**ECONOMIC DEVELOPMENT QUEENSLAND (EDQ)**

Project  
**CARSELDINE VILLAGE CATCH DRAIN**



Approved  
*M. Shaw* Mark Andrew Shaw BEng  
(Civil), MIEAust, RPEQ 17544  
2022.07.27 13:33:19 +10'00'

Drawing title  
**EARTHWORKS CONTOUR PLAN SHEET 1**

| Drawn | Designed  | Checked  | Date           |
|-------|-----------|----------|----------------|
| RW    | JB        | MS       | JUL '22        |
| Scale | AS SHOWN  |          | Sheet 04 of 12 |
| A1    | 22-106-04 | Revision | A              |

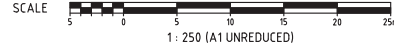

**EARTHWORKS CONTOUR PLAN**  
SCALE 1:250

P:\32022\22106 Carlseldine Village Catch Drain\ACAD\22-106-05-EARTHWORKS.dwg Plotted by: AA on 27/07/2022 15:55:25 AM

DO NOT SCALE THIS DRAWING  
IF IN DOUBT - ASK!



LOCALITY PLAN

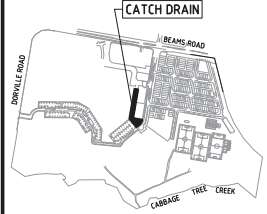

REVISIONS

| No | Description  | Date       | By |
|----|--------------|------------|----|
| A  | FOR APPROVAL | 27.07.2022 | AA |
|    |              |            |    |
|    |              |            |    |
|    |              |            |    |
|    |              |            |    |
|    |              |            |    |
|    |              |            |    |
|    |              |            |    |

Client  
**ECONOMIC DEVELOPMENT QUEENSLAND (EDQ)**

Project  
**CARSELDINE VILLAGE CATCH DRAIN**



Approved  
*M. Shaw* Mark Andrew Shaw BEng (Civil), MIE Aust, RPEQ 17544, 2022.07.27 13:33:30 +10'00'

Drawing title  
**EARTHWORKS CONTOUR PLAN SHEET 2**

| Drawn      | Designed  | Checked | Date     |
|------------|-----------|---------|----------|
| RW         | JB        | MS      | JUL '22  |
| Scale      | Sheet     |         | Revision |
| AS SHOWN   | 05 of 12  |         |          |
| Drawing No | Revision  |         |          |
| A1         | 22-106-05 |         | A        |

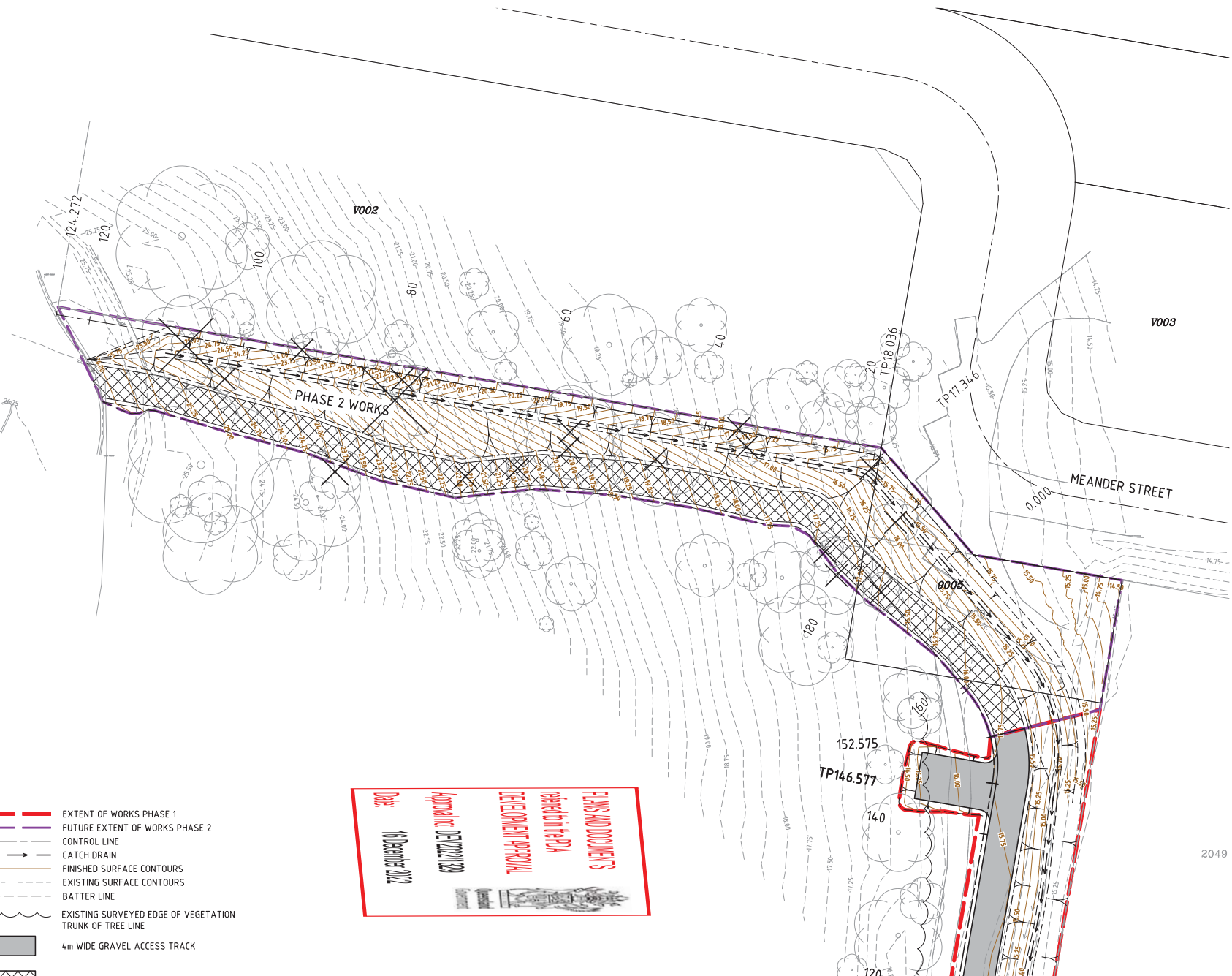

**LEGEND**

- EXTENT OF WORKS PHASE 1
- FUTURE EXTENT OF WORKS PHASE 2
- CONTROL LINE
- CATCH DRAIN
- FINISHED SURFACE CONTOURS
- EXISTING SURFACE CONTOURS
- BATTER LINE
- EXISTING SURVEYED EDGE OF VEGETATION TRUNK OF TREE LINE
- 4m WIDE GRAVEL ACCESS TRACK
- FUTURE 4m WIDE GRAVEL ACCESS TRACK
- EXISTING TREE
- EXISTING TREE TO BE REMOVED TO BE CONFIRM BY OTHERS

**PLANS AND DOCUMENTS**

referred to in the EPA

DEVELOPMENT APPROVAL

16/12/2021 12:29

Date: 16 December 2022

JOINS KNG DWG No 22-106-04 **EARTHWORKS CONTOUR PLAN**



DO NOT SCALE THIS DRAWING  
IF IN DOUBT - ASK!



LOCALITY PLAN

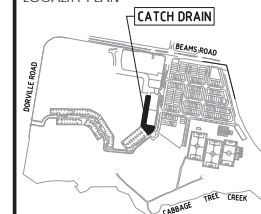

REVISIONS

| No | Description  | Date       | By |
|----|--------------|------------|----|
| A  | FOR APPROVAL | 27.07.2022 | AA |
|    |              |            |    |
|    |              |            |    |
|    |              |            |    |
|    |              |            |    |
|    |              |            |    |
|    |              |            |    |
|    |              |            |    |
|    |              |            |    |
|    |              |            |    |
|    |              |            |    |
|    |              |            |    |

Client  
**ECONOMIC DEVELOPMENT QUEENSLAND (EDQ)**

Project  
**CARSELDINE VILLAGE CATCH DRAIN**

**kn group**  
 ABN 35 112 53 611  
 11, 62 Astor Terrace  
 Spring Hill Q 4000  
 07 3017 1900  
[www.knigroup.com.au](http://www.knigroup.com.au)

Approved  
*M. Shaw* Mark Andrew Shaw BEng (Civil), MIEAust, RPEQ 17544  
 2022.07.27 13:33:39 +10'00'

Drawing title  
**TEMPORARY TURNAROUND DETAILS**

|                   |                         |               |                   |
|-------------------|-------------------------|---------------|-------------------|
| Drawn<br>RW       | Designed<br>JB          | Checked<br>MS | Date<br>JUL '22   |
| Scale<br>AS SHOWN | Drawing No<br>22-106-06 |               | Sheet<br>06 of 12 |
| A1                | Revision<br>A           |               |                   |

**LEGEND**

- EXTENT OF WORKS PHASE 1
- FINISHED SURFACE CONTOURS
- EXISTING SURFACE CONTOURS
- - - - BATTER LINE
- - - - FUTURE BATTER LINE
- EXISTING SURVEYED EDGE OF VEGETATION
- TRUNK OF TREE LINE
- GRAVEL ACCESS TRACK

**NOTE:**  
 TEMPORARY TURNAROUND  
 TO BE REMOVED AND REINSTATED AS  
 BUSHLAND DURING PHASE 2 WORKS

**PLANS AND DOCUMENTS**  
**Referred to in the EPA**  
**DEVELOPMENT APPROVAL**  
**Approved on: 26/07/2022**  
**Date: 01 December 2022**

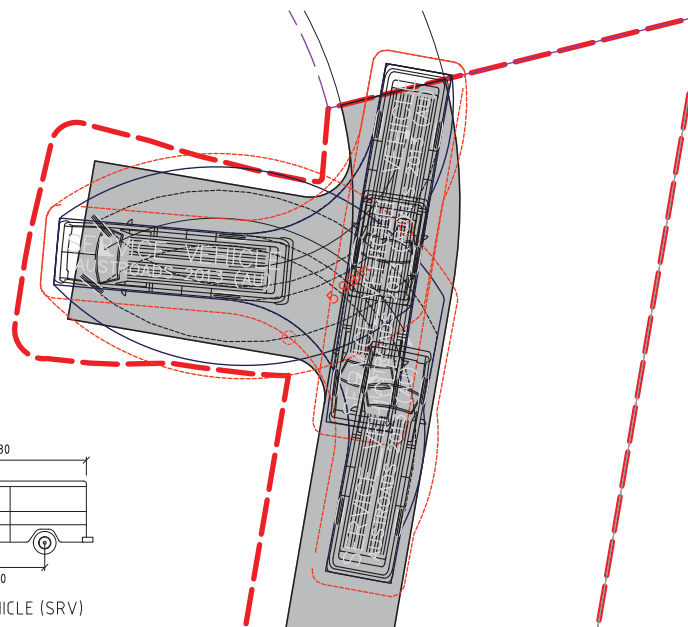

TEMPORARY TURNAROUND TURN PATHS  
SCALE 1:100

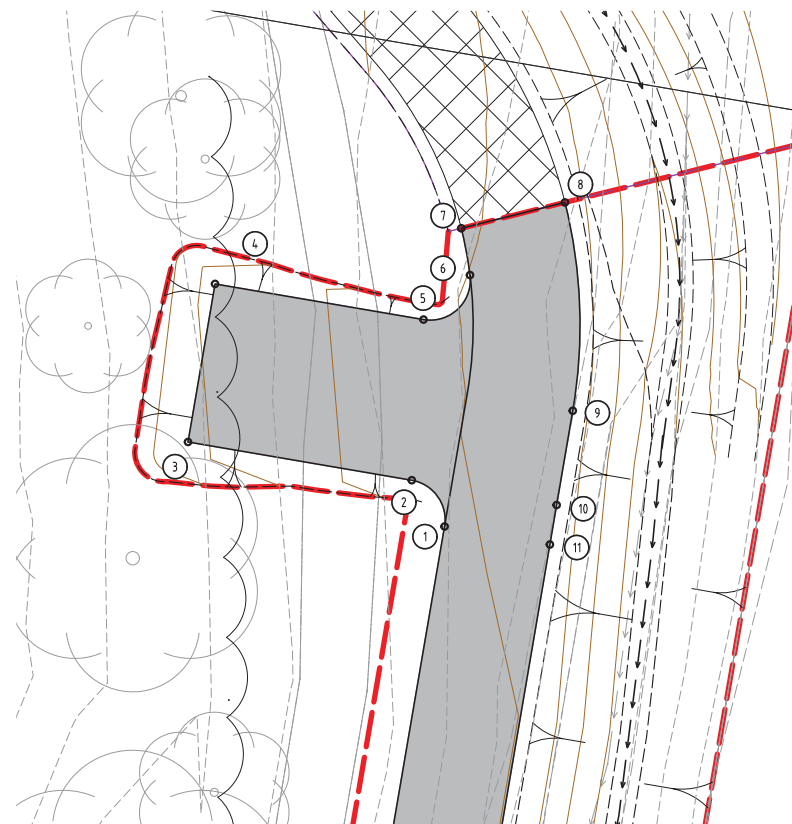

TEMPORARY TURNAROUND DETAIL  
SCALE 1:100

**SETOUT TABLE**

| PT No. | EASTING    | NORTHING    | LEVEL  |
|--------|------------|-------------|--------|
| 1      | 502575.296 | 6974801.980 | 15.816 |
| 2      | 502574.071 | 6974803.711 | 15.863 |
| 3      | 502565.695 | 6974805.144 | 16.291 |
| 4      | 502566.706 | 6974811.058 | 16.214 |
| 5      | 502574.508 | 6974809.724 | 15.818 |
| 6      | 502576.249 | 6974811.390 | 15.745 |
| 7      | 502575.922 | 6974813.141 | 15.789 |
| 8      | 502579.803 | 6974814.108 | 15.590 |
| 9      | 502580.095 | 6974806.311 | 15.546 |
| 10     | 502579.492 | 6974802.784 | 15.588 |
| 11     | 502579.239 | 6974801.306 | 15.616 |

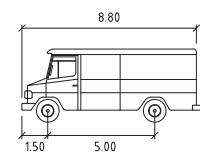
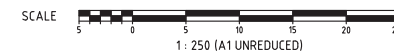

**SERVICE VEHICLE (SRV)**

Width : 2.50 meters  
 Track : 2.50  
 Lock to Lock Time : 6.0  
 Steering Angle : 38.7

**PLANS AND DOCUMENTS**  
 prepared for the PIA  
 DEVELOPMENT APPROVAL  
 Approved on: 08 December 2022  
 Date: 10 December 2022

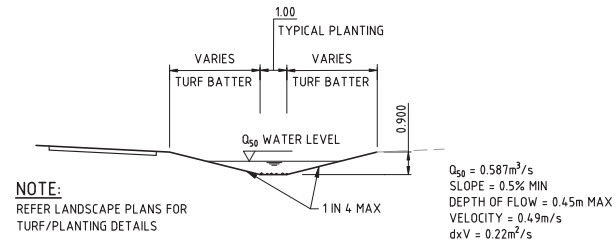
**CATCH DRAIN TYPICAL SECTION**  
NTS.

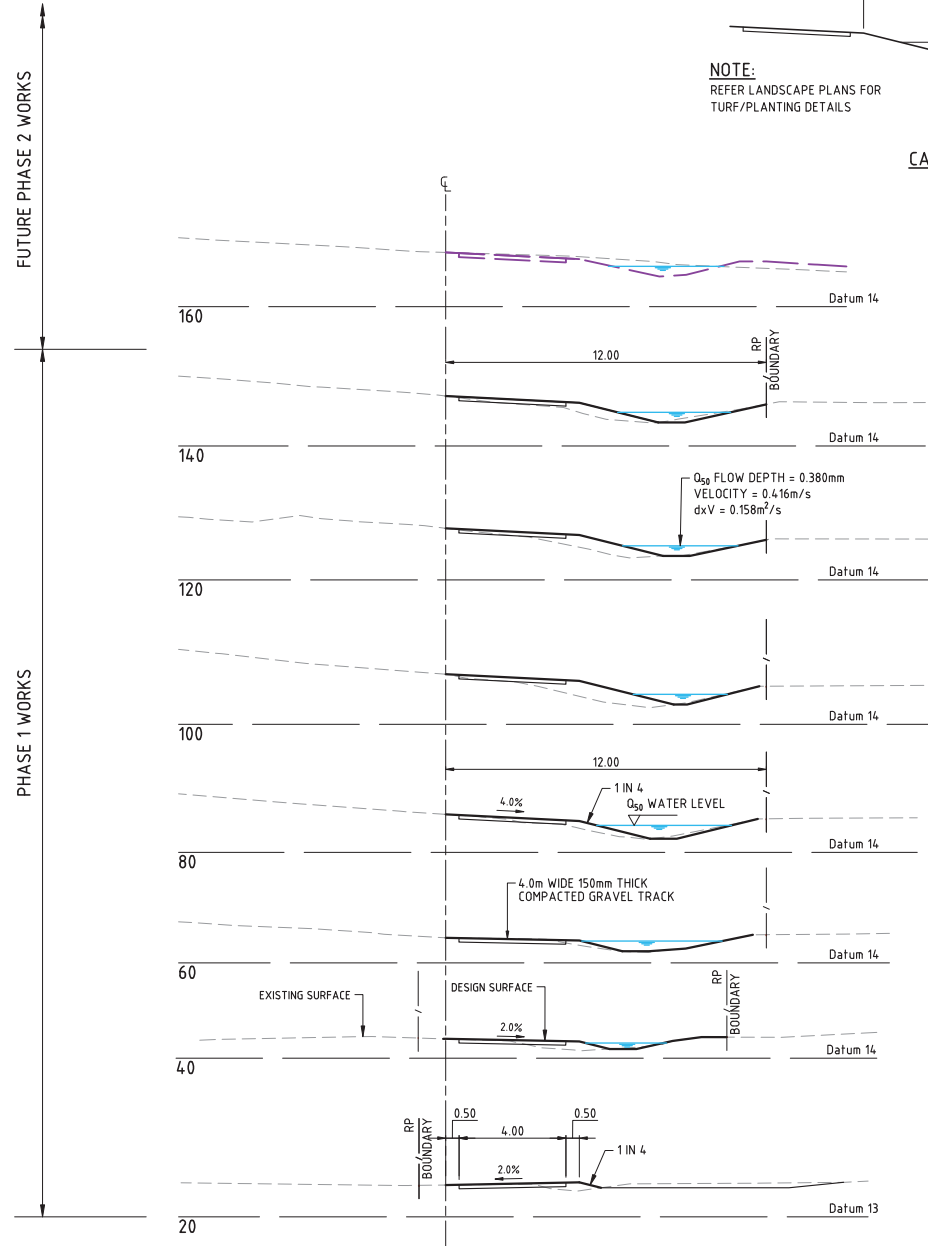

**CROSS SECTIONS - CATCH DRAIN PHASE 1 WORKS**  
SCALE 1 : 100

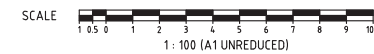

DO NOT SCALE THIS DRAWING  
IF IN DOUBT - ASK!



LOCALITY PLAN

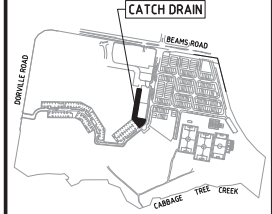

REVISIONS

| No | Description  | Date       | By |
|----|--------------|------------|----|
| A  | FOR APPROVAL | 27/07/2022 | AA |

Client

ECONOMIC  
DEVELOPMENT  
QUEENSLAND (EDQ)

Project

CARSELDINE VILLAGE  
CATCH DRAIN



ABN 35 112 53 611  
 11, 62 Astor Terrace  
 Spring Hill Q 4000  
 07 3017 1900  
[www.knigroup.com.au](http://www.knigroup.com.au)

Approved

  
 Mark Andrew Shaw BEng  
 (Civil), MIE Aust, RPEQ 17544  
 2022.07.27 13:33:49 +10'00'

Drawing title

CATCH DRAIN  
CROSS SECTIONS  
PHASE 1 WORKS

| Drawn | Designed | Checked | Date    |
|-------|----------|---------|---------|
| RW    | JB       | MS      | JUL '22 |

| Scale    | Sheet    |
|----------|----------|
| AS SHOWN | 07 of 12 |

| Drawing No | Revision  |
|------------|-----------|
| A1         | 22-106-07 |

P:\132021\22706 Carseeldine Village Catch Drain\ACD122-106-07-08-XS.dwg Plotted by: AA on 27/07/2022 15:53:04

DO NOT SCALE THIS DRAWING  
IF IN DOUBT - ASK!



LOCALITY PLAN

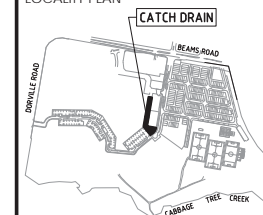

REVISIONS

| No | Description  | Date       | By |
|----|--------------|------------|----|
| A  | FOR APPROVAL | 27/07/2022 | AA |
|    |              |            |    |
|    |              |            |    |
|    |              |            |    |
|    |              |            |    |
|    |              |            |    |
|    |              |            |    |
|    |              |            |    |
|    |              |            |    |
|    |              |            |    |
|    |              |            |    |
|    |              |            |    |
|    |              |            |    |
|    |              |            |    |
|    |              |            |    |
|    |              |            |    |
|    |              |            |    |
|    |              |            |    |
|    |              |            |    |
|    |              |            |    |
|    |              |            |    |
|    |              |            |    |
|    |              |            |    |
|    |              |            |    |
|    |              |            |    |
|    |              |            |    |

Client  
**ECONOMIC DEVELOPMENT QUEENSLAND (EDQ)**

Project  
**CARSELDINE VILLAGE CATCH DRAIN**

Approved  
*M. Shaw* Mark Andrew Shaw BEng (Civil), MIEAust, RPEQ 17544 2022.07.27 13:34:01 +10'00'

Drawing title  
**CATCH DRAIN CROSS SECTIONS FUTURE PHASE 2 WORKS**

| Drawn | Designed             | Checked  | Date     |
|-------|----------------------|----------|----------|
| RW    | JB                   | MS       | JUL '22  |
| Scale | AS SHOWN             |          | Sheet    |
| A1    | Drawing No 22-106-08 |          | 08 of 12 |
|       |                      | Revision | A        |

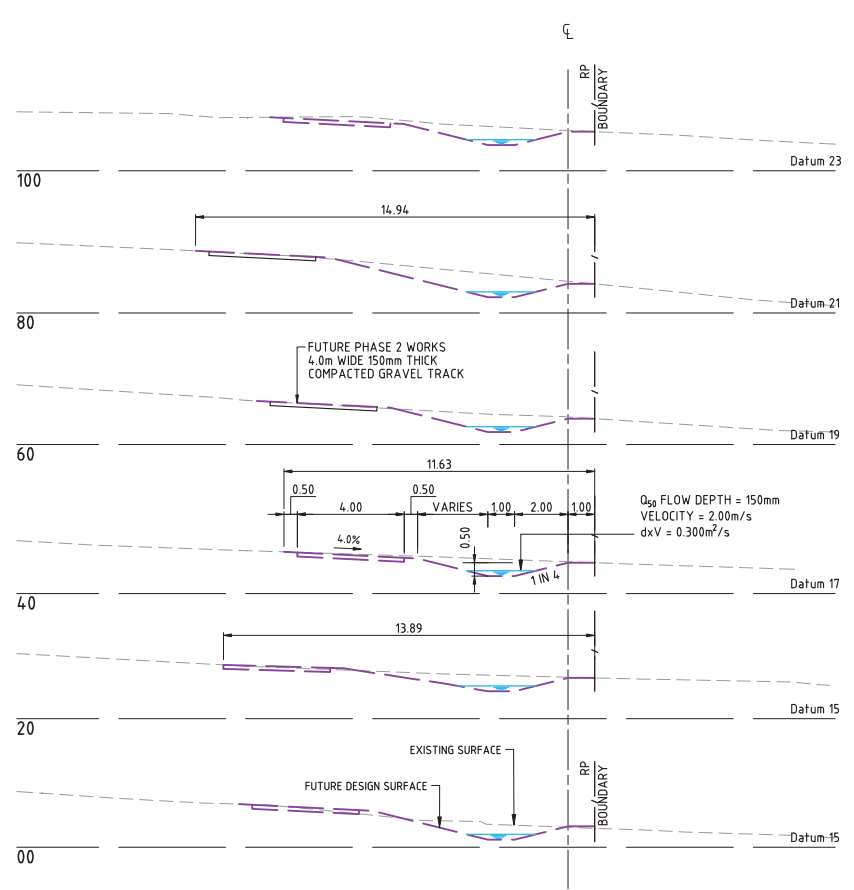

SCALE 1: 100

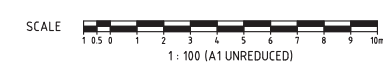

**PLANS AND DOCUMENTS**

Approved on the PPA  
DEVELOPMENT APPROVAL

Approved on: 12/07/2022

Date: 13 October 2022



DO NOT SCALE THIS DRAWING  
IF IN DOUBT - ASK!



LOCALITY PLAN

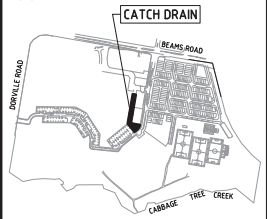

REVISIONS

| No | Description  | Date       | By |
|----|--------------|------------|----|
| A  | FOR APPROVAL | 27.07.2022 | AA |
|    |              |            |    |
|    |              |            |    |
|    |              |            |    |

Client

ECONOMIC  
DEVELOPMENT  
QUEENSLAND (EDQ)

Project

CARSELDINE VILLAGE  
CATCH DRAIN



Approved

*M. Shaw* Mark Andrew Shaw BEng  
(Civil), MIEAust, RPEQ 17544  
2022.07.27 13:34:12 +10'00'

Drawing title

EROSION AND SEDIMENT  
CONTOUR PLAN  
LAYOUT PLAN

|             |                |               |                 |
|-------------|----------------|---------------|-----------------|
| Drawn<br>RW | Designed<br>JB | Checked<br>MS | Date<br>JUL '22 |
|-------------|----------------|---------------|-----------------|

|                   |                   |
|-------------------|-------------------|
| Scale<br>AS SHOWN | Sheet<br>09 of 12 |
|-------------------|-------------------|

|                  |                       |               |
|------------------|-----------------------|---------------|
| Drawing No<br>A1 | Revision<br>22-106-09 | Revision<br>A |
|------------------|-----------------------|---------------|

LEGEND

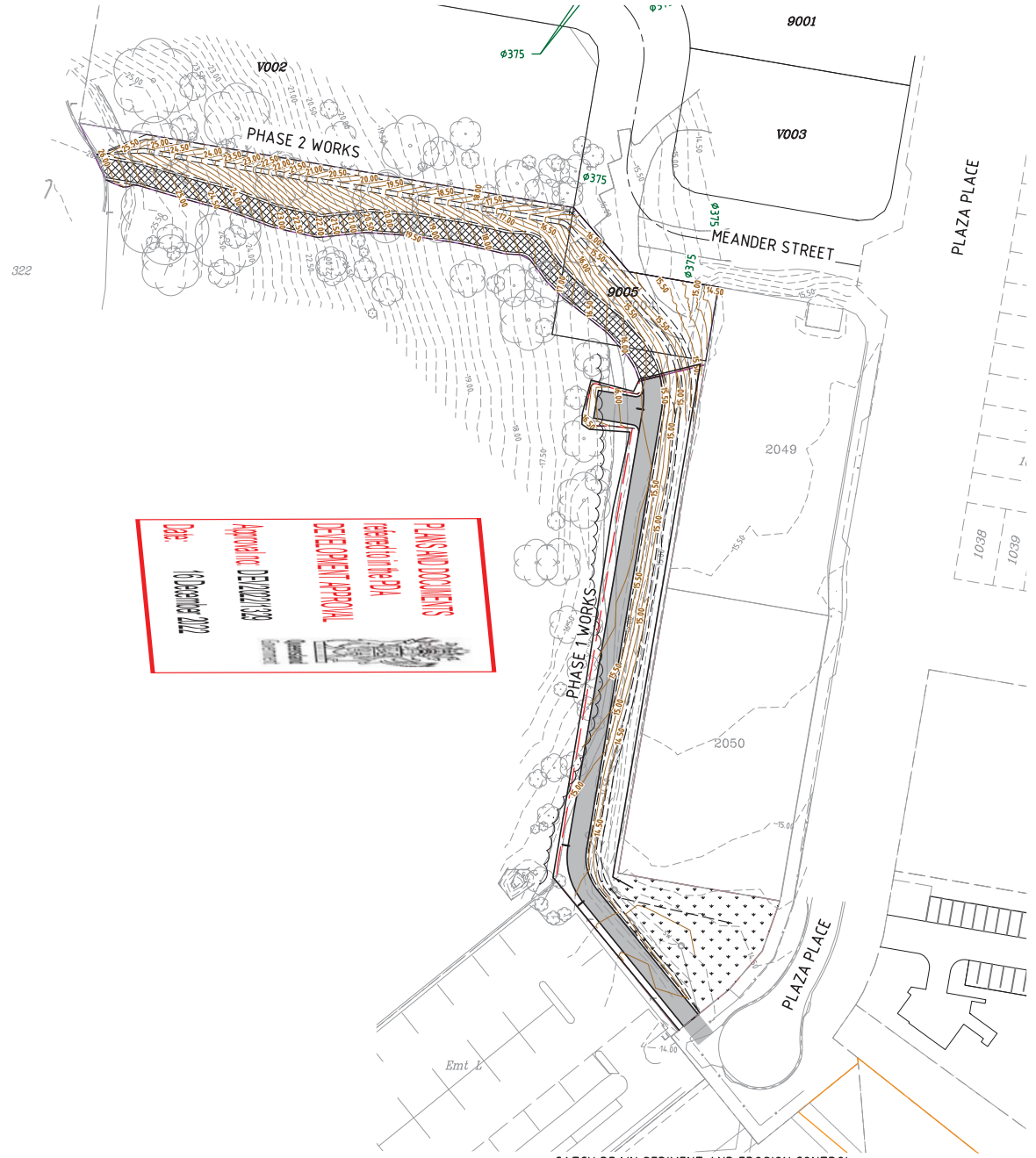
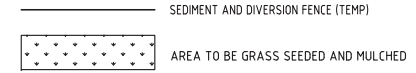

**PLANS DOCUMENTS**

Approved in the PA  
DEVELOPMENT APPROVAL

Approved in the DA  
DEVELOPMENT APPROVAL

Date: 10 October 2022

CATCH DRAIN SEDIMENT AND EROSION CONTROL  
LAYOUT PLAN  
SCALE 1:500

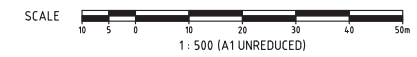

**EROSION AND SEDIMENT CONTROL PROGRAM**

- THIS PROGRAM AND ASSOCIATED PLANS SHOULD BE READ IN CONJUNCTION WITH THE SITE MANAGEMENT SPECIFICATION INCORPORATED IN THE CONTRACT DOCUMENTS. THE PROVISIONS OF THE SPECIFICATION ARE TO BE STRICTLY ADHERED TO.
- THE BASIC OBJECTIVES OF THE EROSION AND SEDIMENT CONTROL ARE:
  - IDENTIFY CRITICAL AREAS AND PROVIDE APPROPRIATE ATTENTION TO THOSE AREAS.
  - PLAN SITE LAYOUTS SO THAT ACCESS TO ALL REQUIRED DRAINAGE EROSION AND SEDIMENT CONTROL MEASURE IS MAINTAINED.
  - LIMIT EXPOSURE TIME BY PROGRAMMING TO MINIMISE THE AREA OF LAND EXPOSED TO POTENTIALLY ADVERSE WEATHER CONDITIONS AT ANY ONE TIME. I.E. PROGRESSIVELY CLEAR AND REVEGETATE.
  - PROVIDE CONTROL MEASURES INCLUDING TEMPORARY AND PERMANENT DRAINAGE, EROSION AND SEDIMENT CONTROLS.
- THE EROSION AND SEDIMENT CONTROL SHALL COMPLY WITH BEST PRACTICE FOR EROSION AND SEDIMENT CONTROL, THE POLLUTION CONTROL MANUAL FOR URBAN STORMWATER MANAGEMENT, THE QUEENSLAND URBAN DRAINAGE MANUAL, AND THE SOIL EROSION AND SEDIMENT CONTROL - ENGINEERING GUIDELINES FOR QUEENSLAND (CURRENT EDITIONS).
- CONSTRUCTION SEQUENCE THE CONSTRUCTION SEQUENCE WILL GENERALLY BE:
  - OBTAIN ALL NECESSARY PERMITS AND APPROVALS BEFORE SITE ESTABLISHMENTS.
  - HOLD A PRE-CONSTRUCTION CONFERENCE.
  - STABILISE ALL CONSTRUCTION ACCESS ROUTES AND ENTRY/EXIT POINTS.
  - ESTABLISH SEDIMENT CONTROL STRUCTURES AND TEMPORARY DRAINAGE CONTROL MEASURES AS NECESSARY.
  - CARRY OUT BULK EARTHWORKS.
  - MAINTAIN AND REPAIR DRAINAGE, EROSION AND SEDIMENT CONTROL MEASURES.
  - REMOVE SEDIMENT CONTROL MEASURES WHEN THE SITE IS STABILISED. I.E. >70% GROUND COVER
  - THE CONTRACTOR SHALL PREPARE A SUPPLEMENTARY EROSION AND SEDIMENT CONTROL PLAN TO SUIT HIS/HER CONSTRUCTION METHODOLOGY, AND SUBMIT THIS PLAN FOR APPROVAL TO THE SUPERINTENDENT. IT SHOULD BE NOTED THAT ANY SIGNIFICANT VARIATION TO THIS PLAN MAY REQUIRE RESUBMISSION TO COUNCIL FOR APPROVAL. THE CLIENT SHALL NOT BE RESPONSIBLE FOR ANY SUCH ASSOCIATED DELAY.
- ALL ESC DEVICES ARE TO BE INSPECTED WEEKLY, PRIOR TO EXPECTED AND AFTER RAINFALL ANY DAMAGE IS TO BE REPAIRED AS REQUIRED TO MAINTAIN THEIR EFFICACY.
- ALL TEMPORARY EROSION AND SEDIMENT CONTROL (ESC) MEASURE TO BE MAINTAINED AND FULLY OPERATIONAL DURING THE MAINTENANCE PERIOD AND ARE TO BE REMOVED AFTER THE SATISFACTORY COMPLETION OF AN OFF-MAINTENANCE INSPECTION BY COUNCIL AND PRIOR TO FORMAL ACCEPTANCE "OFF MAINTENANCE" BY COUNCIL.
- PRIOR TO THE COMMENCEMENT OF CONSTRUCTION, THE CONTRACTOR IS TO PROVIDE A DETAILED PROGRAM TO THE SUPERINTENDENT SHOWING THE TIMING FOR ALL WORKS ASSOCIATED WITH THE PROJECT, NOMINATING, IN PARTICULAR, THE PROGRAM FOR INSTALLATION OF SOIL AND EROSION CONTROL SYSTEMS.
- EARTHWORKS SHALL BE CARRIED OUT IN SUCH A MANNER THAT THE SITE IS MAINTAINED IN A WELL DRAINED CONDITION, AREAS OF LOOSE SOIL ARE MINIMISED AND CONCENTRATIONS OF STORMWATER ARE MINIMISED. BULK EARTHWORKS WILL BE CARRIED OUT OVER THE ENTIRE SITE IN ONE STAGE.
- A SHAKE DOWN AS DETAILED ON THE PLAN COMPRISING FREE DRAINAGE GRAVEL SHALL BE LOCATED ADJACENT TO THE POINT OF ACCESS WHERE VEHICLES CAN BE WASHED DOWN PRIOR TO EXIT TO THE STREET SYSTEM IF REQUIRED. THE WASH DOWN AREA SHALL BE KEPT FREE OF MUD.
- FOR DETAILS OF ENTRY/EXIT SEDIMENT PAD REFER TO BEST PRACTICE EROSION & SEDIMENT CONTROL BOOK 1, PAGE 2.48, FIGURE 2.6.
- SUPPLEMENTARY EROSION AND SEDIMENT CONTROL DEVICES MAY BE REQUIRED AT THE DISCRETION OF THE SUPERINTENDENT.
- SEDIMENTATION FENCES TO BE PLACED AS SHOWN. FOR DETAILS OF SEDIMENT FENCE REFER BEST PRACTICE EROSION & SEDIMENT CONTROL BOOK 1, PAGE 2.50, FIGURE 2.8.
- WHERE SEDIMENT FENCES ARE SHOWN TO BE CONSTRUCTED IN AREAS OF SIGNIFICANT EARTHWORKS, ERECTION OF THE FENCE MAY BE DEFERRED UNTIL COMPLETION OF THE BULK EARTHWORKS, SUBJECT TO ABSENCE OF RAIN.

**TREES**

- ENSURE COMPLIANCE WITH THE REQUIREMENTS OF AS4970 – TREES ON CONSTRUCTION SITES. THIS MAY REQUIRE CONSULTATION AND GUIDANCE FROM A CLASS V CERTIFIED ARBORIST AS TREES OUTSIDE THE IMMEDIATE WORK AREA MAY BE AFFECTED.
- ENSURE COMPLIANCE WITH THE REQUIREMENTS OF THE 28 SOUTH ENVIRONMENTAL FMP, INCLUDING IMPLEMENTING THE NOMINATED TREE PROTECTION ZONES.

**EROSION AND SEDIMENT CONTROL NOTES**

- NO DISTURBED AREA IS TO REMAIN DENUDEED LONGER THAN 60 DAYS.
- ALL EROSION AND SILTATION CONTROL MEASURES ARE TO BE PLACED PRIOR TO OR AS THE FIRST STEP IN CLEARING AND GRUBBING OR ANY OTHER EARTHWORKS OR TRENCHING.
- ALL STORMWATER, SEWER LINE AND SERVICES TRENCHES NOT IN STREETS ARE TO BE MULCHED AND SEEDED WITHIN 15 DAYS AFTER BACKFILL, NO MORE THAN 150 METRES ARE TO BE OPEN AT ANY ONE TIME.
- ALL TEMPORARY EARTH BANKS, DIVERSIONS AND SEDIMENT DAM EMBANKMENTS ARE TO BE MACHINE-COMPACTED, SEEDED AND MULCHED FOR TEMPORARY VEGETATIVE COVER WITHIN 10 DAYS AFTER GRADING. STRAW OR HAY MULCH IS REQUIRED.
- ALL FILL EMBANKMENTS ARE TO BE LEFT WITH A LIP AT THE TOP OF THE SLOPE AT THE END OF EACH DAYS OPERATION.
- ALL CUT AND FILL BATTERS ARE TO BE SEEDED AND MULCHED WITHIN 10 DAYS OF COMPLETION OF GRADING.
- ADDITIONAL SILT AND EROSION CONTROLS MAY BE REQUIRED AS ORDERED ON SITE BY THE SUPERVISING ENGINEER.
- ALL CONTROLS ARE TO BE INSPECTED AFTER EACH STORM EVENT AND MAINTAINED AS REQUIRED. CONTROLS ARE TO BE MAINTAINED UNTIL THE DISTURBED AREAS ARE PERMANENTLY STABILIZED OR UNTIL NO LONGER REQUIRED.

**PHASE 1 - CLEARING AND BULK EARTHWORKS**

CONSTRUCT AND MAINTAIN SILT FENCES, STRAW BALE TRAPS, ALLOTMENT DRAINAGE BANKS, CATCH DRAINS AND HYDROMULCHING WHICH CONTROL SEDIMENT AND EROSION DURING CLEARING AND BULK EARTHWORKS.

**PHASE 2 - TRENCH EXCAVATION**

CONSTRUCT AND MAINTAIN SILT FENCES, STRAW BALE TRAPS, ALLOTMENT DRAINAGE BANKS AND CATCH DRAINS WHICH CONTROL SEDIMENTATION AND EROSION DURING TRENCHING WORK.

**PHASE 3 - PAVEMENT CONSTRUCTION**

CONSTRUCT AND MAINTAIN SILT FENCES, STRAW BALE TRAPS, ALLOTMENT DRAINAGE BANKS, GULLY INLET PROTECTION, AND PIPE INLET/OUTLET PROTECTION WHICH CONTROL SEDIMENTATION AND EROSION DURING PAVEMENT CONSTRUCTION. SAND BAGGING TO BE PLACED ACROSS PAVEMENT TO CONTROL RUNOFF IN PAVEMENT BOXING AS DIRECTED ON SITE.

**PHASE 4 - MAINTENANCE PERIOD**

CONSTRUCT AND MAINTAIN CONTROLS AND VEGETATIVE TREATMENTS WHICH CONTROL SEDIMENTATION AND EROSION PRIOR TO THE ESTABLISHMENT OF GRASS COVER. PROVIDE 600mm WIDE GRASS FILTER STRIPS BEHIND KERB AND CHANNEL.

NOTE: TURF TREATMENT IN CERTAIN AREAS BY LANDSCAPER. REFER TO LANDSCAPE DRAWING.

**NOTE**

ALL VEHICLES EXITING FROM THE SITE ARE TO BE CLEANED AND TREATED TO PREVENT MATERIAL BEING TRACKED OR DEPOSITED ONTO PUBLIC ROADS. IF MATERIAL IS ACCIDENTLY DEPOSITED ONTO PUBLIC ROADS IT SHALL BE REMOVED WITHOUT DELAY. IF THE SHAKEDOWN DEVICE PROVES TO BE INEFFECTIVE THE CONTRACTOR IS TO USE OTHERS MEANS TO PREVENT MATERIAL BEING DEPOSITED ONTO PUBLIC ROADS.

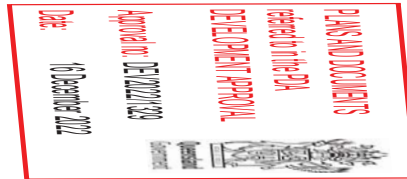

**TOPSOIL**

- STRIP AND STOCKPILE AVAILABLE TOPSOIL (ASSUMED AVERAGE DEPTH 150mm) FROM ALL DISTURBED AREAS PRIOR TO BULK EARTHWORKS. GRADE EVENLY BETWEEN ALLOTMENT FINISHED SURFACE LEVELS AND ENSURE LOTS ARE FREE DRAINING.
- MINIMUM SLOPE ACROSS ALLOTMENTS TO BE 1%.
- ALL FOOTPATHS, BATTERS, AND EARTHWORKS AFFECTED ALLOTMENTS ARE TO BE TOPSOILED TO A MINIMUM DEPTH OF 150mm (LIGHTLY COMPACTED) AND TURFED WHERE SPECIFIED.

**SEDIMENT FENCES**

- SEDIMENT FENCES TO BE PLACED AS SHOWN. SEDIMENT FENCED TO BE REPAIRED AND EXCESSIVE SEDIMENT DEPOSITS SHALL BE REMOVED ONCE CAPACITY FALLS BELOW 75%.
- FOR DETAILS OF SEDIMENT FENCE REFER BEST PRACTICE EROSION & SEDIMENT CONTROL BOOK 1, PAGE 2.50, FIGURE 2.8.
- SEDIMENT FENCES TO BE REPAIRED AS REQUIRED AND EXCESSIVE SEDIMENT DEPOSITS SHOULD BE REMOVED.
- INSTALL KERB INLETS WITH GRAVEL RANGING FROM 50mm TO 75mm IN SIZE SHALL BE INSTALLED AT ALL COMPLETED INLETS. REFER IPWEAQ STANDARD DRAWING D-004.1. THESE SHALL BE MAINTAINED IN A CLEAN CONDITION. IN THE EVENT OF HEAVY RAIN THEY SHALL BE REMOVED TO MINIMISE THE POTENTIAL FOR FLOODING.
- CHECKS OF SILT CONTROL DEVICES ARE TO BE MADE WEEKLY, OR AFTER ANY SIGNIFICANT STORM EVENT TO ENSURE INTEGRITY AND PERFORMANCE.

**TURFING**

- PROVIDE TURFING TO ENTIRE WIDTH OF ALL SWALES, FOOTPATHS AND 1 IN 4 CUT AND FILL BATTERS.
- FOOTPATH BATTERS ARE TO BE STABILISED WITH TOPSOIL (AND TURFED) AS SOON AS PRACTICAL AFTER THE BATTERS HAVE BEEN COMPLETED.

**DURING CONSTRUCTION SEQUENCE:**

- TOPSOIL STOCKPILES SHALL BE LESS THAN 1m DEEP AND UNCOMPACTED. A SEDIMENTATION FENCE SHALL BE CONSTRUCTED ON THE D/S SIDE, OR THE STOCKPILE STABILISED WITH VEGETATION, MULCH, OR A SOIL STABILISER.
- SEDIMENTATION FENCES TO BE PLACED AS SHOWN.
- REGULARLY INSPECT BANKS AND REPAIR ANY SLUMPS, WHEEL TRACK DAMAGE OR LOSS OF FREEBOARD.
- REMOVE SEDIMENT TO AVOID PONDING FROM CATCH DRAINS.
- REMOVE EXCESSIVE SEDIMENT FROM UPSTREAM OF CHECK DAM.
- ROAD RESERVE TO BE USED AS HAUL ROAD.
- A CATCH DRAIN OR DIVERSION BANK IS TO BE PROVIDED ON THE TOP SIDE OF ALL CUTS, WITH DISCHARGE EITHER TO UNDISTURBED GRASS LANDS OR TO THE CROSS ROAD DRAINAGE.
- SUPPLEMENTARY EROSION AND SEDIMENT CONTROL DEVICES MAY BE REQUIRED AT THE DISCRETION OF THE ENGINEER.
- WATER QUALITY SAMPLES MUST BE TAKEN AND ANALYSED PRIOR TO THE RELEASE OF ANY WATER FROM THE SEDIMENT POND. WATER QUALITY MUST SATISFY THE FOLLOWING CRITERIA- TSS-<50MG/L PH BETWEEN 6.5 AND 8.5.
- ALL WATER QUALITY DATA INCLUDING DATES OF RAINFALL, TESTING AND WATER RELEASE MUST BE MAINTAINED IN AN ON-SITE REGISTER. THIS REGISTER IS TO BE MAINTAINED FOR THE DURATION OF THE APPROVED WORKS AND BE AVAILABLE ON SITE FOR INSPECTION BY COUNCIL OFFICERS ON REQUEST.
- EXPOSED AREAS ON LOTS ARE TO BE SEEDED AND MULCHED (E.G. HYDROMULCHED). MULCH SHALL BE APPLIED AT A MINIMUM RATE OF 2.5T/HA. ALTERNATIVELY THEY SHALL BE DRILL-SEEDED AND IRRIGATED SO AS TO ENSURE >70% GROUND COVER WITHIN 14 DAYS FROM NOVEMBER TO APRIL, OR 30 DAYS FROM MAY TO OCTOBER.

**FOLLOWING CONSTRUCTION:**

- SEDIMENTATION FENCES TO BE MAINTAINED UNTIL TURFING IS COMPLETED.
- SEDIMENT BASINS TO BE CHECKED AFTER EVERY SIGNIFICANT STORM AND DESILTED ONCE THE SETTLEMENT LIMIT HAS BEEN REACHED.

**STABILISATION:**

- THE AMOUNT OF AREA EXPOSED AT ANY ONE TIME TO BE MINIMISED BY STAGING THE WORKS WHEREVER POSSIBLE AND AIMING TO ACHIEVE FINISHED LEVEL IN EACH AREA AS QUICKLY AS POSSIBLE BEFORE OPENING NEW AREAS.
- TOPSOIL TO BE STRIPPED AND STOCKPILED SEPARATELY TO SUB-SOILS.
- STOCKPILES TO BE PROVIDED WITH SURFACE COVER USING A CHEMICAL SURFACE STABILISER SUCH AS VITAL CHEMICALS VITAL-BON MATT STONEWALL.
- IF WORKS ARE DELAYED OR PUT ON HOLD THEN TEMPORARY EROSION CONTROL COVERING TO BE PROVIDED USING VITAL CHEMICALS VITAL-BON MATT P47-VR1 OR EQUIVALENT.
- ONCE AREAS REACH FINISHED LEVEL:
  - TOPSOIL TO BE SPREAD TO CAP/BURY THE DISPERSIVE SUBSOILS.
  - TOPSOIL TO BE DRILL-SEEDED WITH A MIXTURE OF ANNUAL AND PERENIAL GRASS SPECIES (REFER TABLE) AND FERTILISER WITH CROP-KING 88 (0.3t/ha).
  - TEMPORARY SOIL COVER TO BE APPLIED CONSISTING OF VITAL CHEMICALS VITAL-BON MATT P47-VR1 OR EQUIVALENT.
  - WATERING UNDERTAKEN AS NECESSARY UNTIL STABLE GRASS SURFACE COVER IS ESTABLISHED.

|  | SEED MIXES                                      |   |  |
|--|---|---|--|
|  | SUMMER BLEND (APPLICATIONS NOVEMBER - DECEMBER) | MID SEASON BLEND (APPLICATIONS MARCH/APRIL & SEPTEMBER/OCTOBER) | WINTER BLEND (APPLICATIONS MAY AUGUST) |
| UNHULLED GREEN COUCH (CYNODON DACTYLONI OR BLUE COACH (DIGITARIA DIACYLIA) | 25%   | 25%   | 25%                                    |
| HULLED GREEN COUCH (CYNODON DACTYLONI OR BLUE COACH (DIGITARIA DIACYLIA)   | 25%   | 25%   | 25%                                    |
| JAPANESE MILLET  | 30%   | 15%   | N/A                                    |
| RYE GRASS  | N/A   | 15%   | 30%                                    |
| CARPET GRASS (AXONOPUS AFFINIS)  | 20%   | 20%   | 20%                                    |

DO NOT SCALE THIS DRAWING IF IN DOUBT - ASK!

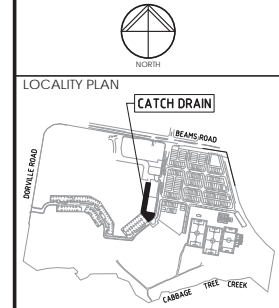

**REVISIONS**

| No | Description  | Date       | By |
|----|--------------|------------|----|
| A  | FOR APPROVAL | 27.07.2022 | AA |
|    |              |            |    |
|    |              |            |    |
|    |              |            |    |
|    |              |            |    |
|    |              |            |    |
|    |              |            |    |
|    |              |            |    |
|    |              |            |    |
|    |              |            |    |
|    |              |            |    |

**ECONOMIC DEVELOPMENT QUEENSLAND (EDQ)**

**CARSELDINE VILLAGE CATCH DRAIN**

Approved: **M. Shaw** Mark Andrew Shaw (Eng (Civil), MIE Aust, RPEQ 17544 2022.07.27 13:34:32 +10'00')

Drawing title: **EROSION AND SEDIMENT CONTOUR PLAN NOTES**

|                 |                 |             |               |
|-----------------|-----------------|-------------|---------------|
| Drawn: RW       | Designed: JB    | Checked: MS | Date: JUL '22 |
| Scale: AS SHOWN | Sheet: 10 of 12 |             | Revision:     |
| A1              | 22-106-10       | A           |               |

DO NOT SCALE THIS DRAWING  
IF IN DOUBT - ASK!



### LOCALITY PLAN

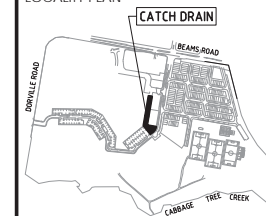

### REVISIONS

| No | Description  | Date       | By |
|----|--------------|------------|----|
| A  | FOR APPROVAL | 27.07.2022 | AA |
|    |              |            |    |
|    |              |            |    |
|    |              |            |    |
|    |              |            |    |
|    |              |            |    |
|    |              |            |    |
|    |              |            |    |
|    |              |            |    |
|    |              |            |    |

## ECONOMIC DEVELOPMENT QUEENSLAND (EDQ)

### CARSELDINE VILLAGE CATCH DRAIN



Approved  
*M. Shaw* Mark Andrew Shaw BEng (Civil), MIEAust, RPEQ 17544  
2022.07.27 13:34:48 +1'00'

### EROSION AND SEDIMENT CONTOUR PLAN DETAILS

| Drawn      | Designed  | Checked | Date     |
|------------|-----------|---------|----------|
| RW         | JB        | MS      | JUL '22  |
| Scale      | Sheet     |         | Revision |
| AS SHOWN   | 11 of 12  |         |          |
| Drawing No | Revision  |         |          |
| A1         | 22-106-11 |         | A        |

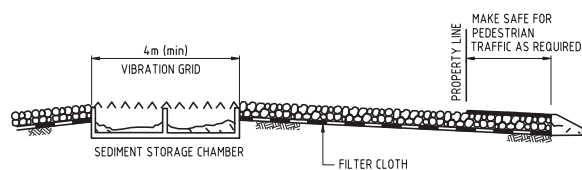

#### TYPICAL PROFILE OF A VIBRATION GRID SITE ACCESS POINT SHAKEDOWN FACILITY N.T.S.

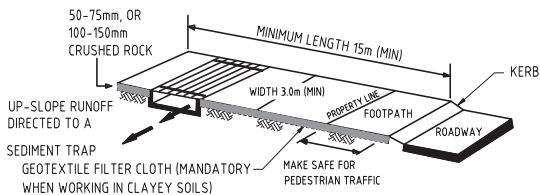

#### SITE ACCESS POINT ENTRY/EXIT PAD N.T.S.

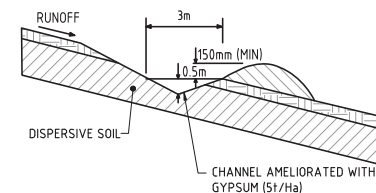

### CATCH DRAIN

| OPEN EARTH SLOPES |        |       |       |        |       | VEGETATED SLOPES |               |       |  |
|-------------------|--------|-------|-------|--------|-------|------------------|---------------|-------|--|
| SLOPE             | HORIZ. | VERT. | SLOPE | HORIZ. | VERT. | SLOPE            | HORIZ.        | VERT. |  |
| 1%                | 80m    | 0.9m  | 15%   | 19m    | 2.9m  | -10%             | NO MAXIMUM    |       |  |
| 2%                | 60m    | 1.2m  | 20%   | 16m    | 3.2m  | 12%              | 100m          | 12m   |  |
| 4%                | 40m    | 1.6m  | 25%   | 14m    | 3.5m  | 15%              | 80m           | 12m   |  |
| 6%                | 32m    | 1.9m  | 30%   | 12m    | 3.5m  | 20%              | 55m           | 11m   |  |
| 8%                | 28m    | 2.2m  | 35%   | 10m    | 3.5m  | 25%              | 40m           | 10m   |  |
| 10%               | 25m    | 2.5m  | 40%   | 9m     | 3.5m  | 30%              | 30m           | 9m    |  |
| 12%               | 22m    | 2.6m  | 50%   | 6m     | 3.0m  | +36%             | CASE SPECIFIC |       |  |

TYPICAL CATCH DRAINS DIMENSIONS & SPACINGS

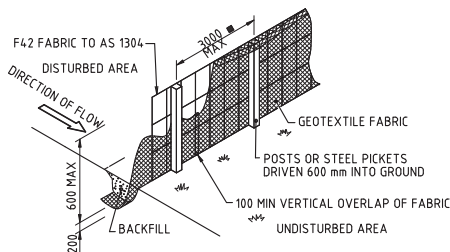

#### SEDIMENT FENCE N.T.S.

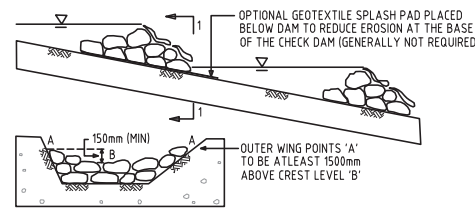

#### CHECK DAM N.T.S.

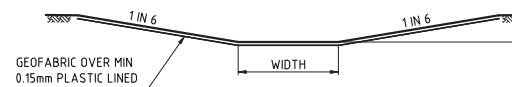

### TYPICAL LINED CATCH DRAIN

SCALE 1:40

SIZING TO BE DETERMINED DURING CONSTRUCTION

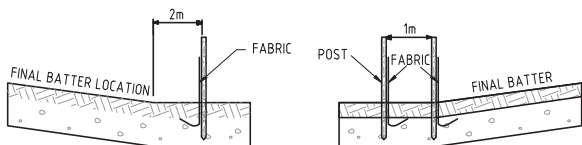

a) PLACEMENT OF SEDIMENT FENCE AT BASE OF FILL SLOPE  
b) USE OF DOUBLE SEDIMENT FENCE AT THE BASE OF FILL SLOPE

### SEDIMENT FENCE DETAILS N.T.S.

LOCATION OF SEDIMENT FENCE AT BASE OF FILL SLOPE

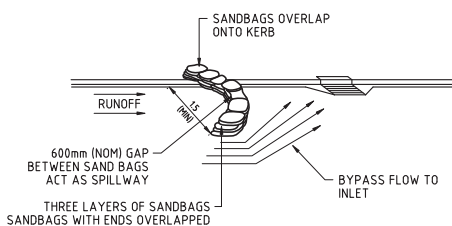

#### ON GRADE GULLY INLET N.T.S.

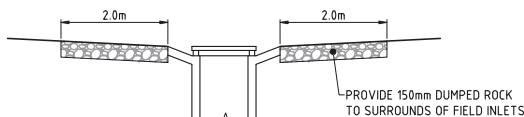

#### FIELD INLET PROTECTION N.T.S.

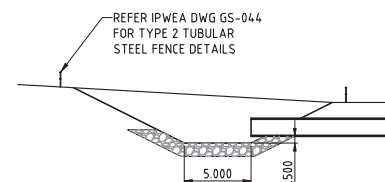

#### TEMPORARY HEADWALL DETAIL SCALE N.T.S.

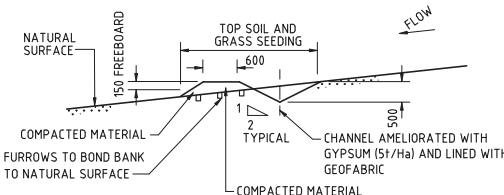

#### CROSS SECTION DIVERSION CHANNEL N.T.S.

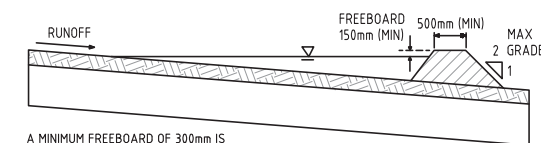

A MINIMUM FREEBOARD OF 300mm IS RECOMMENDED FOR NON-VEGETATED EARTH EMBANKMENTS

#### DIVERSION DRAINAGE BANK N.T.S.



LOCALITY PLAN

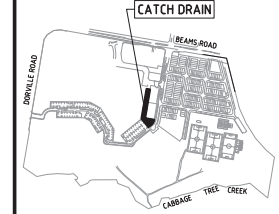

REVISIONS

| No | Description  | Date       | By |
|----|--------------|------------|----|
| A  | FOR APPROVAL | 27.07.2022 | AA |
|    |              |            |    |
|    |              |            |    |
|    |              |            |    |
|    |              |            |    |
|    |              |            |    |
|    |              |            |    |
|    |              |            |    |
|    |              |            |    |
|    |              |            |    |
|    |              |            |    |
|    |              |            |    |
|    |              |            |    |
|    |              |            |    |

Client: ECONOMIC DEVELOPMENT QUEENSLAND (EDQ)  
 Project: CARSELDINE VILLAGE – CATCH DRAIN  
 Prepared By: Jason Burton Date: 10<sup>th</sup> June 2022  
 Reviewed By: Mark Shaw Date: 10<sup>th</sup> June 2022

Safety in Design Analysis

- Complete Safety in Design Analysis by populating the table where applicable with all of the relevant safety issues for the project. For example:

|  |   |
|--|---|
| <input type="checkbox"/> Positioning of new services adjacent to existing live services        | <input checked="" type="checkbox"/> Slope Stability                         |
| <input checked="" type="checkbox"/> Construction adjacent to existing road carriageways        | <input type="checkbox"/> Retaining Walls                                    |
| <input type="checkbox"/> Pedestrians   | <input checked="" type="checkbox"/> Dust Control                            |
| <input checked="" type="checkbox"/> Civil Construction Workers                                 | <input checked="" type="checkbox"/> Erosion and Sediment Control/Management |
| <input checked="" type="checkbox"/> Maintenance Workers  | <input checked="" type="checkbox"/> Sediment Basin Construction             |
| <input checked="" type="checkbox"/> Work Place Health and Safety Constraints                   | <input type="checkbox"/> Wetland/Dam Construction                           |
| <input type="checkbox"/> Unusual material handling   | <input type="checkbox"/> Working under traffic                              |
| <input type="checkbox"/> Falls from heights  |   |
| <input checked="" type="checkbox"/> Underground Services (existing)                            | Project Specific Design Elements:   |
| <input type="checkbox"/> Electrical Service Installation                                       |   |
| <input type="checkbox"/> Gas Service Installation  |   |
| <input type="checkbox"/> Communication Installation  |   |
| <input type="checkbox"/> Traffic Signal Installation   |   |
| <input checked="" type="checkbox"/> Landscape Workers  |   |
| <input type="checkbox"/> Line marking Workers  |   |
| <input checked="" type="checkbox"/> Excavation – open cut trenching - Trench excavation depths |   |
| <input type="checkbox"/> Tunnel Boring   |   |
| <input checked="" type="checkbox"/> Confined Spaces  |   |
| <input checked="" type="checkbox"/> Lifting of loads   |   |
| <input checked="" type="checkbox"/> Unloading of materials and storage                         |   |
| <input type="checkbox"/> Storage of hazardous materials  |   |
| <input checked="" type="checkbox"/> Geotechnical investigation – works                         |   |
| <input checked="" type="checkbox"/> Bulk Earthworks  |   |
| <input checked="" type="checkbox"/> List all relevant safety studies                           |   |

| Section of Works                            | Identify any Potential Incident or Hazard  | Consequence | Likelihood | Risk Rating | Risk Control Measures  | Consequence | Likelihood | Residual Risk Rating (after design applied) | Risk Manager         |
|---|--|-------------|------------|-------------|--|-------------|------------|---|----------------------|
| Earthworks Material Investigation           | Geotechnical Investigation   | C           | 3          | S           | SWMS required by Contractor  | D           | 3          | M   | Contractor           |
| Road/Earthworks Works                       | Pedestrians Injury   | D           | 3          | M           | TMP to be provided by Contractor to exclude pedestrians from work site.  | E           | 3          | L   | Contractor           |
|   | Civil Construction Workers – Injury  | A           | 4          | H           | TMP and SWMS required for all activities   | C           | 2          | S   | Contractor           |
|   | Maintenance Workers  | A           | 4          | H           | TMP and SWMS required for all activities   | C           | 3          | S   | Contractor           |
|   | Underground Services (Existing)  | A           | 3          | H           | DBID information to be sent prior to design. Existing to be located by survey if applicable to design. All existing services to be located and depths confirmed prior to commencement. SWMS to be provided by Contractor | C           | 2          | S   | Designer/ Contractor |
| Working adjacent to existing infrastructure | Conflict between construction equipment / personnel and live infrastructure in particular Power lines          | B           | 4          | S           | All existing services highlighted in the documentation. Contractor to complete DBVD search before commencing works. SWMS to be provided by Contractor  | C           | 4          | M   | Designer/ Contractor |
| Service trench/ pipe installation           | Location of all trenches to provide clearance to all other services and all structures or battered embankments | A           | 4          | H           | Mains located with safe working clearance to existing pressure mains, structures and battered embankments  | C           | 4          | M   | Designer             |
|   | Trench depth   | A           | 4          | M           | Depth of trenches minimized for both safety and cost efficiency  | C           | 4          | M   | Designer             |
| Works within Confined Spaces                | Construction of stormwater, sewer, water and wetland structures  | A           | 4          | M           | Contractor to ensure works undertaken in a manner complying with safe work method statements   | D           | 5          | L   | Contractor           |
| Silt and Erosion Control                    | Public access to water retaining temporary sediment basins   | A           | 5          | S           | Protection measures – that is fencing of all water retaining structures with side slopes greater than 1 in 5 as described in International Erosion Control Association (Australasian) Table B9                           | C           | 4          | M   | Designer/ Contractor |

The following table summarises the safety in design issues considered.

RISK ASSESSMENT AND CONTROL

| Risk Assessment  |   |            |               |
|--|---|------------|---------------|
| Select <b>one</b> category from each of the columns below that best represents the likely outcome if the potential hazard actually did occur. For each consequence consider the <b>most likely outcome</b> and <b>not</b> the 'absolute worst' case. |   |            |               |
| Consequence  |   | Likelihood |               |
| A  | Death – major environmental damage                    | 1          | Certain       |
| B  | Permanent Disability – severe environmental damage    | 2          | Probable      |
| C  | Lost Time Injury – moderate environmental damage      | 3          | Possible      |
| D  | Medical Treatment Injury – minor environmental damage | 4          | Unlikely      |
| E  | First Aid Treatment                                   | 5          | Very Unlikely |

RISK RATING

**Certain** - means an event or situation that is happening more or less all the time, including continuous situations  
**Permanent Disability** – means a disability, such as loss of a limb or eyesight, loss of hearing, chronic skin disorder, chronic back disorder, emphysema, and the like

H: High Risk                      S: Significant Risk  
 M: Moderate Risk              L: Low Risk

Read the Risk Rating from the matrix below:

| Risk Assessment Matrix | A | B | C | D | E |
|------------------------|---|---|---|---|---|
| 1                      | H | H | H | S | S |
| 2                      | H | H | S | S | M |
| 3                      | H | H | S | M | L |
| 4                      | H | S | M | L | L |
| 5                      | S | S | M | L | L |

**Probable** – means an event or situation that occurs or is likely to occur about ten times or more per year  
**Possible** – means an event or situation that occurs or is likely to occur about once per year  
**Unlikely** – means an event or situation that occurs or is likely to occur less frequently than once every ten years

Issued 10<sup>th</sup> June 2022 Rev - A



Page | 1

Client  
ECONOMIC DEVELOPMENT QUEENSLAND (EDQ)

Project  
CARSELDINE VILLAGE CATCH DRAIN



Approved  
 M. Shaw Mark Andrew Shaw BEng (Civil), MIEAust, RPEQ 17544 2022.07.27 13:34:57 +10'00'

|                                   |                         |                   |                 |
|-----------------------------------|-------------------------|-------------------|-----------------|
| Drawing title<br>SAFETY IN DESIGN |                         |                   |                 |
| Drawn<br>RW                       | Designed<br>JB          | Checked<br>MS     | Date<br>JUL '22 |
| Scale<br>AS SHOWN                 |                         | Sheet<br>12 of 12 |                 |
| A1                                | Drawing No<br>22-106-12 | Revision<br>A     |                 |



# CARSELDINE VILLAGE CATCH DRAIN

**PLANS DOCUMENTS**  
 referred to in the PDA  
 DEVELOPMENT APPROVAL  
 APPROVED ON 12/02/2022  
 Date: 10 December 2022

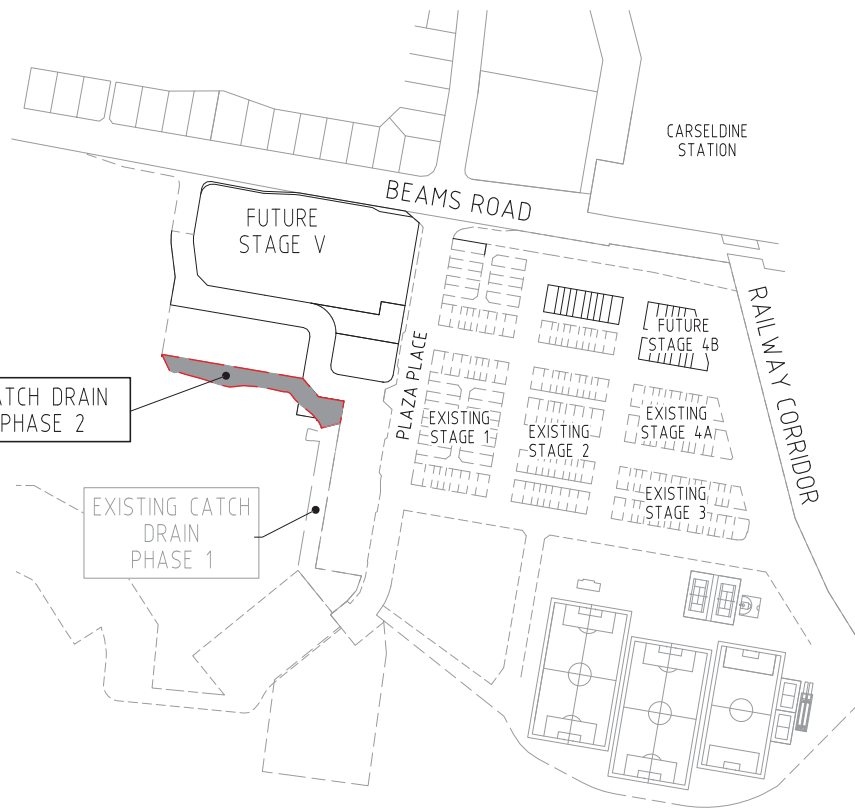

PLAN  
SCALE 1:2000

### DRAWING INDEX

| DRAWING NO. | DRAWING TITLE                                       |
|-------------|---|
| 22-106-101  | GENERAL - LOCALITY PLAN, DRAWING INDEX AND NOTES    |
| 22-106-102  | GENERAL - SETOUT PLAN                               |
| 22-106-103  | GENERAL - LAYOUT PLAN                               |
| 22-106-104  | EARTHWORKS - CONTOUR PLAN                           |
| 22-106-105  | CATCH DRAIN - CROSS SECTIONS EXISTING PHASE 1 WORKS |
| 22-106-106  | CATCH DRAIN - CROSS SECTIONS PROPOSED PHASE 2 WORKS |
| 22-106-107  | EROSION AND SEDIMENT - CONTOUR PLAN LAYOUT PLAN     |
| 22-106-108  | EROSION AND SEDIMENT - CONTOUR PLAN NOTES           |
| 22-106-109  | EROSION AND SEDIMENT - CONTOUR PLAN DETAILS         |
| 22-106-110  | SAFETY IN DESIGN                                    |

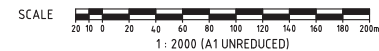

DO NOT SCALE THIS DRAWING  
IF IN DOUBT - ASK!



LOCALITY PLAN

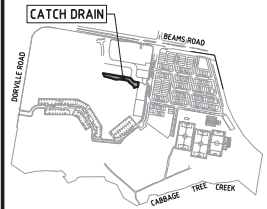

REVISIONS

| No | Description  | Date     | By |
|----|--------------|----------|----|
| A  | FOR APPROVAL | 27.07.22 | AA |
|    |              |          |    |
|    |              |          |    |
|    |              |          |    |
|    |              |          |    |
|    |              |          |    |
|    |              |          |    |
|    |              |          |    |
|    |              |          |    |

Client  
**ECONOMIC  
DEVELOPMENT  
QUEENSLAND (EDQ)**

Project  
**CARSELDINE VILLAGE  
CATCH DRAIN  
PHASE 2**



Approved  
*M. Shaw* Mark Andrew Shaw BEng  
(Civil), MIEAust, RPEQ 17544  
2022.07.27 13:35:09 +10'00'

Drawing title  
**GENERAL  
LOCALITY PLAN,  
DRAWING INDEX AND NOTES**

| Drawn      | Designed   | Checked | Date    |
|------------|------------|---------|---------|
| DES        | JB         | MS      | JUL '22 |
| Scale      | Sheet      |         |         |
| AS SHOWN   | 01 of 10   |         |         |
| Drawing No | Revision   |         |         |
| A1         | 22-106-101 | A       |         |

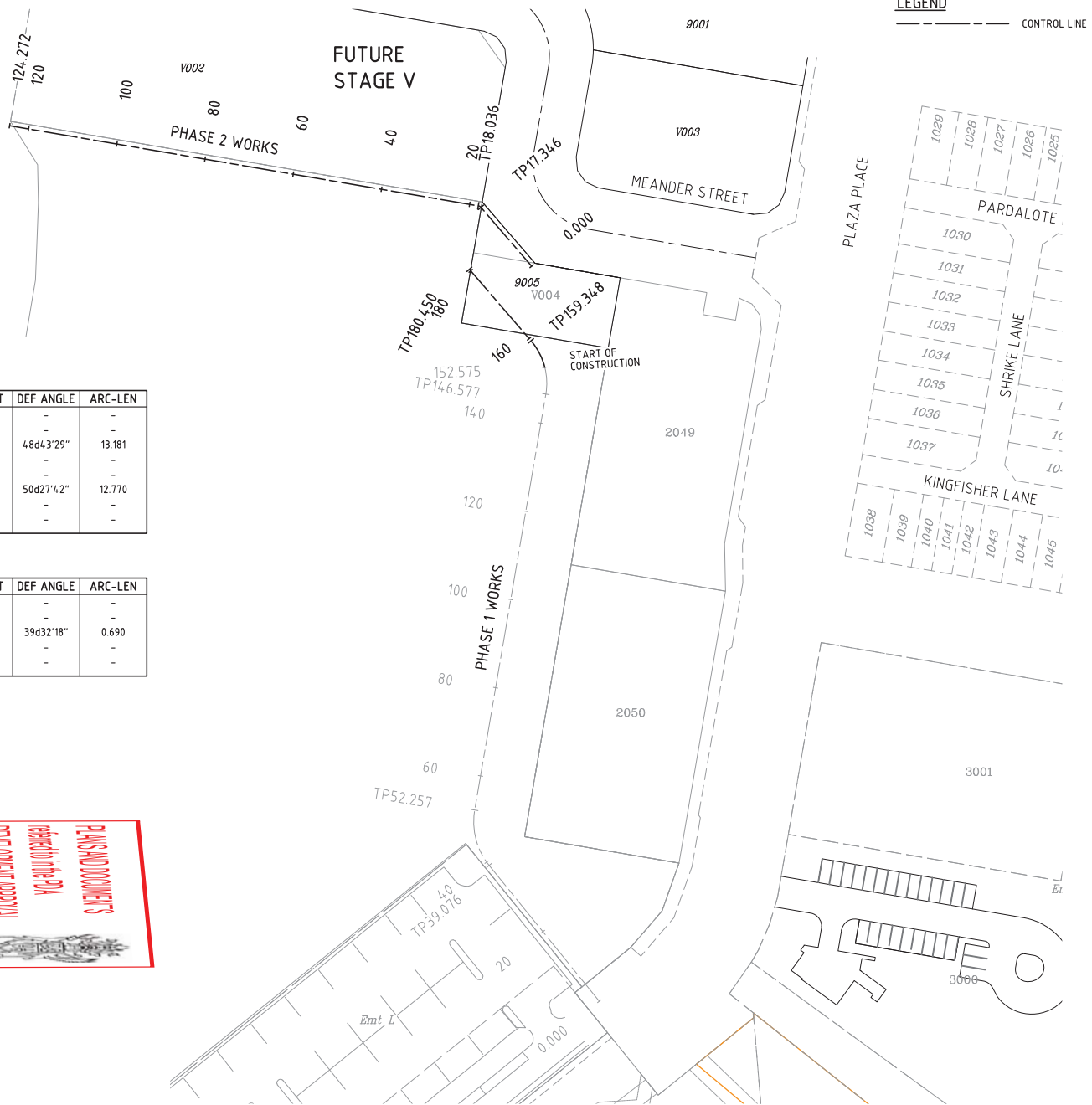

**LEGEND**  
 - - - - - CONTROL LINE

**CATCH DRAIN CONTROL LINE DETAILS**

| PT  | CHAINAGE | EASTING    | NORTHING    | BEARING    | RADIUS | TANGENT | DEF ANGLE | ARC-LEN |
|-----|----------|------------|-------------|------------|--------|---------|-----------|---------|
| IP1 | 0.000    | 502587.596 | 6974671.368 | 320d58'50" | -      | -       | -         | -       |
| TC  | 39.076   | 502562.994 | 6974701.727 | 320d58'50" | -      | -       | -         | -       |
| IP2 | 45.666   | 502558.575 | 6974707.181 | -          | 15.500 | 7.019   | 48d43'29" | 13.181  |
| CT  | 52.257   | 502559.759 | 6974714.099 | 9d42'19"   | -      | -       | -         | -       |
| TC  | 146.577  | 502575.659 | 6974807.069 | 9d42'19"   | -      | -       | -         | -       |
| IP3 | 152.963  | 502576.811 | 6974813.804 | -          | 14.500 | 6.833   | 50d27'42" | 12.770  |
| CT  | 159.348  | 502572.351 | 6974818.980 | 319d14'38" | -      | -       | -         | -       |
| IP4 | 180.451  | 502558.574 | 6974834.965 | 319d14'38" | -      | -       | -         | -       |

**PHASE 2 WORKS CONTROL LINE DETAILS**

| PT  | CHAINAGE | EASTING    | NORTHING    | BEARING    | RADIUS | TANGENT | DEF ANGLE | ARC-LEN |
|-----|----------|------------|-------------|------------|--------|---------|-----------|---------|
| IP1 | 0.000    | 502572.482 | 6974835.677 | 319d14'38" | -      | -       | -         | -       |
| TC  | 17.346   | 502561.157 | 6974848.817 | 319d14'38" | -      | -       | -         | -       |
| IP2 | 17.691   | 502560.923 | 6974849.089 | -          | 1.000  | 0.359   | 39d32'18" | 0.690   |
| CT  | 18.036   | 502560.569 | 6974849.150 | 279d42'19" | -      | -       | -         | -       |
| IP3 | 124.272  | 502455.853 | 6974867.059 | 279d42'19" | -      | -       | -         | -       |

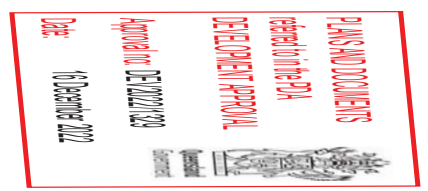

**SETOUT PLAN**  
SCALE 1:500



DO NOT SCALE THIS DRAWING IF IN DOUBT - ASK!

**LOCALITY PLAN**  
 CATCH DRAIN  
 BEANS ROAD  
 CARBAGE TREE CREEK

**REVISIONS**

| No | Description  | Date     | By |
|----|--------------|----------|----|
| A  | FOR APPROVAL | 25.07.22 | AA |

Client: ECONOMIC DEVELOPMENT QUEENSLAND (EDQ)

Project: CARSELDINE VILLAGE CATCH DRAIN PHASE 2

**kn group**  
 ABN 35 112 53 611  
 11 62 Astor Tce  
 Spring Hill Q 4000  
 07 3017 1900  
 www.knigroup.com.au

Approved: *M. Shaw* Mark Andrew Shaw BEng (Civil), MIEAust, RPEQ 17544 2022.07.27 13:35:19 +10'00'









Drawing title: GENERAL SETOUT PLAN

| Drawn | Designed | Checked | Date    |
|-------|----------|---------|---------|
| DES   | JB       | MS      | JUL '22 |

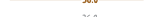
| Scale    | Sheet    |
|----------|----------|
| AS SHOWN | 02 of 10 |

| Drawing No | Revision |
|------------|----------|
| A1         | A        |

**LEGEND**

-  EXISTING EXTENT OF WORKS PHASE 1
-  EXTENT OF WORKS PHASE 2
-  CONTROL LINE
-  FINISHED SURFACE CONTOURS
-  EXISTING SURFACE CONTOURS
-  BATTER LINE
-  EXISTING SURVEYED EDGE OF VEGETATION TRUNK OF TREE LINE
-  EXISTING PHASE 1 4m WIDE GRAVEL ACCESS TRACK
-  4m WIDE GRAVEL ACCESS TRACK

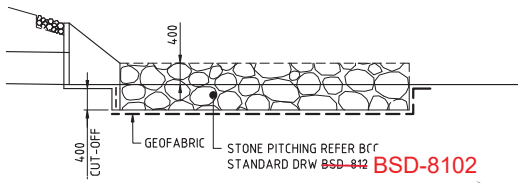
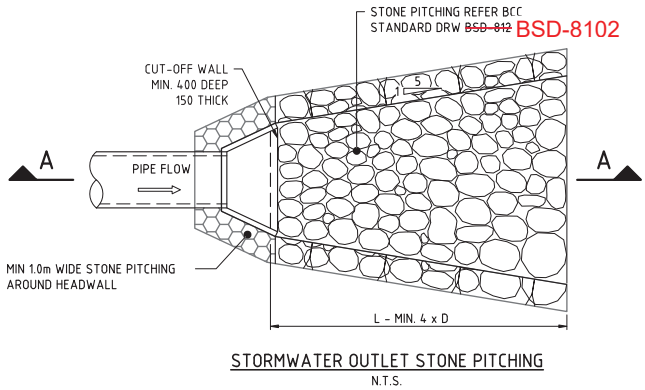
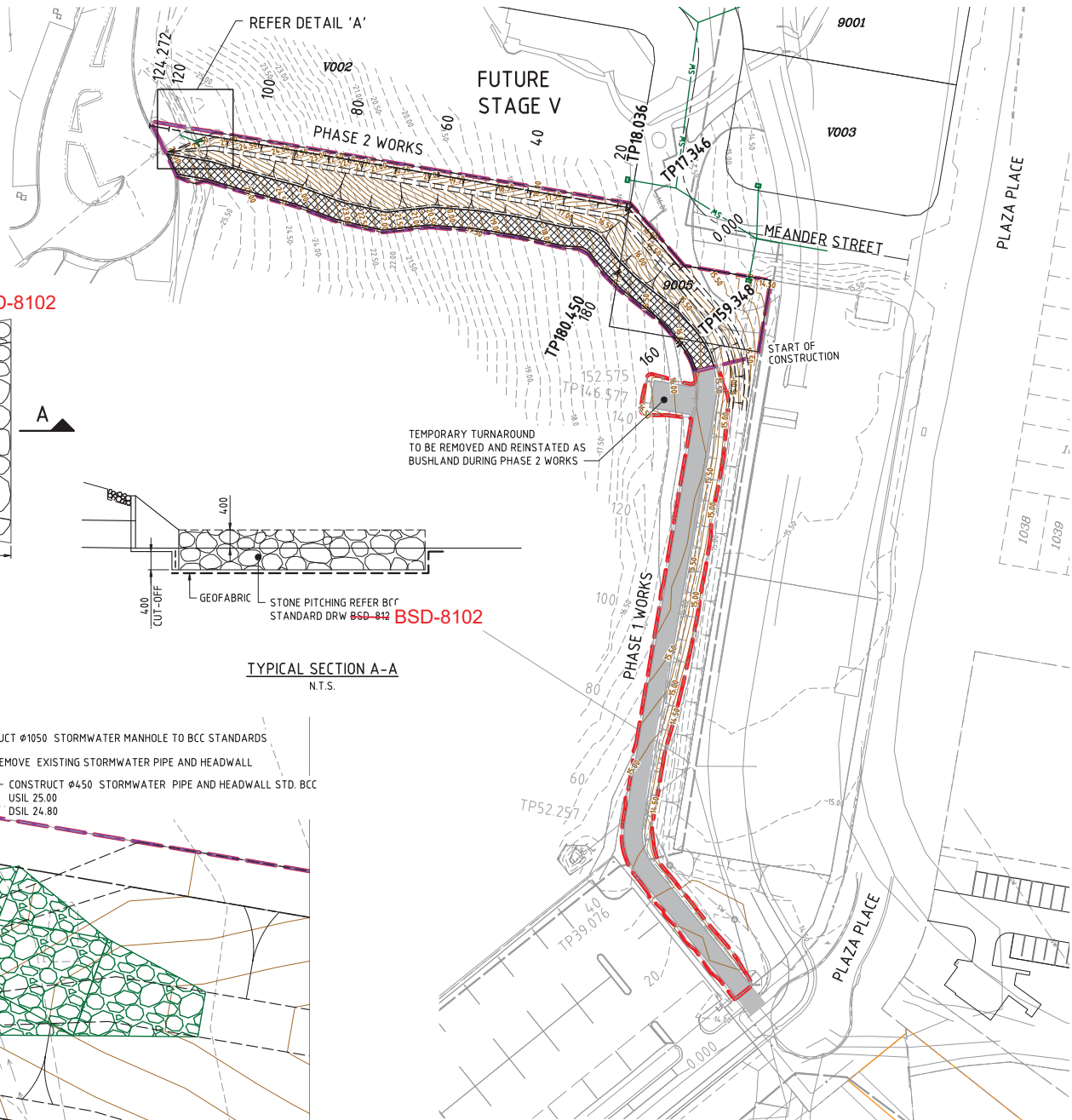

TYPICAL SECTION A-A  
N.T.S.

**PLANS AND DOCUMENTS**  
 Approved by the PA  
 DEVELOPMENT APPROVAL  
 Date: 10 December 2022

- CONSTRUCT Ø1050 STORMWATER MANHOLE TO BCC STANDARDS
- REMOVE EXISTING STORMWATER PIPE AND HEADWALL
- CONSTRUCT Ø450 STORMWATER PIPE AND HEADWALL STD. BCC USIL 25.00 DSIL 24.80

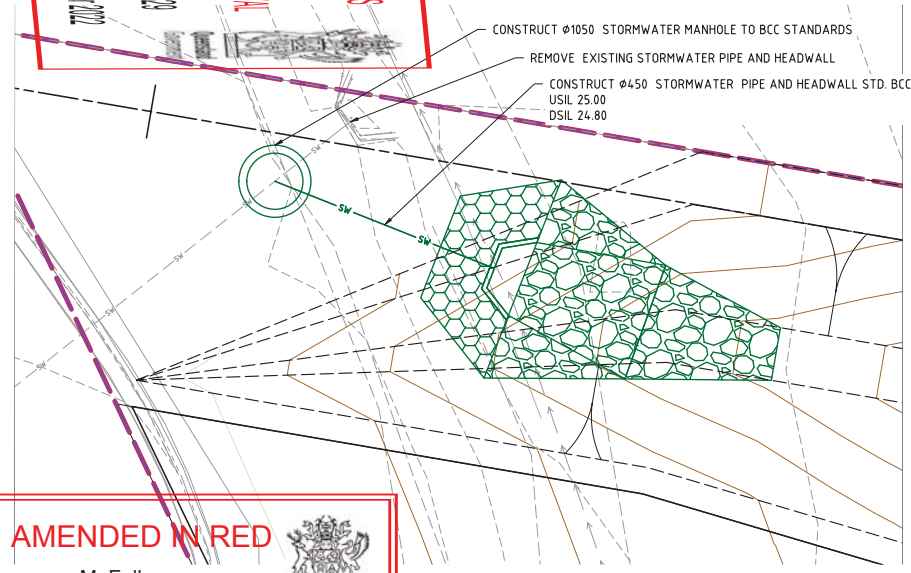

**AMENDED IN RED**  
 By: M. Fallon  
 Date: 7 December 2022  

DETAIL 'A'  
SCALE 1:50

LAYOUT PLAN  
SCALE 1:500

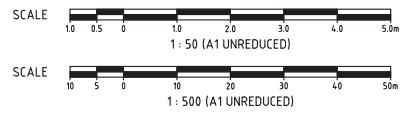

DO NOT SCALE THIS DRAWING IF IN DOUBT - ASK!

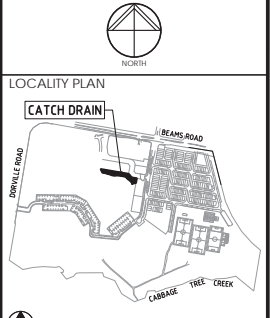

REVISIONS

| No | Description  | Date     | By |
|----|--------------|----------|----|
| A  | FOR APPROVAL | 25.07.22 | AA |

Client  
**ECONOMIC DEVELOPMENT QUEENSLAND (EDQ)**

Project  
**CARSELDINE VILLAGE CATCH DRAIN PHASE 2**



Approved  
*M. Shaw* Mark Andrew Shaw BEng (Civil), MIEAust, RPEQ 17544  
2022.07.27 13:35:28 +10'00'

Drawing title  
**GENERAL LAYOUT PLAN**

|                   |                   |               |                 |
|-------------------|-------------------|---------------|-----------------|
| Drawn<br>DES      | Designed<br>JB    | Checked<br>MS | Date<br>JUL '22 |
| Scale<br>AS SHOWN | Sheet<br>03 of 10 |               | Revision        |
| A1                | 22-106-103        | A             |                 |

P:\3202\22106 Carlseldine Village Catch Drain\ACAD\103 Series\22-106-103-DE-LAYOUT.dwg Plotfile by: AA on: 27/07/2022 11:59:45 AM

DO NOT SCALE THIS DRAWING  
IF IN DOUBT - ASK!



LOCALITY PLAN

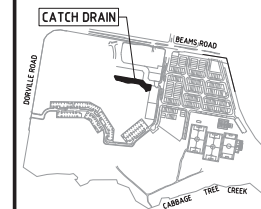

REVISIONS

| No | Description  | Date     | By |
|----|--------------|----------|----|
| A  | FOR APPROVAL | 25.07.22 | AA |
|    |              |          |    |
|    |              |          |    |
|    |              |          |    |
|    |              |          |    |
|    |              |          |    |
|    |              |          |    |
|    |              |          |    |
|    |              |          |    |

Client  
**ECONOMIC DEVELOPMENT QUEENSLAND (EDQ)**

Project  
**CARSELDINE VILLAGE CATCH DRAIN PHASE 2**



Approved  
*M. Shaw* Mark Andrew Shaw BEng (Civil), MIE Aust, RPEQ 17544  
2022.07.27 13:35:40 +10'00'

Drawing title  
**EARTHWORKS CONTOUR PLAN**

| Drawn      | Designed   | Checked | Date           |
|------------|------------|---------|----------------|
| DES        | JB         | MS      | JUL '22        |
| Scale      | AS SHOWN   |         | Sheet 04 of 10 |
| Drawing No | 22-106-104 |         | Revision A     |

FUTURE STAGE V

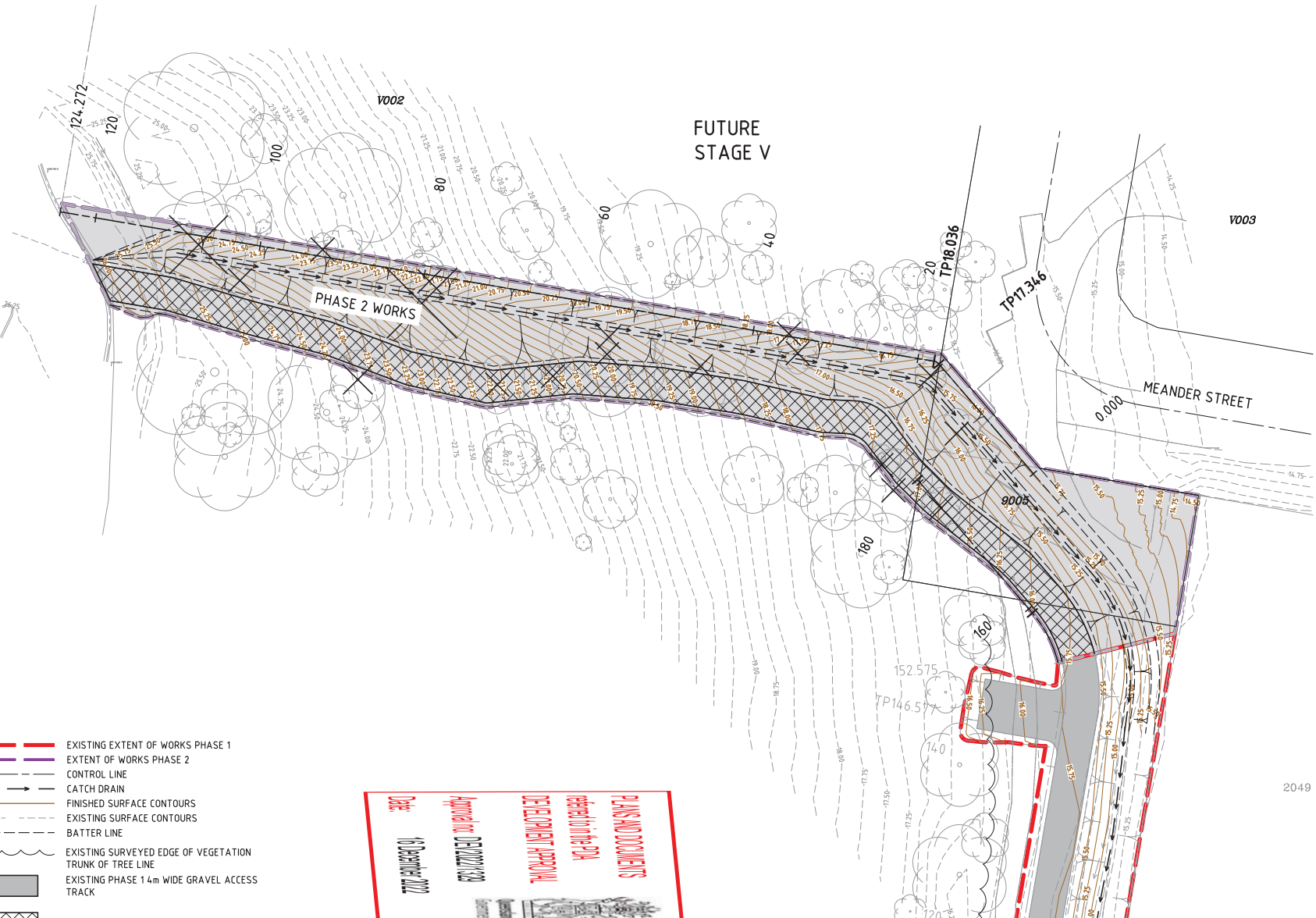

**EARTHWORKS CONTOUR PLAN**  
SCALE 1:250

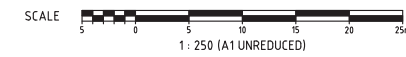

- LEGEND**
- EXISTING EXTENT OF WORKS PHASE 1
  - EXTENT OF WORKS PHASE 2
  - CONTROL LINE
  - CATCH DRAIN
  - FINISHED SURFACE CONTOURS
  - EXISTING SURFACE CONTOURS
  - BATTER LINE
  - EXISTING SURVEYED EDGE OF VEGETATION TRUNK OF TREE LINE
  - EXISTING PHASE 1 4m WIDE GRAVEL ACCESS TRACK
  - PROPOSED 4m WIDE GRAVEL ACCESS TRACK
  - EXISTING TREE
  - EXISTING TREE TO BE REMOVED TO BE CONFIRM BY OTHERS





DO NOT SCALE THIS DRAWING  
IF IN DOUBT - ASK!

LOCALITY PLAN

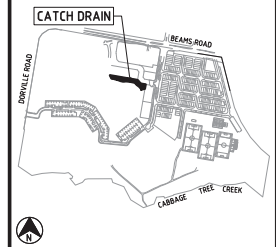

REVISIONS

| No | Description  | Date     | By |
|----|--------------|----------|----|
| A  | FOR APPROVAL | 25.07.22 | AA |

Client  
**ECONOMIC DEVELOPMENT QUEENSLAND (EDQ)**

Project  
**CARSELDINE VILLAGE CATCH DRAIN PHASE 2**

ABN 35 112 53 611  
11 62 Astor Tce  
Spring Hill Q 4000  
07 3017 1900  
www.kngroup.com.au

Approved  
*M. Shaw* Mark Andrew Shaw BEng (Civil), MIEAust, RPEQ 17544  
2022.07.27 13:35:54 +10'00'

Drawing title  
**CATCH DRAIN CROSS SECTIONS EXISTING PHASE 1 WORKS**

|                   |                |               |                   |
|-------------------|----------------|---------------|-------------------|
| Drawn<br>DES      | Designed<br>JB | Checked<br>MS | Date<br>JUL '22   |
| Scale<br>AS SHOWN |                |               | Sheet<br>05 of 10 |
| A1                | 22-106-105     | Revision      | A                 |

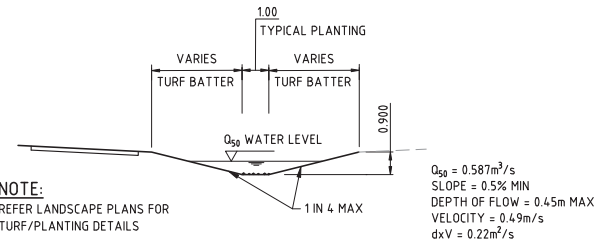

**CATCH DRAIN TYPICAL SECTION**  
NTS.

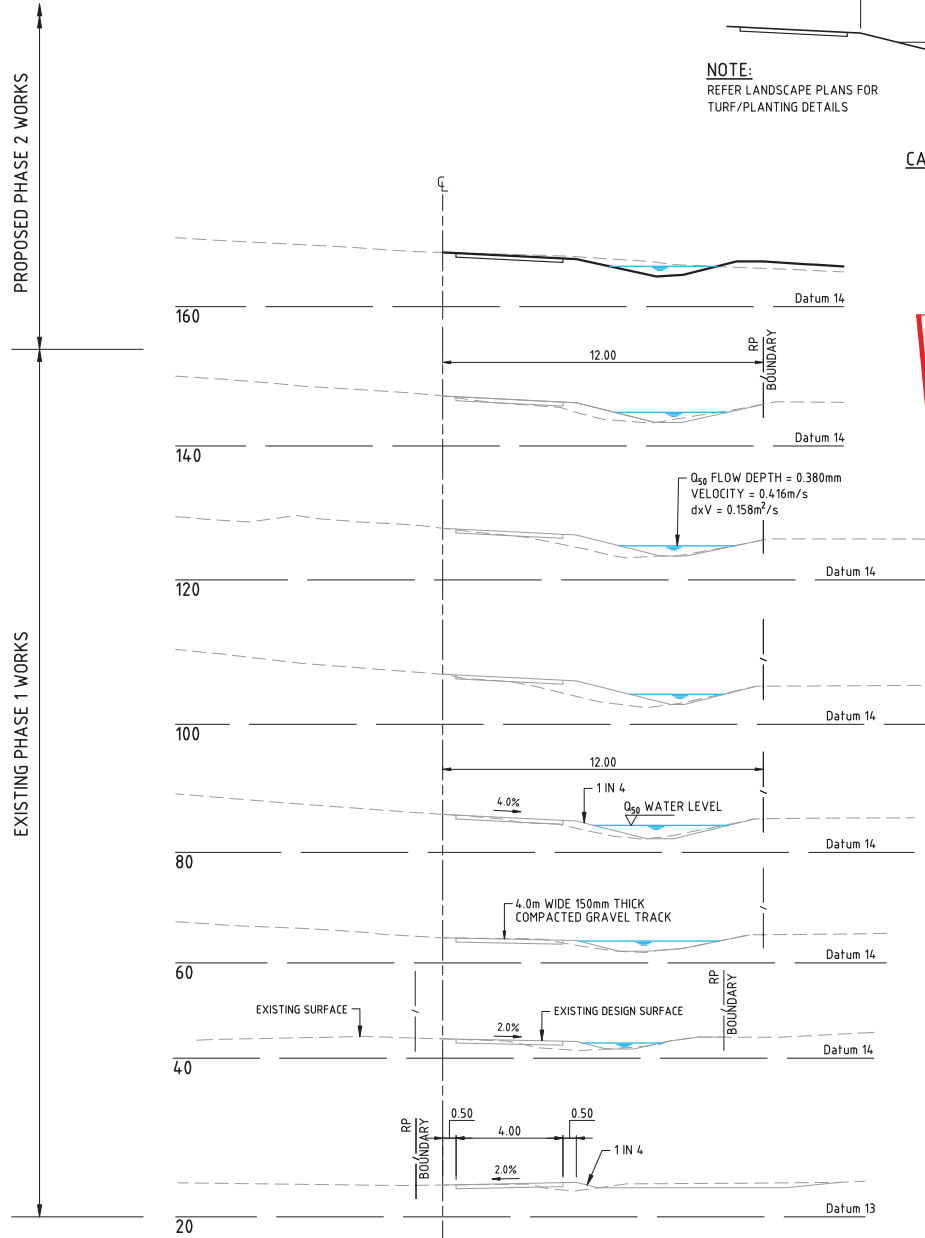

**CROSS SECTIONS - CATCH DRAIN PHASE 1 WORKS**

SCALE 1 : 100

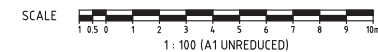

P:\3222\22766 Careldine Village Catch Drain\ACD\103 Series\22-106-105-106-X-Scavp Plot\In by AA on 27/07/2022 11:52:53 AM

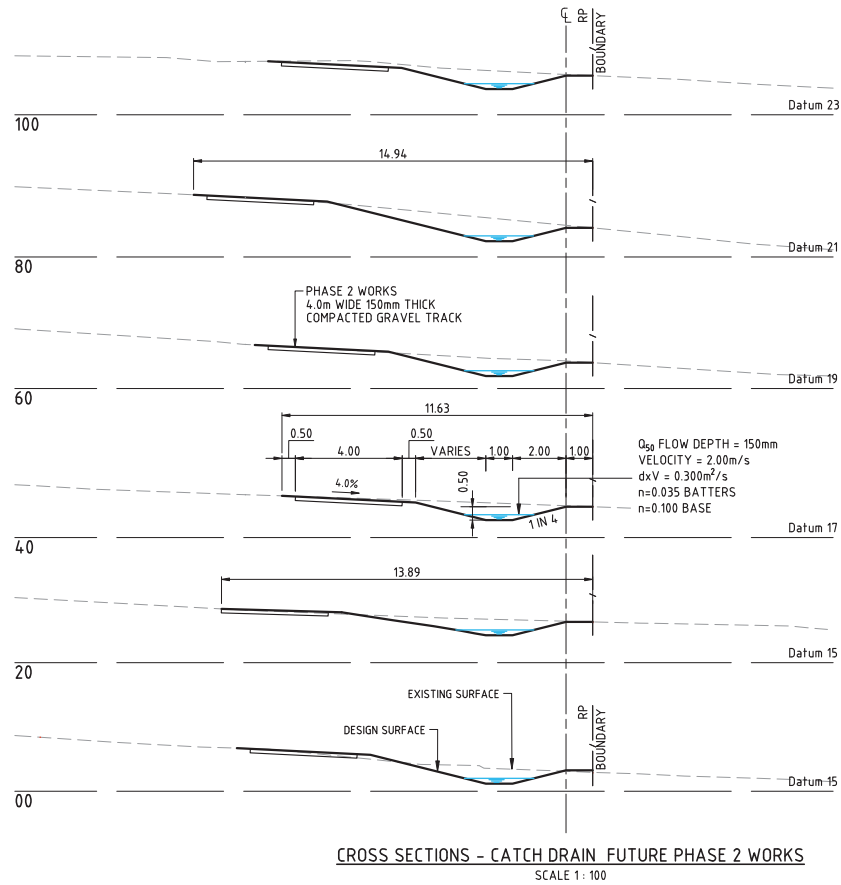

DO NOT SCALE THIS DRAWING  
IF IN DOUBT - ASK!

LOCALITY PLAN

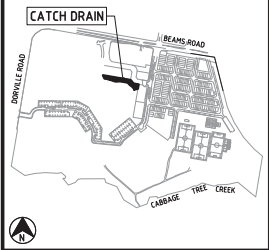

REVISIONS

| No | Description  | Date     | By |
|----|--------------|----------|----|
| A  | FOR APPROVAL | 25.07.22 | AA |
|    |              |          |    |
|    |              |          |    |
|    |              |          |    |
|    |              |          |    |
|    |              |          |    |
|    |              |          |    |
|    |              |          |    |
|    |              |          |    |
|    |              |          |    |
|    |              |          |    |
|    |              |          |    |
|    |              |          |    |

Client  
**ECONOMIC  
DEVELOPMENT  
QUEENSLAND (EDQ)**

Project  
**CARSELDINE VILLAGE  
CATCH DRAIN  
PHASE 2**



Approved  
*M. Shaw* Mark Andrew Shaw BEng  
(Civil), MIE Aust, RPEQ 17544  
2022.07.27 13:36:04 +10'00'

Drawing title  
**CATCH DRAIN  
CROSS SECTIONS  
PROPOSED PHASE 2 WORKS**

|                   |                          |               |                   |
|-------------------|--------------------------|---------------|-------------------|
| Drawn<br>DES      | Designed<br>JB           | Checked<br>MS | Date<br>JUL '22   |
| Scale<br>AS SHOWN | Drawing No<br>22-106-106 |               | Sheet<br>06 of 10 |
| A1                | Revision<br>A            |               |                   |

**LEGEND**  
 \_\_\_\_\_ SEDIMENT AND DIVERSION FENCE (TEMP)

DO NOT SCALE THIS DRAWING  
IF IN DOUBT - ASK!

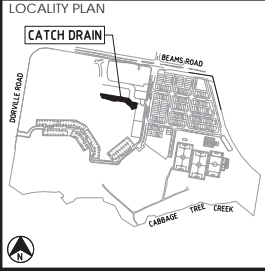

| REVISIONS |              |          |    |
|-----------|--------------|----------|----|
| No        | Description  | Date     | By |
| A         | FOR APPROVAL | 25.07.22 | AA |
|           |              |          |    |
|           |              |          |    |
|           |              |          |    |
|           |              |          |    |
|           |              |          |    |
|           |              |          |    |
|           |              |          |    |
|           |              |          |    |
|           |              |          |    |
|           |              |          |    |
|           |              |          |    |
|           |              |          |    |
|           |              |          |    |
|           |              |          |    |
|           |              |          |    |
|           |              |          |    |
|           |              |          |    |
|           |              |          |    |
|           |              |          |    |

Client  
**ECONOMIC DEVELOPMENT QUEENSLAND (EDQ)**

Project  
**CARSELDINE VILLAGE CATCH DRAIN PHASE 2**



Approved  
*M. Shaw* Mark Andrew Shaw BEng (Civil), MIEAust, RPEQ 17544  
 2022.07.27 13:36:16 +10'00'

Drawing title  
**EROSION AND SEDIMENT CONTOUR PLAN LAYOUT PLAN**

|                   |                          |               |                 |
|-------------------|--------------------------|---------------|-----------------|
| Drawn<br>DES      | Designed<br>JB           | Checked<br>MS | Date<br>JUL '22 |
| Scale<br>AS SHOWN | Sheet<br>07 of 10        |               | Revision        |
| A1                | Drawing No<br>22-106-107 | Revision<br>A |                 |

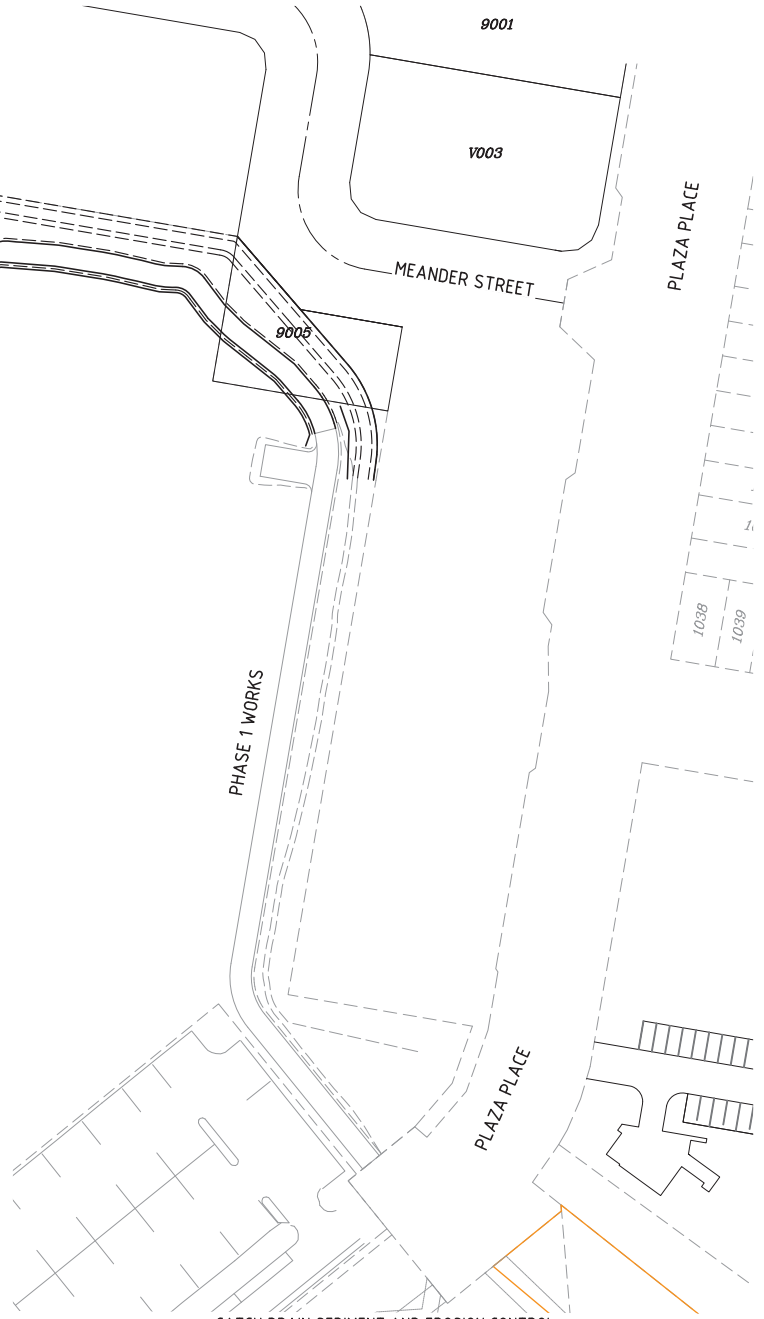

**CATCH DRAIN SEDIMENT AND EROSION CONTROL LAYOUT PLAN**  
 SCALE 1:500

SCALE 1:500 (A1 UNREduced)  
 10 5 0 10 20 30 40 50m

## EROSION AND SEDIMENT CONTROL PROGRAM

- THIS PROGRAM AND ASSOCIATED PLANS SHOULD BE READ IN CONJUNCTION WITH THE SITE MANAGEMENT SPECIFICATION INCORPORATED IN THE CONTRACT DOCUMENTS. THE PROVISIONS OF THE SPECIFICATION ARE TO BE STRICTLY ADHERED TO.
- THE BASIC OBJECTIVES OF THE EROSION AND SEDIMENT CONTROL ARE:
  - IDENTIFY CRITICAL AREAS AND PROVIDE APPROPRIATE ATTENTION TO THOSE AREAS.
  - PLAN SITE LAYOUTS SO THAT ACCESS TO ALL REQUIRED DRAINAGE EROSION AND SEDIMENT CONTROL MEASURE IS MAINTAINED.
  - LIMIT EXPOSURE TIME BY PROGRAMMING TO MINIMISE THE AREA OF LAND EXPOSED TO POTENTIALLY ADVERSE WEATHER CONDITIONS AT ANY ONE TIME. I.E. PROGRESSIVELY CLEAR AND REVEGETATE.
  - PROVIDE CONTROL MEASURES INCLUDING TEMPORARY AND PERMANENT DRAINAGE, EROSION AND SEDIMENT CONTROLS.
- THE EROSION AND SEDIMENT CONTROL SHALL COMPLY WITH BEST PRACTICE FOR EROSION AND SEDIMENT CONTROL, THE POLLUTION CONTROL MANUAL FOR URBAN STORMWATER MANAGEMENT, THE QUEENSLAND URBAN DRAINAGE MANUAL, AND THE SOIL EROSION AND SEDIMENT CONTROL - ENGINEERING GUIDELINES FOR QUEENSLAND (CURRENT EDITIONS).
- CONSTRUCTION SEQUENCE THE CONSTRUCTION SEQUENCE WILL GENERALLY BE:
  - OBTAIN ALL NECESSARY PERMITS AND APPROVALS BEFORE SITE ESTABLISHMENTS.
  - HOLD A PRE-CONSTRUCTION CONFERENCE.
  - STABILISE ALL CONSTRUCTION ACCESS ROUTES AND ENTRY/EXIT POINTS.
  - ESTABLISH SEDIMENT CONTROL STRUCTURES AND TEMPORARY DRAINAGE CONTROL MEASURES AS NECESSARY.
  - CARRY OUT BULK EARTHWORKS.
  - MAINTAIN AND REPAIR DRAINAGE, EROSION AND SEDIMENT CONTROL MEASURES.
  - REMOVE SEDIMENT CONTROL MEASURES WHEN THE SITE IS STABILISED. I.E. >70% GROUND COVER
  - THE CONTRACTOR SHALL PREPARE A SUPPLEMENTARY EROSION AND SEDIMENT CONTROL PLAN TO SUIT HIS/HER CONSTRUCTION METHODOLOGY, AND SUBMIT THIS PLAN FOR APPROVAL TO THE SUPERINTENDENT. IT SHOULD BE NOTED THAT ANY SIGNIFICANT VARIATION TO THIS PLAN MAY REQUIRE RESUBMISSION TO COUNCIL FOR APPROVAL. THE CLIENT SHALL NOT BE RESPONSIBLE FOR ANY SUCH ASSOCIATED DELAY.
- ALL ESC DEVICES ARE TO BE INSPECTED WEEKLY, PRIOR TO EXPECTED AND AFTER RAINFALL ANY DAMAGE IS TO BE REPAIRED AS REQUIRED TO MAINTAIN THEIR EFFICACY.
- ALL TEMPORARY EROSION AND SEDIMENT CONTROL (ESC) MEASURE TO BE MAINTAINED AND FULLY OPERATIONAL DURING THE MAINTENANCE PERIOD AND ARE TO BE REMOVED AFTER THE SATISFACTORY COMPLETION OF AN OFF-MAINTENANCE INSPECTION BY COUNCIL AND PRIOR TO FORMAL ACCEPTANCE "OFF MAINTENANCE" BY COUNCIL.
- PRIOR TO THE COMMENCEMENT OF CONSTRUCTION, THE CONTRACTOR IS TO PROVIDE A DETAILED PROGRAM TO THE SUPERINTENDENT SHOWING THE TIMING FOR ALL WORKS ASSOCIATED WITH THE PROJECT, NOMINATING, IN PARTICULAR, THE PROGRAM FOR INSTALLATION OF SOIL AND EROSION CONTROL SYSTEMS.
- EARTHWORKS SHALL BE CARRIED OUT IN SUCH A MANNER THAT THE SITE IS MAINTAINED IN A WELL DRAINED CONDITION, AREAS OF LOOSE SOIL ARE MINIMISED AND CONCENTRATIONS OF STORMWATER ARE MINIMISED. BULK EARTHWORKS WILL BE CARRIED OUT OVER THE ENTIRE SITE IN ONE STAGE.
- A SHAKE DOWN AS DETAILED ON THE PLAN COMPRISING FREE DRAINAGE GRAVEL SHALL BE LOCATED ADJACENT TO THE POINT OF ACCESS WHERE VEHICLES CAN BE WASHED DOWN PRIOR TO EXIT TO THE STREET SYSTEM IF REQUIRED. THE WASH DOWN AREA SHALL BE KEPT FREE OF MUD.
- FOR DETAILS OF ENTRY/EXIT SEDIMENT PAD REFER TO BEST PRACTICE EROSION & SEDIMENT CONTROL BOOK 1, PAGE 2.48, FIGURE 2.6.
- SUPPLEMENTARY EROSION AND SEDIMENT CONTROL DEVICES MAY BE REQUIRED AT THE DISCRETION OF THE SUPERINTENDENT.
- SEDIMENTATION FENCES TO BE PLACED AS SHOWN. FOR DETAILS OF SEDIMENT FENCE REFER BEST PRACTICE EROSION & SEDIMENT CONTROL BOOK 1, PAGE 2.50, FIGURE 2.8.
- WHERE SEDIMENT FENCES ARE SHOWN TO BE CONSTRUCTED IN AREAS OF SIGNIFICANT EARTHWORKS, ERECTION OF THE FENCE MAY BE DEFERRED UNTIL COMPLETION OF THE BULK EARTHWORKS, SUBJECT TO ABSENCE OF RAIN.

## TREES

- ENSURE COMPLIANCE WITH THE REQUIREMENTS OF AS4970 - TREES ON CONSTRUCTION SITES. THIS MAY REQUIRE CONSULTATION AND GUIDANCE FROM A CLASS V CERTIFIED ARBORIST AS TREES OUTSIDE THE IMMEDIATE WORK AREA MAY BE AFFECTED.
- ENSURE COMPLIANCE WITH THE REQUIREMENTS OF THE 28 SOUTH ENVIRONMENTAL FMP, INCLUDING IMPLEMENTING THE NOMINATED TREE PROTECTION ZONES.

## EROSION AND SEDIMENT CONTROL NOTES

- NO DISTURBED AREA IS TO REMAIN DENUDED LONGER THAN 60 DAYS.
- ALL EROSION AND SILTATION CONTROL MEASURES ARE TO BE PLACED PRIOR TO OR AS THE FIRST STEP IN CLEARING AND GRUBBING OR ANY OTHER EARTHWORKS OR TRENCHING.
- ALL STORMWATER, SEWER LINE AND SERVICES TRENCHES NOT IN STREETS ARE TO BE MULCHED AND SEEDED WITHIN 15 DAYS AFTER BACKFILL, NO MORE THAN 150 METRES ARE TO BE OPEN AT ANY ONE TIME.
- ALL TEMPORARY EARTH BANKS, DIVERSIONS AND SEDIMENT DAM EMBANKMENTS ARE TO BE MACHINE-COMPACTED, SEEDED AND MULCHED FOR TEMPORARY VEGETATIVE COVER WITHIN 10 DAYS AFTER GRADING. STRAW OR HAY MULCH IS REQUIRED.
- ALL FILL EMBANKMENTS ARE TO BE LEFT WITH A LIP AT THE TOP OF THE SLOPE AT THE END OF EACH DAYS OPERATION.
- ALL CUT AND FILL BATTERS ARE TO BE SEEDED AND MULCHED WITHIN 10 DAYS OF COMPLETION OF GRADING.
- ADDITIONAL SILT AND EROSION CONTROLS MAY BE REQUIRED AS ORDERED ON SITE BY THE SUPERVISING ENGINEER.
- ALL CONTROLS ARE TO BE INSPECTED AFTER EACH STORM EVENT AND MAINTAINED AS REQUIRED. CONTROLS ARE TO BE MAINTAINED UNTIL THE DISTURBED AREAS ARE PERMANENTLY STABILIZED OR UNTIL NO LONGER REQUIRED.

### PHASE 1 - CLEARING AND BULK EARTHWORKS

CONSTRUCT AND MAINTAIN SILT FENCES, STRAW BALE TRAPS, ALLOTMENT DRAINAGE BANKS, CATCH DRAINS AND HYDROMULCHING WHICH CONTROL SEDIMENT AND EROSION DURING CLEARING AND BULK EARTHWORKS.

### PHASE 2 - TRENCH EXCAVATION

CONSTRUCT AND MAINTAIN SILT FENCES, STRAW BALE TRAPS, ALLOTMENT DRAINAGE BANKS AND CATCH DRAINS WHICH CONTROL SEDIMENTATION AND EROSION DURING TRENCHING WORK.

### PHASE 3 - PAVEMENT CONSTRUCTION

CONSTRUCT AND MAINTAIN SILT FENCES, STRAW BALE TRAPS, ALLOTMENT DRAINAGE BANKS, GULLY INLET PROTECTION, AND PIPE INLET/OUTLET PROTECTION WHICH CONTROL SEDIMENTATION AND EROSION DURING PAVEMENT CONSTRUCTION. SAND BAGGING TO BE PLACED ACROSS PAVEMENT TO CONTROL RUNOFF IN PAVEMENT BOXING AS DIRECTED ON SITE.

### PHASE 4 - MAINTENANCE PERIOD

CONSTRUCT AND MAINTAIN CONTROLS AND VEGETATIVE TREATMENTS WHICH CONTROL SEDIMENTATION AND EROSION PRIOR TO THE ESTABLISHMENT OF GRASS COVER. PROVIDE 600mm WIDE GRASS FILTER STRIPS BEHIND KERB AND CHANNEL.

NOTE: TURF TREATMENT IN CERTAIN AREAS BY LANDSCAPER. REFER TO LANDSCAPE DRAWING.

### NOTE

ALL VEHICLES EXITING FROM THE SITE ARE TO BE CLEANED AND TREATED TO PREVENT MATERIAL BEING TRACKED OR DEPOSITED ONTO PUBLIC ROADS. IF MATERIAL IS ACCIDENTLY DEPOSITED ONTO PUBLIC ROADS IT SHALL BE REMOVED WITHOUT DELAY. IF THE SHAKEDOWN DEVICE PROVES TO BE INEFFECTIVE THE CONTRACTOR IS TO USE OTHERS MEANS TO PREVENT MATERIAL BEING DEPOSITED ONTO PUBLIC ROADS.

## TOPSOIL

- STRIP AND STOCKPILE AVAILABLE TOPSOIL (ASSUMED AVERAGE DEPTH 150mm) FROM ALL DISTURBED AREAS PRIOR TO BULK EARTHWORKS. GRADE EVENLY BETWEEN ALLOTMENT FINISHED SURFACE LEVELS AND ENSURE LOTS ARE FREE DRAINING.
- MINIMUM SLOPE ACROSS ALLOTMENTS TO BE 1%.
- ALL FOOTPATHS, BATTERS, AND EARTHWORKS AFFECTED ALLOTMENTS ARE TO BE TOPSOILED TO A MINIMUM DEPTH OF 150mm (LIGHTLY COMPACTED) AND TURFED WHERE SPECIFIED.

## SEDIMENT FENCES

- SEDIMENT FENCES TO BE PLACED AS SHOWN. SEDIMENT FENCED TO BE REPAIRED AND EXCESSIVE SEDIMENT DEPOSITS SHALL BE REMOVED ONCE CAPACITY FALLS BELOW 75%.
- FOR DETAILS OF SEDIMENT FENCE REFER BEST PRACTICE EROSION & SEDIMENT CONTROL BOOK 1, PAGE 2.50, FIGURE 2.8.
- SEDIMENT FENCES TO BE REPAIRED AS REQUIRED AND EXCESSIVE SEDIMENT DEPOSITS SHOULD BE REMOVED.
- INSTALL KERB INLETS WITH GRAVEL RANGING FROM 50mm TO 75mm IN SIZE SHALL BE INSTALLED AT ALL COMPLETED INLETS. REFER IPWEAQ STANDARD DRAWING D-004.1. THESE SHALL BE MAINTAINED IN A CLEAN CONDITION. IN THE EVENT OF HEAVY RAIN THEY SHALL BE REMOVED TO MINIMISE THE POTENTIAL FOR FLOODING.
- CHECKS OF SILT CONTROL DEVICES ARE TO BE MADE WEEKLY, OR AFTER ANY SIGNIFICANT STORM EVENT TO ENSURE INTEGRITY AND PERFORMANCE.

## TURFING

- PROVIDE TURFING TO ENTIRE WIDTH OF ALL SWALES, FOOTPATHS AND 1 IN 4 CUT AND FILL BATTERS.
- FOOTPATH BATTERS ARE TO BE STABILISED WITH TOPSOIL (AND TURFED) AS SOON AS PRACTICAL AFTER THE BATTERS HAVE BEEN COMPLETED.

## DURING CONSTRUCTION SEQUENCE:

- TOPSOIL STOCKPILES SHALL BE LESS THAN 1m DEEP AND UNCOMPACTED. A SEDIMENTATION FENCE SHALL BE CONSTRUCTED ON THE D/S SIDE, OR THE STOCKPILE STABILISED WITH VEGETATION, MULCH, OR A SOIL STABILISER.
- SEDIMENTATION FENCES TO BE PLACED AS SHOWN.
- REGULARLY INSPECT BANKS AND REPAIR ANY SLUMPS, WHEEL TRACK DAMAGE OR LOSS OF FREEBOARD.
- REMOVE SEDIMENT TO AVOID PONDING FROM CATCH DRAINS.
- REMOVE EXCESSIVE SEDIMENT FROM UPSTREAM OF CHECK DAM.
- ROAD RESERVE TO BE USED AS HAUL ROAD.
- A CATCH DRAIN OR DIVERSION BANK IS TO BE PROVIDED ON THE TOP SIDE OF ALL CUTS, WITH DISCHARGE EITHER TO UNDISTURBED GRASS LANDS OR TO THE CROSS ROAD DRAINAGE.
- SUPPLEMENTARY EROSION AND SEDIMENT CONTROL DEVISED MAY BE REQUIRED AT THE DISCRETION OF THE ENGINEER.
- WATER QUALITY SAMPLES MUST BE TAKEN AND ANALYSED PRIOR TO THE RELEASE OF ANY WATER FROM THE SEDIMENT POND. WATER QUALITY MUST SATISFY THE FOLLOWING CRITERIA: TSS-50MG/L PH BETWEEN 6.5 AND 8.5.
- ALL WATER QUALITY DATA INCLUDING DATES OF RAINFALL, TESTING AND WATER RELEASE MUST BE MAINTAINED IN AN ON-SITE REGISTER. THIS REGISTER IS TO BE MAINTAINED FOR THE DURATION OF THE APPROVED WORKS AND BE AVAILABLE ON SITE FOR INSPECTION BY COUNCIL OFFICERS ON REQUEST.
- EXPOSED AREAS ON LOTS ARE TO BE SEEDED AND MULCHED (E.G. HYDROMULCHED). MULCH SHALL BE APPLIED AT A MINIMUM RATE OF 2.5T/HA. ALTERNATIVELY THEY SHALL BE DRILL-SEEDED AND IRRIGATED SO AS TO ENSURE >70% GROUND COVER WITHIN 14 DAYS FROM NOVEMBER TO APRIL, OR 30 DAYS FROM MAY TO OCTOBER.

## FOLLOWING CONSTRUCTION:

- SEDIMENTATION FENCES TO BE MAINTAINED UNTIL TURFING IS COMPLETED.
- SEDIMENT BASINS TO BE CHECKED AFTER EVERY SIGNIFICANT STORM AND DESILTED ONCE THE SETTLEMENT LIMIT HAS BEEN REACHED.

## STABILISATION:

- THE AMOUNT OF AREA EXPOSED AT ANY ONE TIME TO BE MINIMISED BY STAGING THE WORKS WHEREVER POSSIBLE AND AIMING TO ACHIEVE FINISHED LEVEL IN EACH AREA AS QUICKLY AS POSSIBLE BEFORE OPENING NEW AREAS.
- TOPSOIL TO BE STRIPPED AND STOCKPILED SEPARATELY TO SUB-SOILS.
- STOCKPILES TO BE PROVIDED WITH SURFACE COVER USING A CHEMICAL SURFACE STABILISER SUCH AS VITAL CHEMICALS VITAL-BON MATT STONEMATE.
- IF WORKS ARE DELAYED OR PUT ON HOLD THEN TEMPORARY EROSION CONTROL COVERING TO BE PROVIDED USING VITAL CHEMICALS VITAL-BON MATT P47-VR1 OR EQUIVALENT.
- ONCE AREAS REACH FINISHED LEVEL:
  - TOPSOIL TO BE SPREAD TO CAP/BURY THE DISPERSIVE SUBSOILS.
  - TOPSOIL TO BE DRILL-SEEDED WITH A MIXTURE OF ANNUAL AND PERENIAL GRASS SPECIES (REFER TABLE) AND FERTILISER WITH CROP-KING 88 (0.3T/HA).
  - TEMPORARY SOIL COVER TO BE APPLIED CONSISTING OF VITAL CHEMICALS VITAL-BON MATT P47-VR1 OR EQUIVALENT.
  - WATERING UNDERTAKEN AS NECESSARY UNTIL STABLE GRASS SURFACE COVER IS ESTABLISHED.

|   | SEED MIXES  |   |   |
|---|---|---|---|
|   | SUMMER BLEND<br>(APPLICATIONS NOVEMBER -<br>DECEMBER) | MID SEASON BLEND<br>(APPLICATIONS MARCH/APRIL &<br>SEPTEMBER/OCTOBER) | WINTER BLEND<br>(APPLICATIONS MAY AUGUST) |
| UNMULLED GREEN COUCH (CYNODON<br>DACTYLONI OR BLUE COACH (DIGITARIA<br>DIDACYLIA) | 25%   | 25%   | 25%                                       |
| MULLED GREEN COUCH (CYNODON<br>DACTYLONI OR BLUE COACH (DIGITARIA<br>DIDACYLIA)   | 25%   | 25%   | 25%                                       |
| JAPANESE MILLET   | 30%   | 15%   | N/A                                       |
| RYE GRASS   | N/A   | 15%   | 30%                                       |
| CARPET GRASS (AXONOPUS AFFINIS)   | 20%   | 20%   | 20%                                       |

DO NOT SCALE THIS DRAWING  
IF IN DOUBT - ASK!

## LOCALITY PLAN

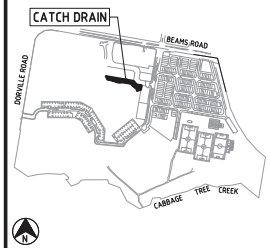

## REVISIONS

| No | Description  | Date     | By |
|----|--------------|----------|----|
| A  | FOR APPROVAL | 25.07.22 | AA |
|    |              |          |    |
|    |              |          |    |
|    |              |          |    |
|    |              |          |    |

Client

ECONOMIC  
DEVELOPMENT  
QUEENSLAND (EDQ)

Project

CARSELDINE VILLAGE  
CATCH DRAIN  
PHASE 2



Approved

M. Shaw Mark Andrew Shaw BEng  
(Civil), MIEAust, RPEQ 17544  
2022.07.27 13:36:26 +10'00'

Drawing Title

EROSION AND SEDIMENT  
CONTOUR PLAN  
NOTES

| Drawn      | Designed   | Checked | Date    |
|------------|------------|---------|---------|
| DES        | JB         | MS      | JUL '22 |
| Scale      | Sheet      |         |         |
| AS SHOWN   | 08 of 10   |         |         |
| Drawing No | Revision   |         |         |
| A1         | 22-106-108 | A       |         |



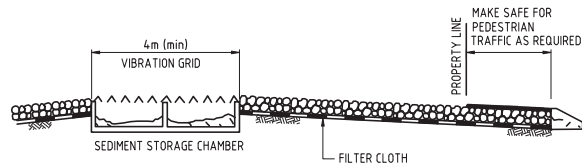

TYPICAL PROFILE OF A VIBRATION GRID  
SITE ACCESS POINT SHAKEDOWN FACILITY  
N.T.S.

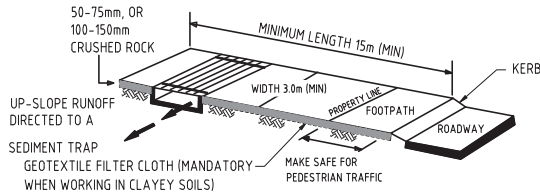

SITE ACCESS POINT ENTRY/EXIT PAD  
N.T.S.

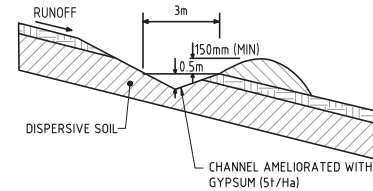

CATCH DRAIN

| OPEN EARTH SLOPES |        |       |       |        |       | VEGETATED SLOPES |               |       |  |
|-------------------|--------|-------|-------|--------|-------|------------------|---------------|-------|--|
| SLOPE             | HORIZ. | VERT. | SLOPE | HORIZ. | VERT. | SLOPE            | HORIZ.        | VERT. |  |
| 1%                | 80m    | 0.9m  | 15%   | 19m    | 2.9m  | -10%             | NO MAXIMUM    |       |  |
| 2%                | 60m    | 1.2m  | 20%   | 16m    | 3.2m  | 12%              | 100m          | 12m   |  |
| 4%                | 40m    | 1.6m  | 25%   | 14m    | 3.5m  | 15%              | 80m           | 12m   |  |
| 6%                | 32m    | 1.9m  | 30%   | 12m    | 3.5m  | 20%              | 55m           | 11m   |  |
| 8%                | 28m    | 2.2m  | 35%   | 10m    | 3.5m  | 25%              | 40m           | 10m   |  |
| 10%               | 25m    | 2.5m  | 40%   | 9m     | 3.5m  | 30%              | 30m           | 9m    |  |
| 12%               | 22m    | 2.6m  | 50%   | 6m     | 3.0m  | +36%             | CASE SPECIFIC |       |  |

TYPICAL CATCH DRAINS DIMENSIONS & SPACINGS

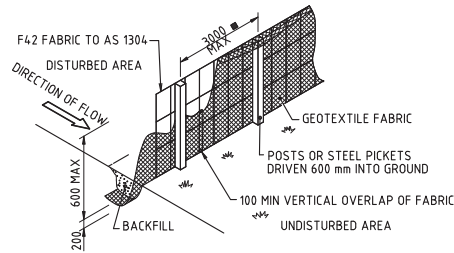

SEDIMENT FENCE  
N.T.S.

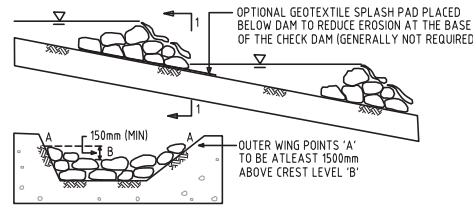

SECTION 1 - 1  
CHECK DAM  
N.T.S.

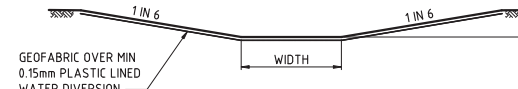

TYPICAL LINED CATCH DRAIN

SCALE 1: 40

SIZING TO BE DETERMINED DURING CONSTRUCTION

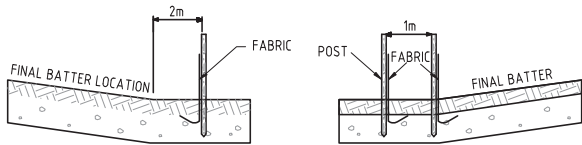

a) PLACEMENT OF SEDIMENT FENCE AT BASE OF FILL SLOPE

b) USE OF DOUBLE SEDIMENT FENCE AT THE BASE OF FILL SLOPE

SEDIMENT FENCE DETAILS  
N.T.S.

LOCATION OF SEDIMENT FENCE AT BASE OF FILL SLOPE

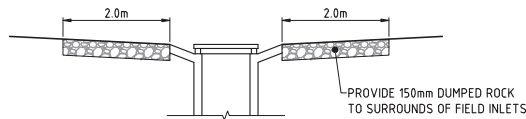

FIELD INLET PROTECTION  
N.T.S.

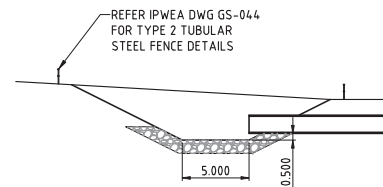

TEMPORARY HEADWALL DETAIL  
SCALE N.T.S.

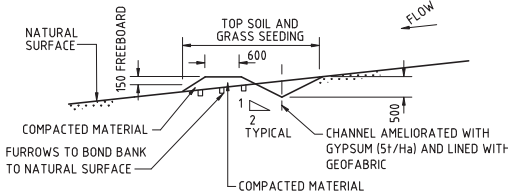

CROSS SECTION  
DIVERSION CHANNEL  
N.T.S.

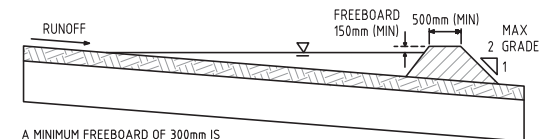

A MINIMUM FREEBOARD OF 300mm IS RECOMMENDED FOR NON-VEGETATED EARTH EMBANKMENTS

DIVERSION DRAINAGE BANK  
N.T.S.

DO NOT SCALE THIS DRAWING IF IN DOUBT - ASK!

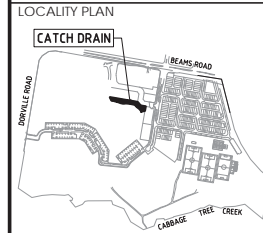

REVISIONS

| No | Description  | Date     | By |
|----|--------------|----------|----|
| A  | FOR APPROVAL | 25.07.22 | AA |

Client  
ECONOMIC DEVELOPMENT QUEENSLAND (EDQ)

Project  
CARSELDINE VILLAGE CATCH DRAIN PHASE 2



Approved  
M. Shaw  
Mark Andrew Shaw BEng (Civil), MIEAust, RPEQ 17544  
2022.07.27 13:36:36 +10'00'

Drawing title  
EROSION AND SEDIMENT CONTOUR PLAN DETAILS

| Drawn      | Designed   | Checked | Date    |
|------------|------------|---------|---------|
| DES        | JB         | MS      | JUL '22 |
| Scale      | Sheet      |         |         |
| AS SHOWN   | 09 of 10   |         |         |
| Drawing No | Revision   |         |         |
| A1         | 22-106-109 |         | A       |

PI 33221-2206 Carseldine Village Catch Drain (ACAD) Series 02-06-07-09-SEDIMENT Log Plotted by: AA on 27/07/2022 15:55:54

DO NOT SCALE THIS DRAWING  
IF IN DOUBT - ASK!

LOCALITY PLAN

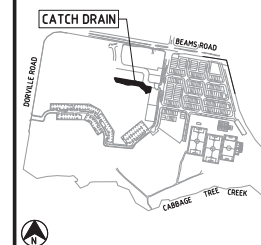

REVISIONS

| No | Description  | Date     | By |
|----|--------------|----------|----|
| A  | FOR APPROVAL | 25.07.22 | AA |
|    |              |          |    |
|    |              |          |    |
|    |              |          |    |
|    |              |          |    |
|    |              |          |    |
|    |              |          |    |
|    |              |          |    |
|    |              |          |    |
|    |              |          |    |

Client: ECONOMIC DEVELOPMENT QUEENSLAND (EDQ)  
 Project: CARSELDINE VILLAGE – CATCH DRAIN (PHASE 2)  
 Prepared By: Jason Burton Date: 27<sup>th</sup> July 2022  
 Reviewed By: Mark Shaw Date: 27<sup>th</sup> July 2022

**Safety in Design Analysis**

• Complete Safety in Design Analysis by populating the table where applicable with all of the relevant safety issues for the project. For example:

|  |   |
|--|---|
| <input type="checkbox"/> Positioning of new services adjacent to existing live services<br><input checked="" type="checkbox"/> Construction adjacent to existing road carriageways<br><input type="checkbox"/> Pedestrians<br><input checked="" type="checkbox"/> Civil Construction Workers<br><input checked="" type="checkbox"/> Maintenance Workers<br><input checked="" type="checkbox"/> Work Place Health and Safety Constraints<br><input type="checkbox"/> Unusual material handling<br><input type="checkbox"/> Falls from heights<br><input checked="" type="checkbox"/> Underground Services (existing)<br><input type="checkbox"/> Electrical Service Installation<br><input type="checkbox"/> Gas Service Installation<br><input type="checkbox"/> Communication Installation<br><input type="checkbox"/> Traffic Signal Installation<br><input checked="" type="checkbox"/> Landscape Workers<br><input type="checkbox"/> Line marking Workers<br><input checked="" type="checkbox"/> Excavation – open cut trenching - Trench excavation depths<br><input type="checkbox"/> Tunnel Boring<br><input checked="" type="checkbox"/> Confined Spaces<br><input checked="" type="checkbox"/> Lifting of loads<br><input checked="" type="checkbox"/> Unloading of materials and storage<br><input type="checkbox"/> Storage of hazardous materials<br><input checked="" type="checkbox"/> Geotechnical investigation – works<br><input checked="" type="checkbox"/> Bulk Earthworks<br><br><input checked="" type="checkbox"/> List all relevant safety studies | <input checked="" type="checkbox"/> Slope stability<br><input type="checkbox"/> Retaining Walls<br><input checked="" type="checkbox"/> Dust Control<br><input checked="" type="checkbox"/> Erosion and Sediment Control/Management<br><input checked="" type="checkbox"/> Sediment Basin Construction<br><input type="checkbox"/> Wetland/Dam Construction<br><input type="checkbox"/> Working under traffic<br><br>Project Specific Design Elements: |
|--|---|

The following table summarises the safety in design issues considered.

| Section of Works                            | Identify any Potential Incident or Hazard  | Consequence | Likelihood | Risk Rating | Risk Control Measures  | Consequence | Likelihood | Residual Risk Rating (after design applied) | Risk Manager         |
|---|--|-------------|------------|-------------|--|-------------|------------|---|----------------------|
| Earthworks Material Investigation           | Geotechnical Investigation   | C           | 3          | S           | SWMS required by Contractor  | D           | 3          | M   | Contractor           |
| Road/Earthworks Works                       | Pedestrians Injury   | D           | 3          | M           | TMP to be provided by Contractor to exclude pedestrians from work site   | E           | 3          | L   | Contractor           |
|   | Civil Construction Workers – Injury  | A           | 4          | H           | TMP and SWMS required for all activities   | C           | 2          | S   | Contractor           |
|   | Maintenance Workers  | A           | 4          | H           | TMP and SWMS required for all activities   | C           | 3          | S   | Contractor           |
|   | Underground Services (Existing)  | A           | 3          | H           | DBYD information to be sorted prior to design. Existing to be located by survey if applicable to design. All existing services to be located and depths confirmed prior to commencement. SWMS to be provided by Contractor | C           | 2          | S   | Designer/ Contractor |
| Working adjacent to existing Infrastructure | Conflict between construction equipment / personnel and live infrastructure in particular Power lines          | B           | 4          | S           | All existing services highlighted in the documentation. Contractor to complete DBYD search before commencing works. SWMS to be provided by Contractor  | C           | 4          | M   | Designer/ Contractor |
| Service trench/ pipe installation           | Location of all trenches to provide clearance to all other services and all structures or battered embankments | A           | 4          | H           | Mains located with safe working clearance to existing pressure mains, structures and battered embankments  | C           | 4          | M   | Designer             |
|   | Trench depth   | A           | 4          | M           | Depth of trenches minimized for both safety and cost efficiency  | C           | 4          | M   | Designer             |
| Works within Confined Spaces                | Construction of stormwater, sewer, water and wetland structures  | A           | 4          | M           | Contractor to ensure works undertaken in a manner complying with safe work method statements   | D           | 5          | L   | Contractor           |
| Silt and Erosion Control                    | Public access to water retaining temporary sediment basins   | A           | 5          | S           | Protection measures – that i fencing of all water retaining structures with side slopes greater than 1 in 5 as described in International Erosion Control Association (Australasian) Table B9                              | C           | 4          | M   | Designer/ Contractor |

**RISK ASSESSMENT AND CONTROL**

| Risk Assessment  |   |            |               |
|--|---|------------|---------------|
| Select <b>one</b> category from each of the columns below that best represents the likely outcome if the potential hazard actually did occur. For each consequence consider the <b>most likely outcome</b> and <b>not</b> the 'absolute worst' case. |   |            |               |
| Consequence  |   | Likelihood |               |
| <b>A</b>   | Death – major environmental damage                    | 1          | Certain       |
| <b>B</b>   | Permanent Disability – severe environmental damage    | 2          | Probable      |
| <b>C</b>   | Lost Time Injury – moderate environmental damage      | 3          | Possible      |
| <b>D</b>   | Medical Treatment Injury – minor environmental damage | 4          | Unlikely      |
| <b>E</b>   | First Aid Treatment                                   | 5          | Very Unlikely |

**RISK RATING**

**Certain** - means an event or situation that is happening more or less all the time, including continuous situations  
**Permanent Disability** – means a disability, such as loss of a limb or eyesight, loss of hearing, chronic skin disorder, chronic back disorder, emphysema, and the like



|   |                         |          |                            |          |          |
|---|-------------------------|----------|----------------------------|----------|----------|
|   | <b>H: High Risk</b>     |          | <b>S: Significant Risk</b> |          |          |
|   | <b>M: Moderate Risk</b> |          | <b>L: Low Risk</b>         |          |          |
| Read the Risk Rating from the matrix below: |                         |          |                            |          |          |
| <b>Risk Assessment Matrix</b>               | <b>A</b>                | <b>B</b> | <b>C</b>                   | <b>D</b> | <b>E</b> |
| <b>1</b>                                    | H                       | H        | H                          | S        | S        |
| <b>2</b>                                    | H                       | H        | S                          | S        | M        |
| <b>3</b>                                    | H                       | H        | S                          | M        | L        |
| <b>4</b>                                    | H                       | S        | M                          | L        | L        |
| <b>5</b>                                    | S                       | S        | M                          | L        | L        |

**Probable** – means an event or situation that occurs or is likely to occur about ten times or more per year  
**Possible** – means an event or situation that occurs or is likely to occur about once per year  
**Unlikely** – means an event or situation that occurs or is likely to occur less frequently than once every ten years

Client  
**ECONOMIC DEVELOPMENT QUEENSLAND (EDQ)**

Project  
**CARSELDINE VILLAGE CATCH DRAIN PHASE 2**



Approved  
 M. Shaw Mark Andrew Shaw BEng (Civil), MIE Aust, RPEQ 17544  
 2022.07.27 13:36:46 +10'00'

Drawing title  
**SAFETY IN DESIGN**

|                |                       |            |                |
|----------------|-----------------------|------------|----------------|
| Drawn DES      | Designed JB           | Checked MS | Date JUL '22   |
| Scale AS SHOWN | Drawing No 22-106-110 |            | Sheet 10 of 10 |
| A1             | Revision A            |            |                |

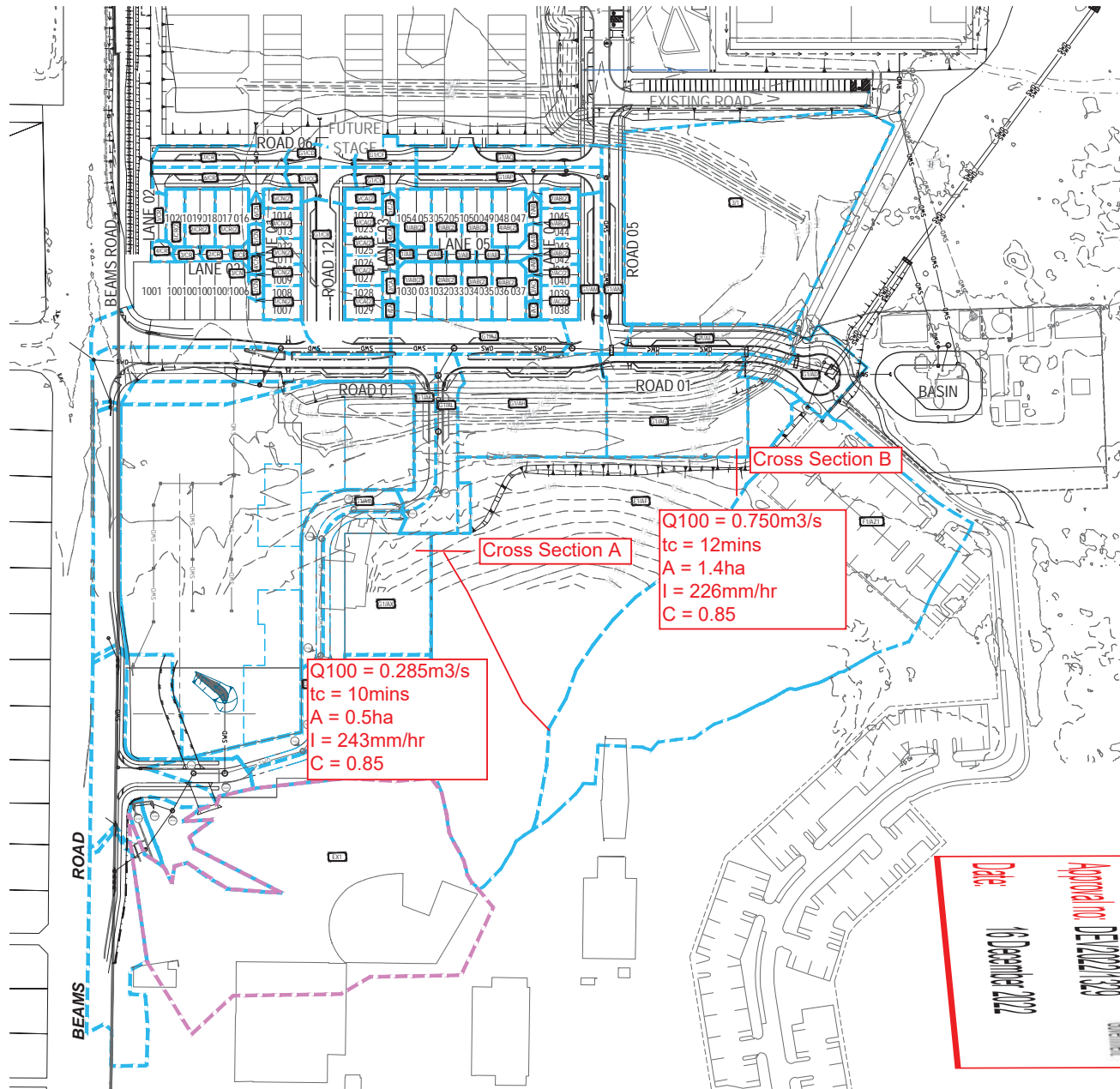

NOTE:  
 REFER DRG.15-003002.01-1410 FOR LEGEND AND NOTES.

**PLANS AND DOCUMENTS**  
 referred to in the PDA  
**DEVELOPMENT APPROVAL**

Approved on: 16 December 2022  
 Date: 16 December 2022



PDA\_REF\_NO.DEV2019/1074

| REVISION | DATE     | ISSUE DETAILS  |
|----------|----------|----------------|
| A        | 23.03.21 | LINE AZ1 ADDED |

| DRAWN | DESIGN |
|-------|--------|
| AR    | AA     |

| DRAWN CHECK | STATUS           |
|-------------|------------------|
| AA          | FOR CONSTRUCTION |

APPROVED: LESLIE ROCHE  
 FOR & ON BEHAL OF SERVICES PTY LTD

| SCALE            |
|------------------|
| 1:1000<br>1:2000 |



CLIENT  
**ECONOMIC DEVELOPMENT QUEENSLAND**



PROJECT  
**CARSELDINE URBAN VILLAGE STAGE 1**

DISCLAIMER  
 ALL DIMENSIONS TO BE CHECKED ON SITE BY CONTRACTOR PRIOR TO CONSTRUCTION, USE WRITTEN DIMENSIONS ONLY. DO NOT SCALE.

| DRAWING TITLE                               | PROJECT NO.  | DRAWING NO. | REVISION |
|---|--------------|-------------|----------|
| STORMWATER DRAINAGE EXTERNAL CATCHMENT PLAN | 15-003002.01 | 1412        | A        |

# CARSELDINE VILLAGE BEAMS ROAD, CARSELDINE - CATCH DRAIN - PHASE 1 LANDSCAPE DOCUMENTATION

ISSUE C 01.07.2022  
REVISED COUNCIL SUBMISSION  
DRAWING SCHEDULE

| DWG NO.    | DRAWING TITLE                      | ISSUE | DATE       |
|------------|------------------------------------|-------|------------|
| 10448 L 40 | LANDSCAPE COVER SHEET              | C     | 01.07.2022 |
| 10448 L 41 | LANDSCAPE LAYOUT AND PLANTING PLAN | C     | 01.07.2022 |
| 10448 L 42 | LANDSCAPE CONSTRUCTION DETAILS     | C     | 01.07.2022 |

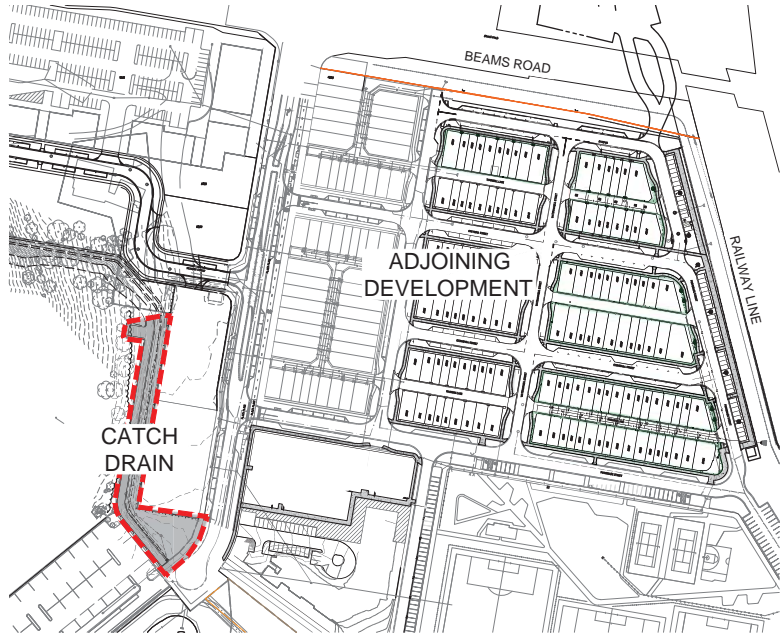

**SITE LAYOUT PLAN**  
SCALE: 1:1500 @ A1

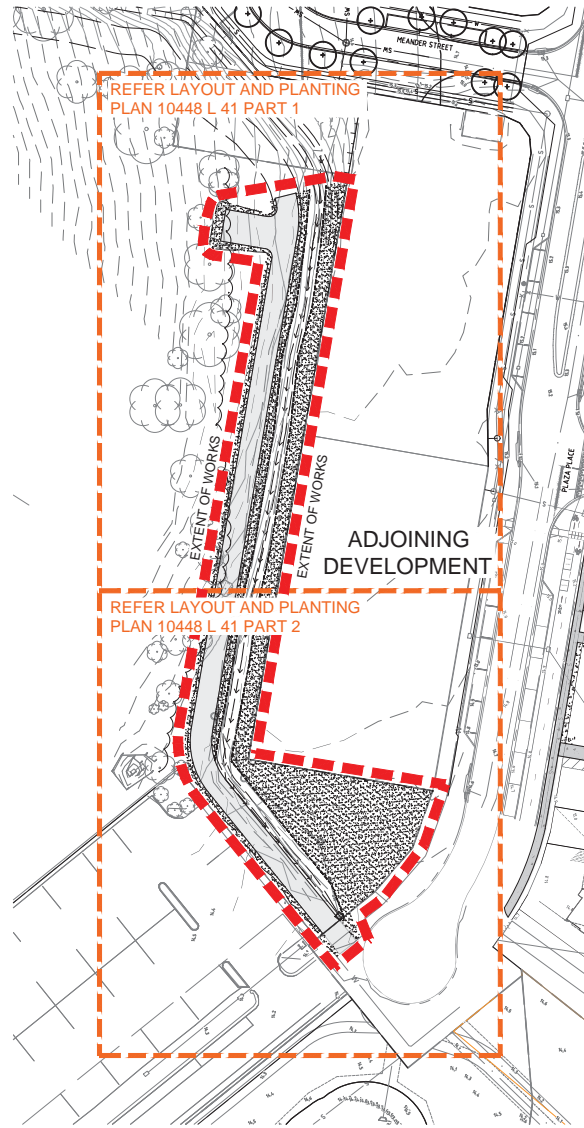

**STAGE LAYOUT PLAN**  
SCALE: 1:500 @ A1

PLANS AND DOCUMENTS referred to in the PDA DEVELOPMENT APPROVAL

Approval no: DEV2022/1329  
Date: 16 December 2022



**DISCLAIMER:** DESIGNS DOCUMENTED ON THIS DRAWING ARE THE PROPERTY OF SAUNDERS HAVILL GROUP PTY LTD AND ARE NOT AUTHORISED FOR REPRODUCTION OR USE IN WHOLE OR PART WITHOUT WRITTEN PERMISSION. THESE PLANS HAVE BEEN PREPARED FOR THE EXCLUSIVE USE OF THE CLIENT. SAUNDERS HAVILL GROUP DO NOT ACCEPT RESPONSIBILITY FOR ANY USE OF OR RELIANCE UPON THE CONTENTS OF THESE DRAWINGS BY ANY THIRD PARTY. CONFIRM ALL DIMENSIONS ON SITE AND CLARIFY ANY DISCREPANCIES PRIOR TO CONSTRUCTION.



 SCALE: AS NOTED

| AMENDMENTS: | ISSUE      | DATE                       | DESCRIPTION | CHECKED |
|-------------|------------|----------------------------|-------------|---------|
| A           | 22.06.2022 | CLIENT ISSUE               | CT          |         |
| B           | 01.07.2022 | COUNCIL SUBMISSION ISSUE   | RM          |         |
| C           | 01.07.2022 | REVISED COUNCIL SUBMISSION | RM          |         |

CLIENT: ECONOMIC DEVELOPMENT QUEENSLAND

PROJECT: CARSELDINE VILLAGE BEAMS RD, CARSELDINE CATCH DRAIN - PHASE 1



DRAWING: LANDSCAPE COVER SHEET

DRAWN: FW/CT CHECKED: RM

DRAWING #: 10448 L 40 C





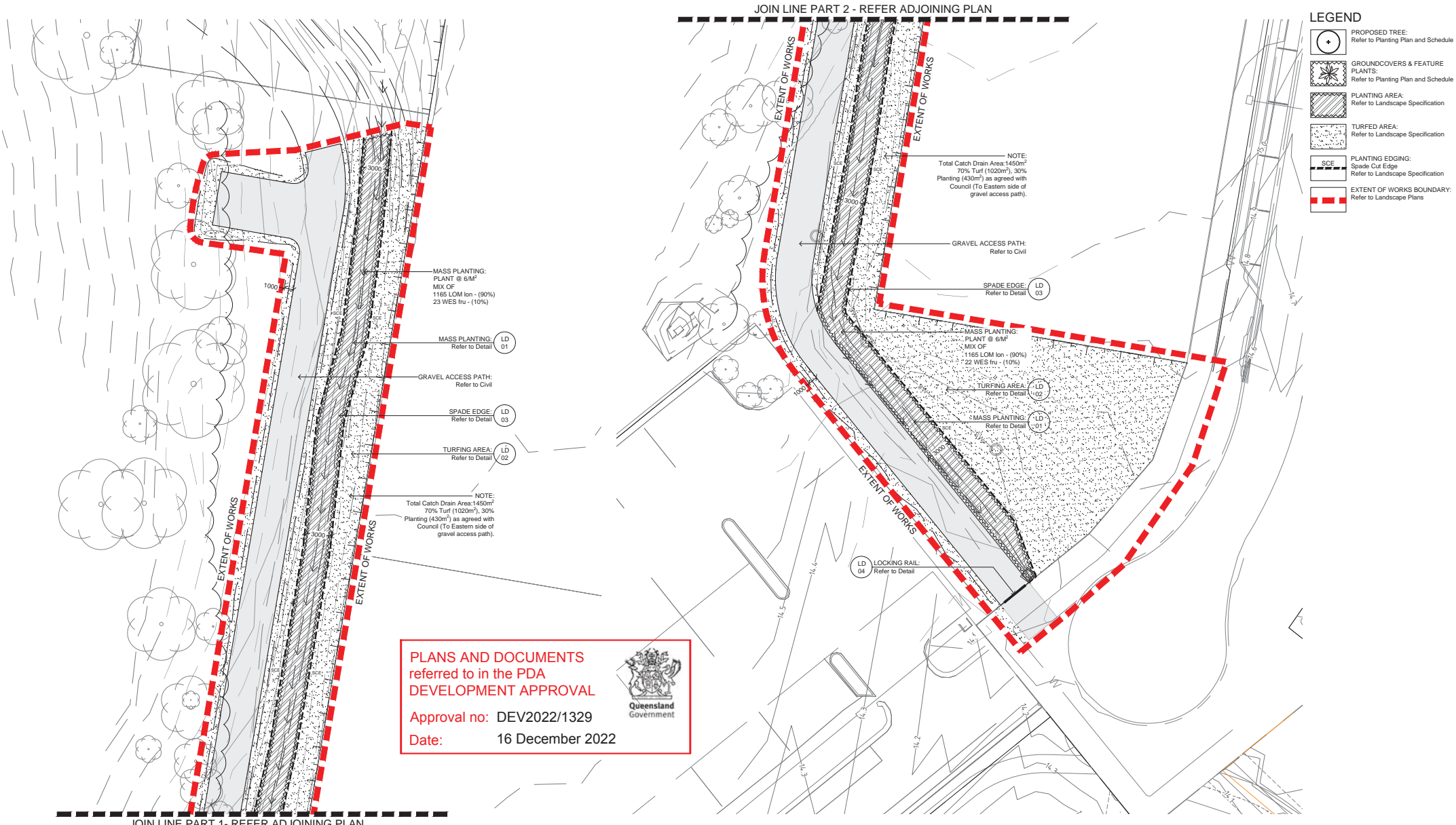

**SH saunders havill group**  
LANDSCAPE ARCHITECTURE  
9 THOMPSON STREET, BOWEN HILLS QLD 4006  
PHONE: 1300 123 SHG WWW.SAUNDERSHAVILL.COM



J:\10448 Beams Road, Carlseldine (EOD)\Working Files\AvecCAD\L - Landscape\Drainage\Catch10-448 L 41 - Layout Plan Sheet 1.dwg



**LEGEND**

-  PROPOSED TREE:  
Refer to Planting Plan and Schedule
-  GROUNDCOVERS & FEATURE PLANTS:  
Refer to Planting Plan and Schedule
-  PLANTING AREA:  
Refer to Landscape Specification
-  TURFED AREA:  
Refer to Landscape Specification
-  PLANTING EDGING:  
Spade Cut Edge  
Refer to Landscape Specification
-  EXTENT OF WORKS BOUNDARY:  
Refer to Landscape Plans

**PLANS AND DOCUMENTS**  
 referred to in the PDA  
**DEVELOPMENT APPROVAL**  
 Approval no: DEV2022/1329  
 Date: 16 December 2022



**DISCLAIMER:** DESIGNS DOCUMENTED ON THIS DRAWING ARE THE PROPERTY OF SAUNDERS HAVILL GROUP PTY LTD AND ARE NOT AUTHORISED FOR REPRODUCTION OR USE IN WHOLE OR PART WITHOUT WRITTEN PERMISSION. THESE PLANS HAVE BEEN PREPARED FOR THE EXCLUSIVE USE OF THE CLIENT. SAUNDERS HAVILL GROUP DO NOT ACCEPT RESPONSIBILITY FOR ANY USE OF OR RELIANCE UPON THE CONTENTS OF THESE DRAWINGS BY ANY THIRD PARTY. CONFIRM ALL DIMENSIONS ON SITE AND CLARIFY ANY DISCREPANCIES PRIOR TO CONSTRUCTION.

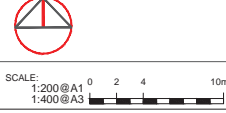
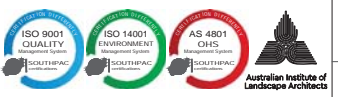

| AMENDMENTS: | ISSUE DATE | DESCRIPTION                | CHECKED |
|-------------|------------|----------------------------|---------|
| A           | 22.06.2022 | CLIENT ISSUE               | RM      |
| B           | 01.07.2022 | COUNCIL SUBMISSION ISSUE   | RM      |
| C           | 01.07.2022 | REVISED COUNCIL SUBMISSION | RM      |

CLIENT: ECONOMIC DEVELOPMENT QUEENSLAND

PROJECT: CARSELDINE VILLAGE BEAMS RD, CARSELDINE CATCH DRAIN - PHASE 1

DRAWING: LANDSCAPE LAYOUT PLAN AND PLANTING PLAN  
 DRAWN: FW/CT CHECKED: RM  
 DRAWING #: 10448 L 41 C



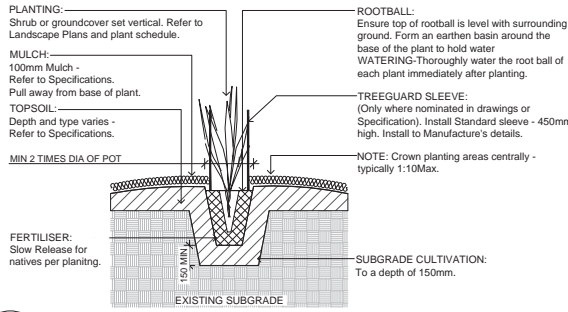

**LD 01 MASS PLANTING DETAIL**  
SCALE: 1:20 @ A1

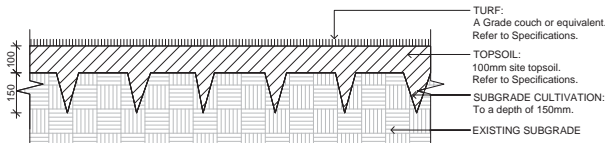

**LD 02 TURFING DETAIL**  
SCALE: 1:10 @ A1

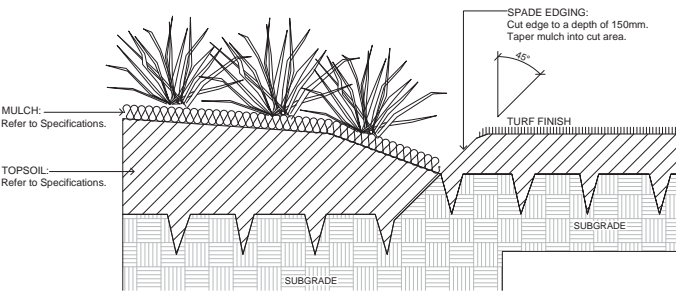

**LD 03 SPADE CUT EDGE DETAIL**  
SCALE: 1:10 @ A1

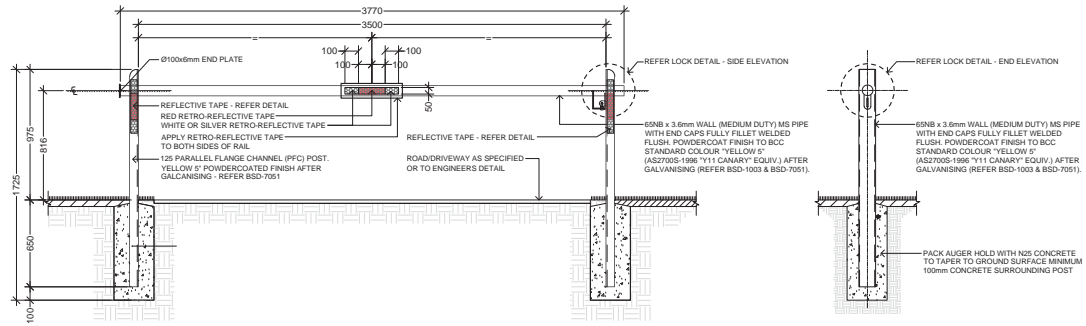

**ELEVATION**  
SCALE: 1:20 @ A1

**SECTION ELEVATION A-A**  
SCALE: 1:20 @ A1



**PLAN VIEW**  
SCALE: 1:20 @ A1

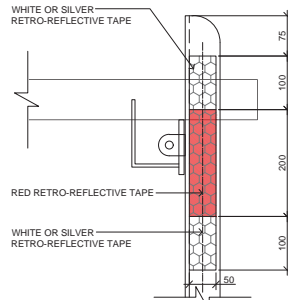

**REFLECTIVE TAPE DETAIL**  
SCALE: 1:5 @ A1  
APPLY TO BOTH SIDE OF POST

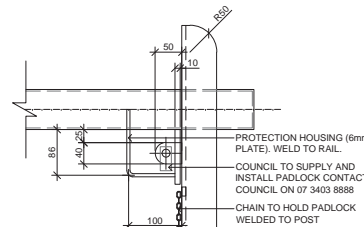

**LOCK DETAIL - END ELEVATION**  
SCALE: 1:5 @ A1

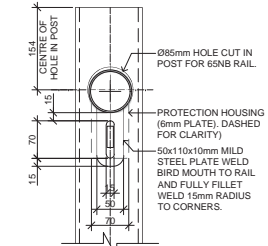

**LOCK DETAIL - SIDE ELEVATION**  
SCALE: 1:5 @ A1

**LD 04 ENTRANCE BARRIER - LOCKRAIL WITH STEEL POSTS - (BSD-7054)**

**10448 - CARSELDINE VILLAGE, CARSELDINE  
CATCH DRAINAGE - PHASE 1 PLANT SCHEDULE**

| CODE                 | SPECIES              | COMMON NAME         | SIZE      | QTY  | HEIGHT (Min.) | SPREAD (Min.) | STAKING | TRUNK CALIPER |
|----------------------|----------------------|---------------------|-----------|------|---------------|---------------|---------|---------------|
| <b>GROUND COVERS</b> |                      |                     |           |      |               |               |         |               |
| LOM lon              | LOMANDRA longifolia  | Long-leaved Matrush | TUBESTOCK | 2330 | 300mm         | 150mm         | No      | N/A           |
| WES fru              | WESTRINGIA fruticosa | Coast Rosemary      | TUBESTOCK | 45   | 300mm         | 150mm         | No      | N/A           |

**PLANT SCHEDULE**

PLANS AND DOCUMENTS referred to in the PDA DEVELOPMENT APPROVAL



Approval no: DEV2022/1329

Date: 16 December 2022

J:\10448 Beams Road, Careldine (EOD)\Working Files\AutoCAD\L - Landscape\Drawings\Catch10448\_L\_42 - Construction Details Sheet 1.dwg

**DISCLAIMER:** DESIGNS DOCUMENTED ON THIS DRAWING ARE THE PROPERTY OF SAUNDERS HAVILL GROUP PTY LTD AND ARE NOT AUTHORISED FOR REPRODUCTION OR USE IN WHOLE OR PART WITHOUT WRITTEN PERMISSION. THESE PLANS HAVE BEEN PREPARED FOR THE EXCLUSIVE USE OF THE CLIENT. SAUNDERS HAVILL GROUP DO NOT ACCEPT RESPONSIBILITY FOR ANY USE OF OR RELIANCE UPON THE CONTENTS OF THESE DRAWINGS BY ANY THIRD PARTY. CONFIRM ALL DIMENSIONS ON SITE AND CLARIFY ANY DISCREPANCIES PRIOR TO CONSTRUCTION.



SCALE: AS NOTED

| AMENDMENTS: | ISSUE DATE | DESCRIPTION                | CHECKED |
|-------------|------------|----------------------------|---------|
| A           | 22.06.2022 | CLIENT ISSUE               | RM      |
| B           | 01.07.2022 | COUNCIL SUBMISSION ISSUE   | RM      |
| C           | 01.07.2022 | REVISED COUNCIL SUBMISSION | RM      |

CLIENT: ECONOMIC DEVELOPMENT QUEENSLAND

PROJECT: CARSELDINE VILLAGE BEAMS RD, CARSELDINE CATCH DRAIN - PHASE 1

DRAWING: LANDSCAPE CONSTRUCTION DETAILS

DRAWN: FW/CT CHECKED: RM

DRAWING #: 10448 L 42 C



# CARSELDINE VILLAGE BEAMS ROAD, CARSELDINE - CATCH DRAIN - PHASE 2

## LANDSCAPE DOCUMENTATION

ISSUE A 27.07.2022

CLIENT ISSUE

DRAWING SCHEDULE

| DWG NO.    | DRAWING TITLE                      | ISSUE | DATE       |
|------------|------------------------------------|-------|------------|
| 10448 L 50 | LANDSCAPE COVER SHEET              | A     | 27.07.2022 |
| 10448 L 51 | LANDSCAPE LAYOUT AND PLANTING PLAN | A     | 27.07.2022 |
| 10448 L 52 | LANDSCAPE CONSTRUCTION DETAILS     | A     | 27.07.2022 |

PLANS AND DOCUMENTS  
referred to in the PDA  
DEVELOPMENT APPROVAL

Approval no: DEV2022/1329

Date: 16 December 2022



Queensland  
Government

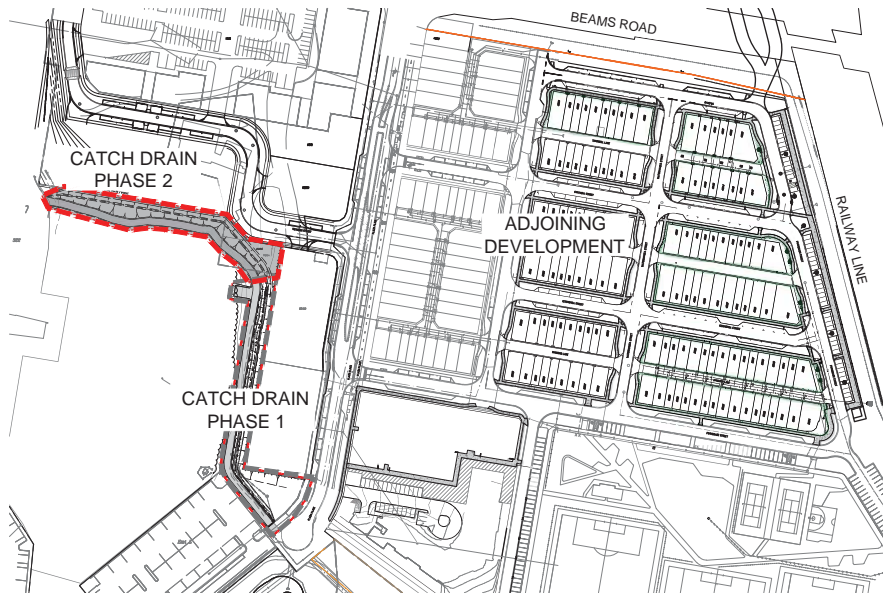
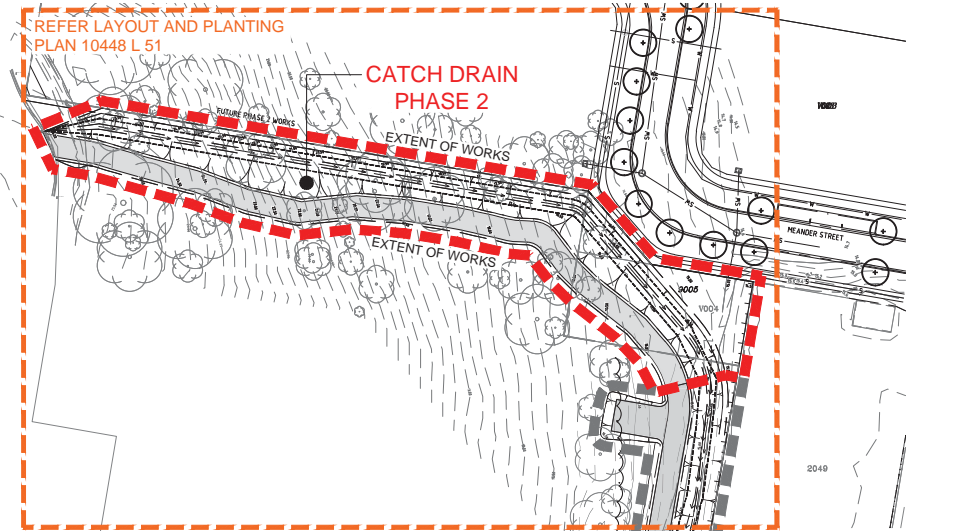

SITE LAYOUT PLAN  
SCALE: 1:1500 @ A1

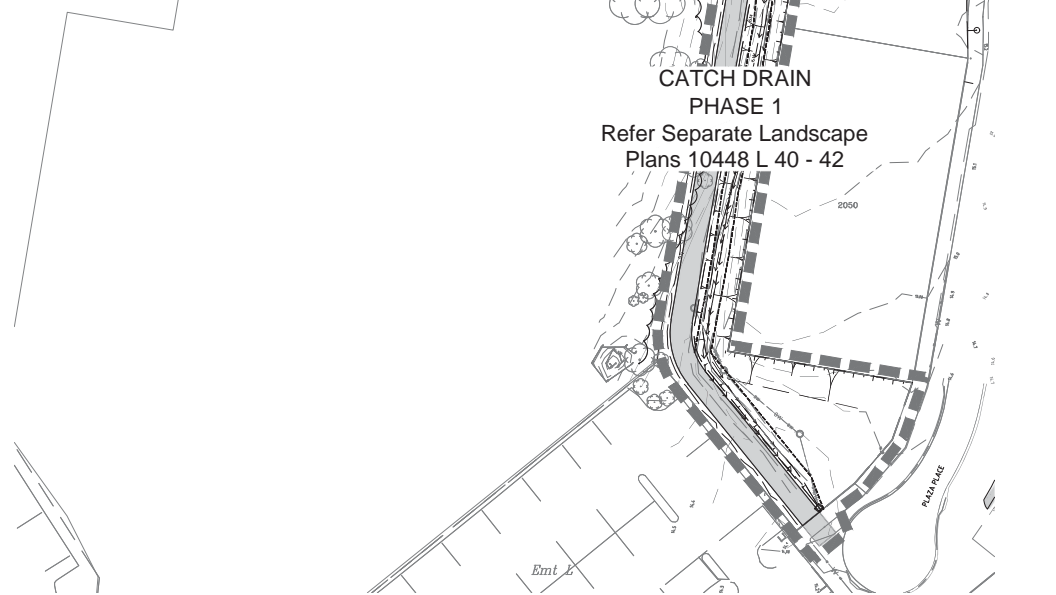

STAGE LAYOUT PLAN  
SCALE: 1:500 @ A1

DISCLAIMER: DESIGNS DOCUMENTED ON THIS DRAWING ARE THE PROPERTY OF SAUNDERS HAVILL GROUP PTY LTD AND ARE NOT AUTHORISED FOR REPRODUCTION OR USE IN WHOLE OR PART WITHOUT WRITTEN PERMISSION. THESE PLANS HAVE BEEN PREPARED FOR THE EXCLUSIVE USE OF THE CLIENT. SAUNDERS HAVILL GROUP DO NOT ACCEPT RESPONSIBILITY FOR ANY USE OF OR RELIANCE UPON THE CONTENTS OF THESE DRAWINGS BY ANY THIRD PARTY. CONFIRM ALL DIMENSIONS ON SITE AND CLARIFY ANY DISCREPANCIES PRIOR TO CONSTRUCTION.



Australian Institute of  
Landscape Architects

SCALE:  
AS NOTED

| AMENDMENTS: | ISSUE | DATE       | DESCRIPTION  | CHECKED |
|-------------|-------|------------|--------------|---------|
|             | A     | 27.07.2022 | CLIENT ISSUE | RM      |

CLIENT: ECONOMIC DEVELOPMENT  
QUEENSLAND

PROJECT: CARSELDINE VILLAGE  
BEAMS RD, CARSELDINE  
CATCH DRAIN - PHASE 2



DRAWING: LANDSCAPE  
COVER SHEET

DRAWN: FW/CT CHECKED: RM

DRAWING #: 10448 L 50 A

**SH saunders  
havill  
group**  
LANDSCAPE ARCHITECTURE  
9 THOMPSON STREET, BOWEN HILLS QLD 4006  
PHONE 1300 123 SHG WWW.SAUNDERSHAVILL.COM

J:\10448 Beams Road, Carlsdine (EOD)\Working Files\AutoCAD\1 - Landscape\Drainage CatchPhase 2\10448 L 51 - Layout Plan Sheet 1.dwg

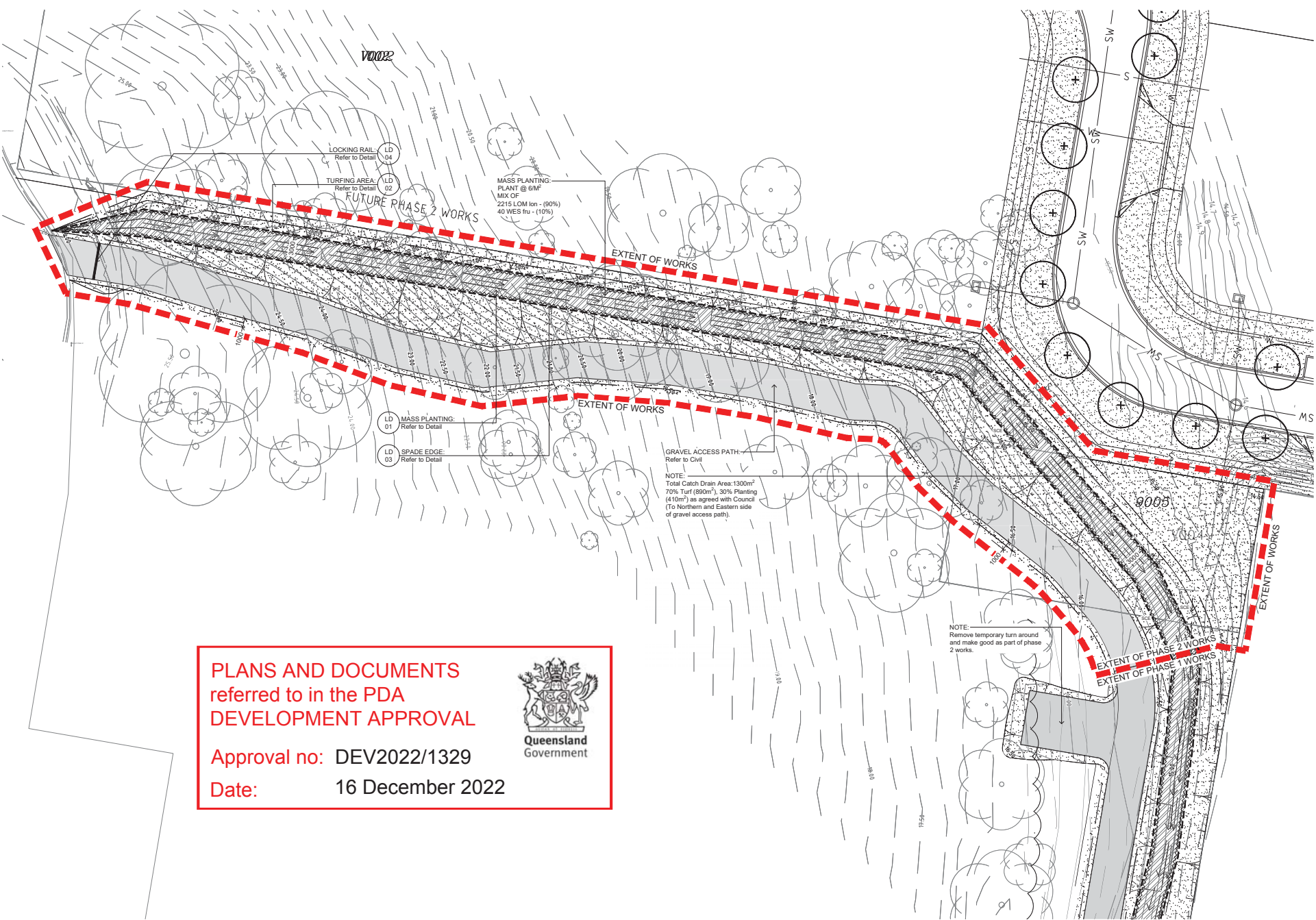

- LEGEND**
- PROPOSED TREE:  
Refer to Planting Plan and Schedule
  - GROUNDCOVERS & FEATURE PLANTS:  
Refer to Planting Plan and Schedule
  - PLANTING AREA:  
Refer to Landscape Specification
  - TURFED AREA:  
Refer to Landscape Specification
  - PLANTING EDGING:  
Spade Cut Edge  
Refer to Landscape Specification
  - EXTENT OF WORKS BOUNDARY:  
Refer to Landscape Plans

**PLANS AND DOCUMENTS referred to in the PDA DEVELOPMENT APPROVAL**

Approval no: DEV2022/1329  
Date: 16 December 2022

Queensland Government

**DISCLAIMER:** DESIGNS DOCUMENTED ON THIS DRAWING ARE THE PROPERTY OF SAUNDERS HAVILL GROUP PTY LTD AND ARE NOT AUTHORISED FOR REPRODUCTION OR USE IN WHOLE OR PART WITHOUT WRITTEN PERMISSION. THESE PLANS HAVE BEEN PREPARED FOR THE EXCLUSIVE USE OF THE CLIENT. SAUNDERS HAVILL GROUP DO NOT ACCEPT RESPONSIBILITY FOR ANY USE OF OR RELIANCE UPON THE CONTENTS OF THESE DRAWINGS BY ANY THIRD PARTY. CONFIRM ALL DIMENSIONS ON SITE AND CLARIFY ANY DISCREPANCIES PRIOR TO CONSTRUCTION.

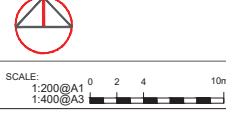

| AMENDMENTS: | ISSUE: | DATE:      | DESCRIPTION: | CHECKED: |
|-------------|--------|------------|--------------|----------|
|             | A      | 27.07.2022 | CLIENT ISSUE | RM       |
|             |        |            |              |          |
|             |        |            |              |          |

CLIENT: ECONOMIC DEVELOPMENT QUEENSLAND

PROJECT: CARSELDINE VILLAGE BEAMS RD, CARSELDINE CATCH DRAIN - PHASE 2

DRAWING: LANDSCAPE LAYOUT PLAN AND PLANTING PLAN

DRAWN: FW/CT      CHECKED: RM

DRAWING #: 10448 L 51 A

**saunders havill group**  
LANDSCAPE ARCHITECTURE  
9 THOMPSON STREET, BOWEN HILLS QLD 4008  
PHONE 1300 123 SHG WWW.SAUNDERSHAVILL.COM

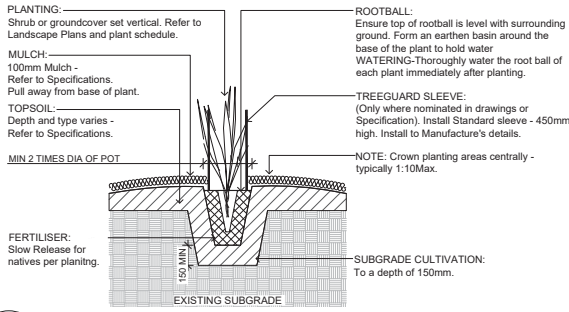

**LD 01 MASS PLANTING DETAIL**  
SCALE: 1:20 @ A1

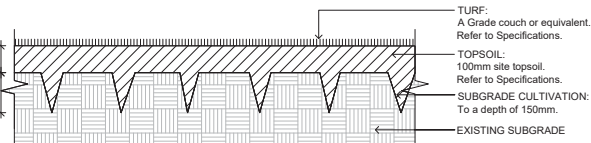

**LD 02 TURFING DETAIL**  
SCALE: 1:10 @ A1

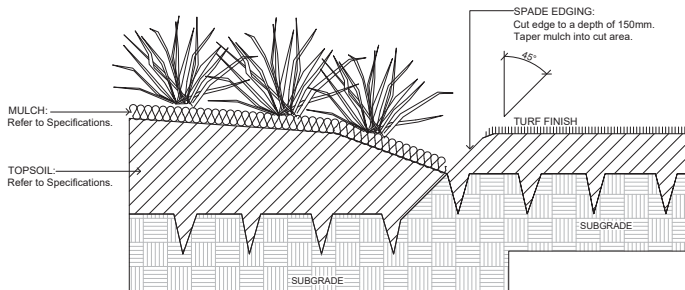

**LD 03 SPADE CUT EDGE DETAIL**  
SCALE: 1:10 @ A1

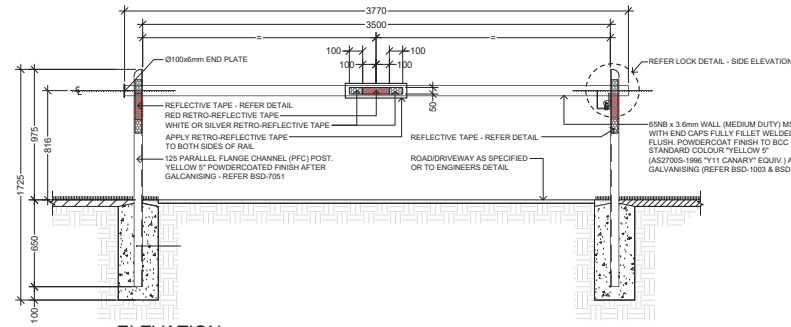

**ELEVATION**  
SCALE: 1:20 @ A1

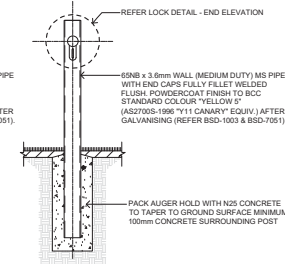

**SECTION ELEVATION A-A**  
SCALE: 1:20 @ A1

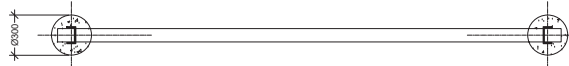

**PLAN VIEW**  
SCALE: 1:20 @ A1

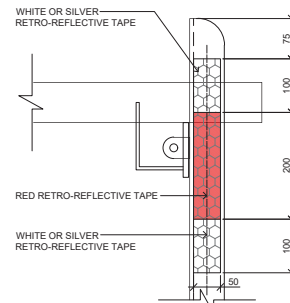

**REFLECTIVE TAPE DETAIL**  
SCALE: 1:5 @ A1  
APPLY TO BOTH SIDE OF POST

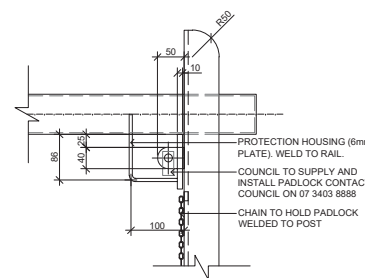

**LOCK DETAIL - END ELEVATION**  
SCALE: 1:5 @ A1

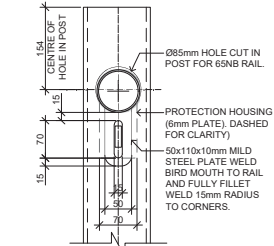

**LOCK DETAIL - SIDE ELEVATION**  
SCALE: 1:5 @ A1

**LD 04 ENTRANCE BARRIER - LOCKRAIL WITH STEEL POSTS - (BSD-7054)**

**10448 - CARSELDINE VILLAGE, CARSELDINE  
CATCH DRAINAGE - PHASE 2 PLANT SCHEDULE**

| CODE                 | SPECIES              | COMMON NAME         | SIZE      | QTY  | HEIGHT (Min.) | SPREAD (Min.) | STAKING | TRUNK CALIPER |
|----------------------|----------------------|---------------------|-----------|------|---------------|---------------|---------|---------------|
| <b>GROUND COVERS</b> |                      |                     |           |      |               |               |         |               |
| LOM lon              | LOMANDRA longifolia  | Long-leaved Matrush | TUBESTOCK | 2215 | 300mm         | 150mm         | No      | N/A           |
| WES fu               | WESTRINGIA fruticosa | Coast Rosemary      | TUBESTOCK | 40   | 300mm         | 150mm         | No      | N/A           |

**PLANT SCHEDULE**

**PLANS AND DOCUMENTS  
referred to in the PDA  
DEVELOPMENT APPROVAL**



Queensland  
Government

Approval no: DEV2022/1329

Date: 16 December 2022

**DISCLAIMER:** DESIGNS DOCUMENTED ON THIS DRAWING ARE THE PROPERTY OF SAUNDERS HAVILL GROUP PTY LTD AND ARE NOT AUTHORISED FOR REPRODUCTION OR USE IN WHOLE OR PART WITHOUT WRITTEN PERMISSION. THESE PLANS HAVE BEEN PREPARED FOR THE EXCLUSIVE USE OF THE CLIENT. SAUNDERS HAVILL GROUP DO NOT ACCEPT RESPONSIBILITY FOR ANY USE OF OR RELIANCE UPON THE CONTENTS OF THESE DRAWINGS BY ANY THIRD PARTY. CONFIRM ALL DIMENSIONS ON SITE AND CLARIFY ANY DISCREPANCIES PRIOR TO CONSTRUCTION.



SCALE: AS NOTED

| AMENDMENTS: | ISSUE: | DATE:      | DESCRIPTION: | CHECKED: |
|-------------|--------|------------|--------------|----------|
| A           | 1      | 27.07.2022 | CLIENT ISSUE | RM       |

CLIENT: ECONOMIC DEVELOPMENT  
QUEENSLAND

PROJECT: CARSELDINE VILLAGE  
BEAMS RD, CARSELDINE  
CATCH DRAIN - PHASE 2



DRAWING: **LANDSCAPE  
CONSTRUCTION  
DETAILS**

DRAWN: FW/CT CHECKED: RM

DRAWING #: **10448 L 52 A**

**SH saunders  
havill  
group**  
LANDSCAPE ARCHITECTURE  
9 THOMPSON STREET, BOWEN HILLS QLD 4008  
PHONE 1300 123 SHG WWW.SAUNDERSHAVILL.COM

# CARSELDINE URBAN VILLAGE



STAGE 1

FOR ECONOMIC DEVELOPMENT QUEENSLAND



LOCALITY PLAN  
N.T.S



## DRAWING INDEX

### GENERAL

1000 COVER SHEET AND DRAWING INDEX

### BULK EARTHWORKS

1200 BULK EARTHWORKS LAYOUT PLAN SHEET 1 OF 5  
1201 BULK EARTHWORKS LAYOUT PLAN SHEET 2 OF 5  
1202 BULK EARTHWORKS LAYOUT PLAN SHEET 3 OF 5  
1203 BULK EARTHWORKS LAYOUT PLAN SHEET 4 OF 5  
1204 BULK EARTHWORKS LAYOUT PLAN SHEET 5 OF 5  
1210 BULK EARTHWORKS SECTIONS  
1225 LOT EARTHWORKS LAYOUT PLAN SHEET 1 OF 2  
1226 LOT EARTHWORKS LAYOUT PLAN SHEET 2 OF 2  
1250 ACOUSTIC FENCE LAYOUT PLAN SHEET 1 OF 2  
1251 ACOUSTIC FENCE LAYOUT PLAN SHEET 2 OF 2  
1252 ACOUSTIC FENCE DETAILS  
1253 BLOCKWORK RETAINING WALL DETAILS  
1254 CONCRETE SLEEPER RETAINING WALL DETAIL

### ROADWORKS

1300 CONTROL LINE LAYOUT PLAN SHEET 1 OF 2  
1301 CONTROL LINE LAYOUT PLAN SHEET 2 OF 2  
1302 CONTROL LINE SETOUT TABLES  
1310 ROADWORKS LAYOUT PLAN SHEET 1 OF 2  
1311 ROADWORKS LAYOUT PLAN SHEET 2 OF 2  
1320 ROADWORKS INTERSECTION DETAILS SHEET 1 OF 4  
1321 ROADWORKS INTERSECTION DETAILS SHEET 2 OF 4  
1322 ROADWORKS INTERSECTION DETAILS SHEET 3 OF 4  
1323 ROADWORKS INTERSECTION DETAILS SHEET 4 OF 4  
1330 ROAD 01-ROAD11 LONGITUDINAL SECTION  
1331 ROAD 01 CROSS SECTIONS SHEET 1 OF 2  
1332 ROAD 01 CROSS SECTIONS SHEET 2 OF 2  
1333 ROAD 05 LONGITUDINAL SECTION AND CROSS SECTIONS  
1334 ROAD 06 LONGITUDINAL SECTION  
1335 ROAD 06 CROSS SECTIONS  
1336 ROAD 12 LONGITUDINAL SECTION AND CROSS SECTIONS  
1337 LANE 01 LONGITUDINAL SECTION AND CROSS SECTIONS  
1338 LANE 02 LONGITUDINAL SECTION AND CROSS SECTIONS  
1339 LANE 03 LONGITUDINAL SECTION AND CROSS SECTIONS  
1340 LANE 04 LONGITUDINAL SECTION AND CROSS SECTIONS  
1341 LANE 05 LONGITUDINAL SECTION AND CROSS SECTIONS  
1342 ROAD 07 LONGITUDINAL SECTION AND CROSS SECTIONS  
1350 SIGNAGE AND LINEMARKING LAYOUT PLAN SHEET 1 OF 3  
1351 SIGNAGE AND LINEMARKING LAYOUT PLAN SHEET 2 OF 3  
1352 SIGNAGE AND LINEMARKING LAYOUT PLAN SHEET 3 OF 3  
1360 PAVEMENT DETAILS LAYOUT PLAN SHEET 1 OF 2  
1361 PAVEMENT DETAILS LAYOUT PLAN SHEET 2 OF 2  
1370 JOINTING DETAIL LAYOUT PLAN SHEET 1 OF 2  
1371 JOINTING DETAIL LAYOUT PLAN SHEET 2 OF 2  
1372 JOINTING DETAILS

### STORMWATER DRAINAGE

1400 STORMWATER DRAINAGE LAYOUT PLAN SHEET 1 OF 6  
1401 STORMWATER DRAINAGE LAYOUT PLAN SHEET 2 OF 6  
1402 STORMWATER DRAINAGE LAYOUT PLAN SHEET 3 OF 6  
1403 STORMWATER DRAINAGE LAYOUT PLAN SHEET 4 OF 6  
1404 STORMWATER DRAINAGE LAYOUT PLAN SHEET 5 OF 6  
1405 STORMWATER DRAINAGE LAYOUT PLAN SHEET 6 OF 6  
1406 STORMWATER DRAINAGE NOTES AND DETAILS SHEET  
1410 STORMWATER DRAINAGE CATCHMENT PLAN SHEET 1 OF 2  
1411 STORMWATER DRAINAGE CATCHMENT PLAN SHEET 2 OF 2  
1412 STORMWATER DRAINAGE EXTERNAL CATCHMENT PLAN

## DRAWING INDEX

1420 STORMWATER DRAINAGE LONGITUDINAL SECTIONS SHEET 1 OF 6  
1421 STORMWATER DRAINAGE LONGITUDINAL SECTIONS SHEET 2 OF 6  
1422 STORMWATER DRAINAGE LONGITUDINAL SECTIONS SHEET 3 OF 6  
1423 STORMWATER DRAINAGE LONGITUDINAL SECTIONS SHEET 4 OF 6  
1424 STORMWATER DRAINAGE LONGITUDINAL SECTIONS SHEET 5 OF 6  
1425 STORMWATER DRAINAGE LONGITUDINAL SECTIONS SHEET 6 OF 6  
1426 STORMWATER DRAINAGE OPEN CHANNEL SECTIONS  
1430 STORMWATER DRAINAGE MINOR CALCULATION TABLES SHEET 1 OF 6  
1431 STORMWATER DRAINAGE MINOR CALCULATION TABLES SHEET 2 OF 6  
1432 STORMWATER DRAINAGE MINOR CALCULATION TABLES SHEET 3 OF 6  
1433 STORMWATER DRAINAGE MAJOR CALCULATION TABLES SHEET 4 OF 6  
1434 STORMWATER DRAINAGE MAJOR CALCULATION TABLES SHEET 5 OF 6  
1435 STORMWATER DRAINAGE MAJOR CALCULATION TABLES SHEET 6 OF 6  
1440 STORMWATER DRAINAGE STRUCTURE DETAILS SHEET 1 OF 12  
1441 STORMWATER DRAINAGE STRUCTURE DETAILS SHEET 2 OF 12  
1442 STORMWATER DRAINAGE STRUCTURE DETAILS SHEET 3 OF 12  
1443 STORMWATER DRAINAGE STRUCTURE DETAILS SHEET 4 OF 12  
1444 STORMWATER DRAINAGE STRUCTURE DETAILS SHEET 5 OF 12  
1445 STORMWATER DRAINAGE STRUCTURE DETAILS SHEET 6 OF 12  
1446 STORMWATER DRAINAGE STRUCTURE DETAILS SHEET 7 OF 12  
1447 STORMWATER DRAINAGE STRUCTURE DETAILS SHEET 8 OF 12  
1448 STORMWATER DRAINAGE STRUCTURE DETAILS SHEET 9 OF 12  
1449 STORMWATER DRAINAGE STRUCTURE DETAILS SHEET 10 OF 12  
1450 STORMWATER DRAINAGE STRUCTURE DETAILS SHEET 11 OF 12  
1451 STORMWATER DRAINAGE STRUCTURE DETAILS SHEET 12 OF 12  
1452 STORMWATER DRAINAGE STRUCTURE DETAILS TYPICAL DETAILS AND NOTES  
1453 STORMWATER DRAINAGE STRUCTURE DETAILS TYPICAL DETAILS

### SEWER RETICULATION

1500 SEWER RETICULATION NOTES AND DETAILS  
1510 SEWER RETICULATION LAYOUT PLAN SHEET 1 OF 3  
1511 SEWER RETICULATION LAYOUT PLAN SHEET 2 OF 3  
1512 SEWER RETICULATION LAYOUT PLAN SHEET 3 OF 3  
1520 SEWER RETICULATION LONGITUDINAL SECTIONS SHEET 1 OF 4  
1521 SEWER RETICULATION LONGITUDINAL SECTIONS SHEET 2 OF 4  
1522 SEWER RETICULATION LONGITUDINAL SECTIONS SHEET 3 OF 4  
1523 SEWER RETICULATION LONGITUDINAL SECTIONS SHEET 4 OF 4  
1524 SEWER RETICULATION TUNNEL BORE AND CONNECTION DETAILS  
1525 SEWER RETICULATION STRUCTURAL MANHOLE DETAILS

### WATER RETICULATION

1600 WATER RETICULATION NOTES EARLY WORKS  
1601 WATER RETICULATION LAYOUT PLAN EARLY WORKS  
1610 WATER RETICULATION DETAILS SHEET 1 OF 2  
1611 WATER RETICULATION DETAILS SHEET 2 OF 2  
1612 WATER RETICULATION DETAILS AND SECTIONS  
1650 WATER RETICULATION NOTES  
1651 WATER RETICULATION LAYOUT PLAN SHEET 1 OF 2  
1652 WATER RETICULATION LAYOUT PLAN SHEET 2 OF 2

### EXISTING SERVICES

1900 EXISTING SERVICES WATER RETICULATION  
1901 EXISTING SERVICES STORMWATER RETICULATION  
1902 EXISTING SERVICES SEWERAGE RETICULATION  
1903 EXISTING SERVICES ELECTRICAL UNDERGROUND  
1904 EXISTING SERVICES COMMUNICATION

### ROAD FUNCTIONAL

RF1 ROAD FUNCTIONAL LAYOUT PLAN SHEET 1 OF 2  
RF2 ROAD FUNCTIONAL LAYOUT PLAN SHEET 2 OF 2

## DESIGN FLOW DRAWING INDEX

| PROJECT No | DRAWING No | DESCRIPTION   |
|------------|------------|---|
| 4306       | D-S-0001   | BIORETENTION BASIN 2 - STAGE 1 - GENERAL LAYOUT AND DRAWING LIST              |
| 4306       | D-S-0002   | BIORETENTION BASIN 2 - STAGE 1 - CONSTRUCTION NOTES                           |
| 4306       | D-S-0101   | BIORETENTION BASIN 2 - STAGE 1 - PLAN   |
| 4306       | D-S-0102   | BIORETENTION BASIN 2 - STAGE 1 - EARTHWORKS SECTIONS                          |
| 4306       | D-S-0201   | BIORETENTION BASIN 2 - STAGE 1 - HYDRAULIC SECTIONS                           |
| 4306       | D-S-0202   | BIORETENTION BASIN 2 - STAGE 1 - HYDRAULIC STRUCTURES DETAILS - SHEET 1 OF 2  |
| 4306       | D-S-0203   | BIORETENTION BASIN 2 - STAGE 1 - HYDRAULIC STRUCTURES DETAILS - SHEET 2 OF 2  |
| 4306       | D-S-0301   | BIORETENTION BASIN 2 - STAGE 1 - BIORETENTION TYPICAL DETAILS - SHEET 1 OF 2  |
| 4306       | D-S-0302   | BIORETENTION BASIN 2 - STAGE 1 - BIORETENTION TYPICAL DETAILS - SHEET 2 OF 2  |
| 4306       | D-S-0401   | BIORETENTION BASIN 2 - STAGE 1 - BIORETENTION SURFACES AND PLANTING SCHEDULES |

**NOTE:**  
DESIGN FLOW DRAWINGS MUST BE READ IN CONJUNCTION  
WITH CALIBRE PROFESSIONAL SERVICES 15-003002.01  
PROJECT DRAWINGS

**BRISBANE CITY COUNCIL SURVEYOR**  
AREA OF SITE: 3.51 ha LAND PARTNERS

## CONSTRUCTION NOTE

THESE DRAWINGS ARE TO BE READ IN CONJUNCTION WITH:

- ACID SULPHATES SOILS REPORT (PREPARED BY GALLAGHER ENVIRONMENTAL - GE20.025.L1)
- GEOTECHNICAL REPORT (PREPARED BY SGS - SGS/17/E184B 29 MAY 2018)
- FLORA FAUNA MANAGEMENT PLAN (FFMP) (PREPARED BY 28 SOUTH)
- DISPERSIVE SOILS MANAGEMENT PLAN (DSMP) (PREPARED BY GALLAGHER ENVIRONMENTAL - GE20.025.R1)

## CONSTRUCTION HOLD POINT

ONCE THE BASE OF MANHOLES, INSPECTION PITS, GULLIES AND FIELD INLETS FOR STORMWATER DRAINAGE AND SEWER RETICULATION HAVE BEEN POURED, FURTHER CONSTRUCTION SHALL NOT PROCEED UNTIL THE SUPERINTENDENT AND/OR ENGINEER HAVE INSPECTED THE WORKS FOR FINISHED LEVELS AND APPROVED CONSTRUCTION TO CONTINUE.

**CONSTRUCTION HOLD POINT**  
PRIOR TO CONSTRUCTION THE CONTRACTOR SHALL VERIFY LOCATION AND LEVELS OF ALL EXISTING CROSSINGS AND CONNECTION POINTS.

CARSELDINE URBAN VILLAGE  
STAGE 1

PDA. REF NO. DEV2019/1074

|              |        |              |                 |              |           |
|--------------|--------|--------------|-----------------|--------------|-----------|
| Project No.: | Stage: | Milestone:   | Revision Date.: | Drawing No.: | Revision: |
| 15-003002.01 | 1      | FOR APPROVAL | 23/03/21        | 1000         | 7         |

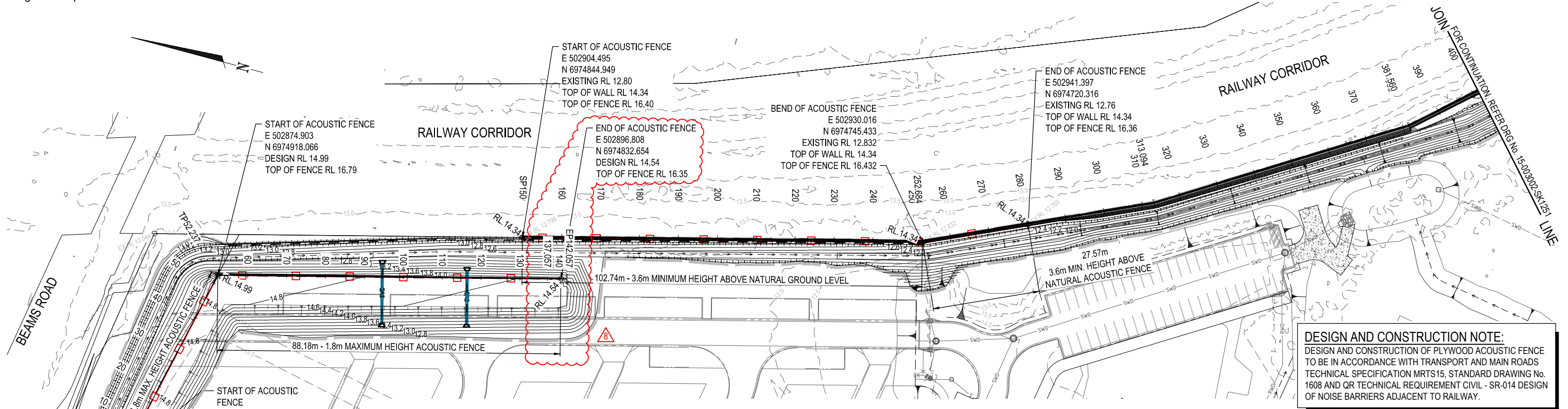

**DESIGN AND CONSTRUCTION NOTE:**  
 DESIGN AND CONSTRUCTION OF PLYWOOD ACOUSTIC FENCE TO BE IN ACCORDANCE WITH TRANSPORT AND MAIN ROADS TECHNICAL SPECIFICATION MRTS15, STANDARD DRAWING No. 1608 AND OR TECHNICAL REQUIREMENT CIVIL - SR-014 DESIGN OF NOISE BARRIERS ADJACENT TO RAILWAY.

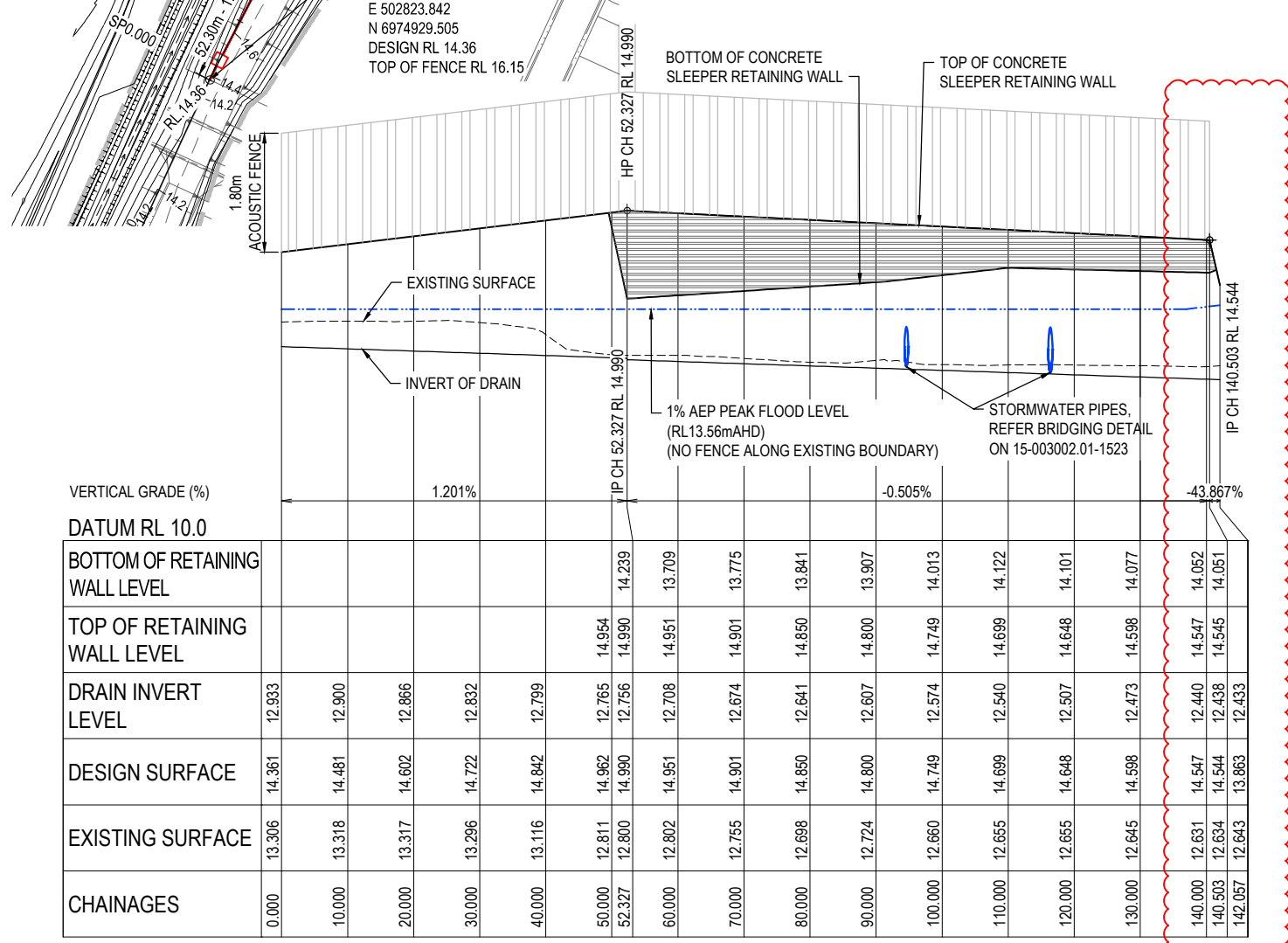

LONGITUDINAL SECTION - EW-ACOUSTIC-FENCE

HORIZ SCALE: 500  
 VERTICAL SCALE: 50

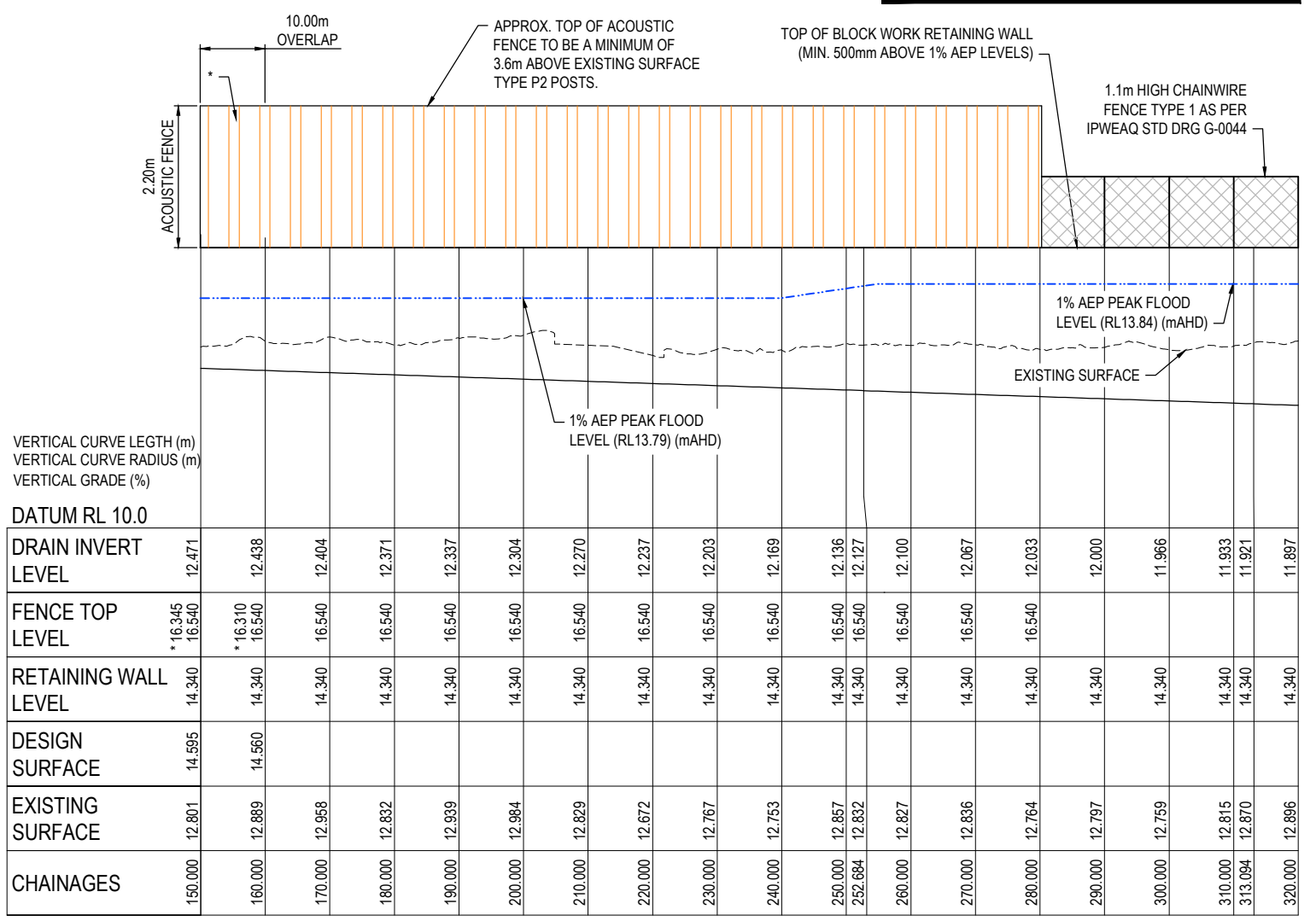

LONGITUDINAL SECTION - EXISTING RAIL BOUNDARY

HORIZ SCALE: 500  
 VERTICAL SCALE: 50

| REVISION | DATE     | ISSUE DETAILS   | DRAWN | DESIGN | DRAWN CHECK | STATUS |
|----------|----------|---|-------|--------|-------------|--------|
| 1        | 1.11.19  | ISSUED FOR APPROVAL   | CHC   | AA     |             |        |
| 2        | 16.04.20 | ACOUSTIC FENCE ALIGNMENT REVISED                              | AA    | AA     | aa          |        |
| 3        | 14.05.20 | ACOUSTIC FENCE AND BLOCK WALL LEVELS REVISED                  | AA    | AA     |             |        |
| 4        | 28.05.20 | RETAINING WALL LEVELS AMENDED                                 | CHC   | DC     |             |        |
| 5        | 25.06.20 | NOTES AMENDED   | CHC   | DC     |             |        |
| 6        | 16.07.20 | ACOUSTIC FENCE CHAINAGES AND LONGITUDINAL SECTION AMENDED     | CHC   | AA     | aa          |        |
| 7        | 21.01.21 | ACOUSTIC FENCE SHIFTED, CONCRETE SLEEPER RETAINING WALL ADDED | AA    | AA     |             |        |
| 8        | 23.03.21 | END OF ACOUSTIC FENCE ADJUSTED                                | AR    | AA     |             |        |

**FOR CONSTRUCTION**

APPROVED  
**LESLIE ROCHE**  
 RPEQ 14843

FOR & ON BEHALF OF CALIBRE PROFESSIONAL SERVICES PTY LTD

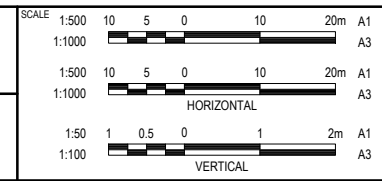

CLIENT  
**ECONOMIC DEVELOPMENT QUEENSLAND**



PROJECT  
**CARSELDINE URBAN VILLAGE STAGE 1**

| DRAWING TITLE                                  |             |          |
|--|-------------|----------|
| <b>ACOUSTIC FENCE LAYOUT PLAN SHEET 1 OF 2</b> |             |          |
| PROJECT No.                                    | DRAWING No. | REVISION |
| 15-003002.01                                   | 1250        | 8        |

PDA. REF No. DEV2019/1074

DISCLAIMER  
 ALL DIMENSIONS TO BE CHECKED ON SITE BY CONTRACTOR PRIOR TO CONSTRUCTION. USE WRITTEN DIMENSIONS ONLY. DO NOT SCALE.

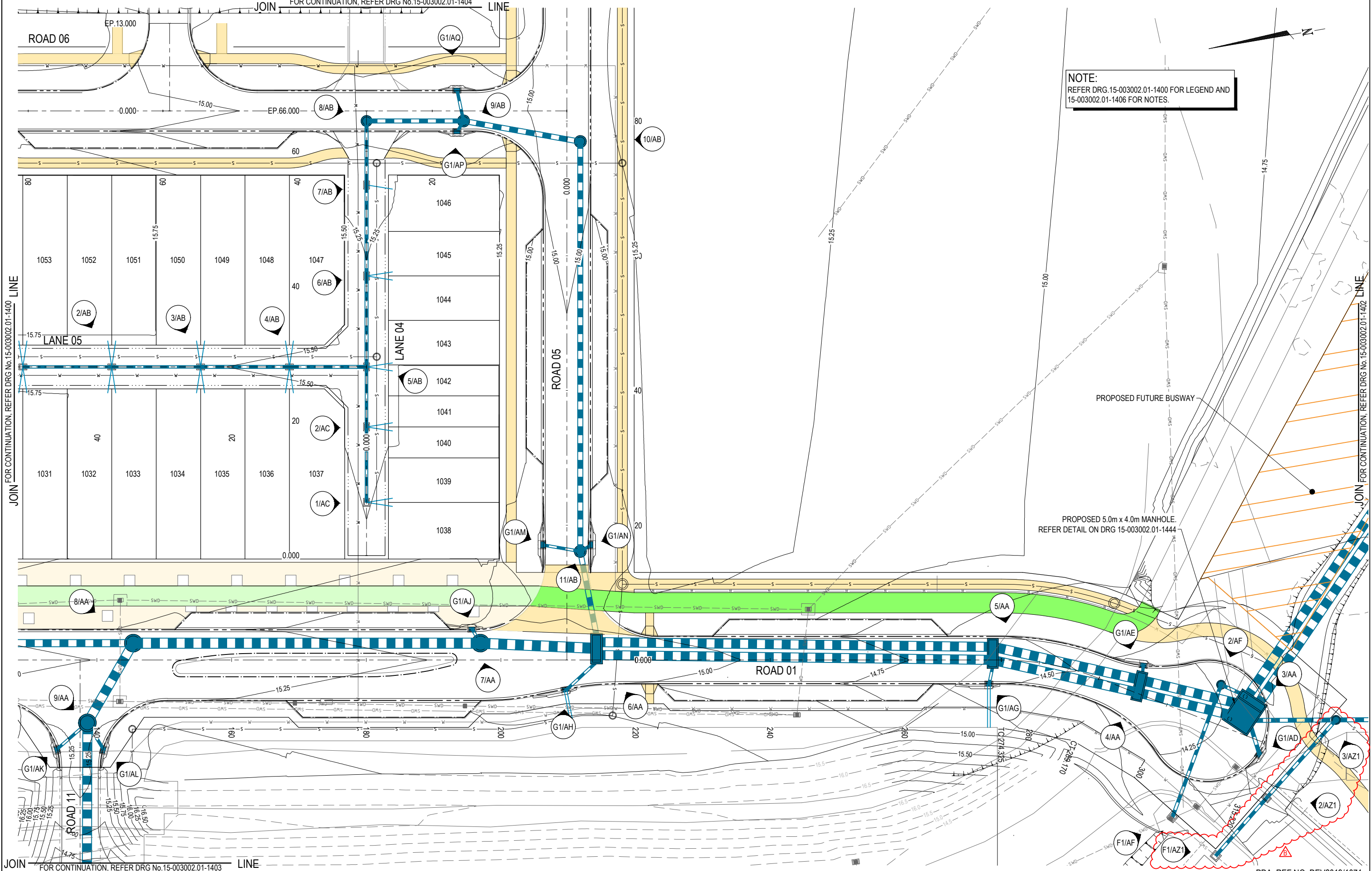

**NOTE:**  
REFER DRG.15-003002.01-1400 FOR LEGEND AND  
15-003002.01-1406 FOR NOTES.

FOR CONTINUATION, REFER DRG No.15-003002.01-1403

| REVISION | DATE     | ISSUE DETAILS                       | DRAWN | DESIGN | DRAWN CHECK | STATUS |
|----------|----------|-------------------------------------|-------|--------|-------------|--------|
| 1        | 1.11.19  | ISSUED FOR APPROVAL                 | CHC   | AA     |             |        |
| 2        | 16.04.20 | STORMWATER DRAINAGE NETWORK AMENDED | CHC   | AA     | aa          |        |
| A        | 28.10.20 | CARPARKING ON ROAD 1 AND 5 REVISED  | CHC   | AA     |             |        |
| B        | 23.03.21 | LINE AZ1 ADDED                      | AR    | AA     |             |        |

**FOR CONSTRUCTION**

APPROVED  
**LESLIE ROCHE** RPEQ 14843

FOR & ON BEHALF OF CALIBRE PROFESSIONAL SERVICES PTY LTD

SCALE  
1:250  
1:500

CLIENT  
**ECONOMIC DEVELOPMENT  
QUEENSLAND**

© calibregroup.com

PROJECT  
**CARSELDINE URBAN VILLAGE  
STAGE 1**

DISCLAIMER  
ALL DIMENSIONS TO BE CHECKED ON SITE BY CONTRACTOR PRIOR TO CONSTRUCTION. USE WRITTEN DIMENSIONS ONLY. DO NOT SCALE.

DRAWING TITLE  
**STORMWATER DRAINAGE  
LAYOUT PLAN  
SHEET 2 OF 6**

PROJECT No. 15-003002.01  
DRAWING No. 1401  
REVISION B

PDA. REF NO. DEV2019/1074



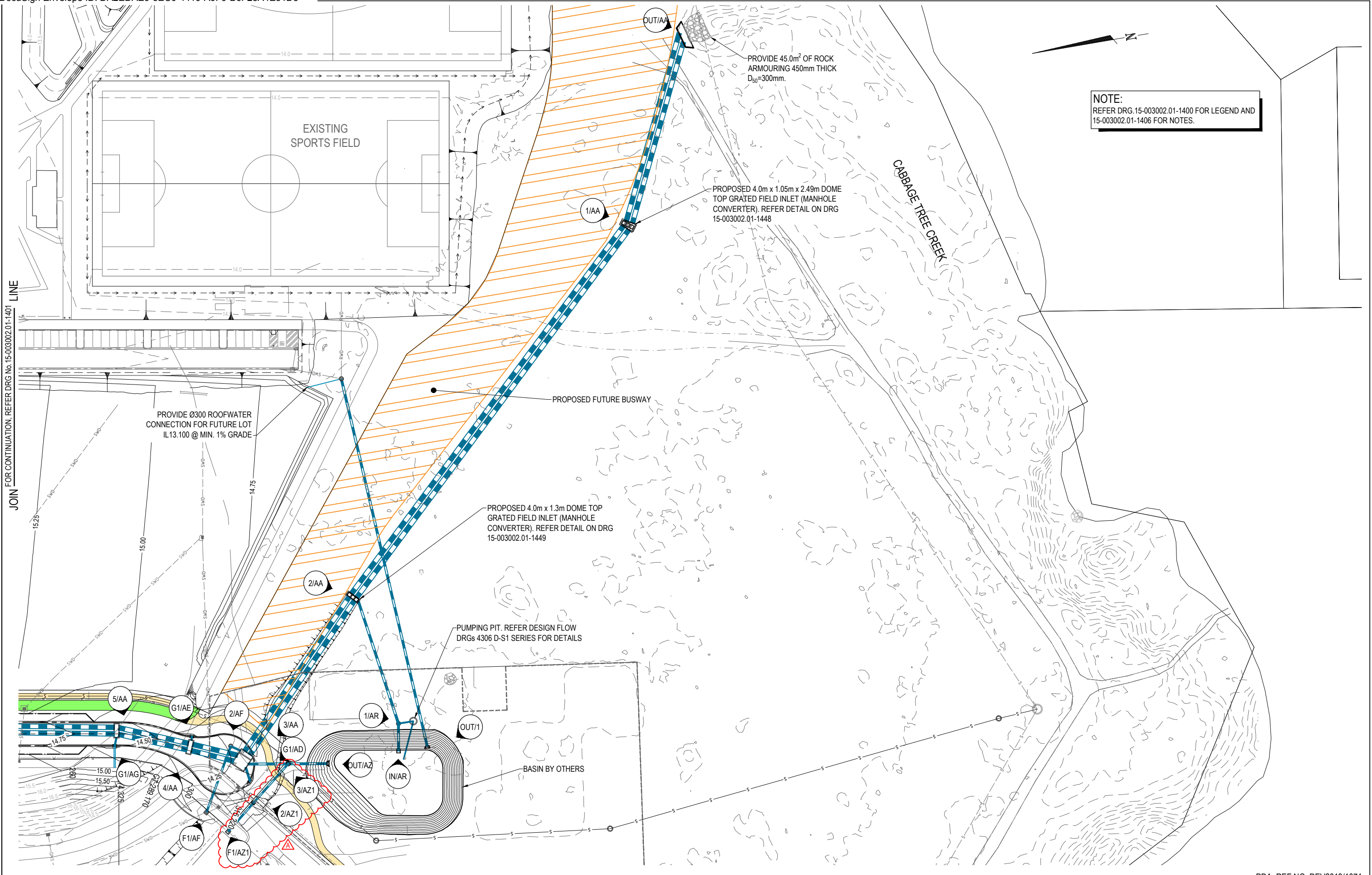

**NOTE:**  
REFER DRG.15-003002.01-1400 FOR LEGEND AND  
15-003002.01-1406 FOR NOTES.

JOIN FOR CONTINUATION, REFER DRG No. 15-003002.01-1401 LINE

| REVISION | DATE     | ISSUE DETAILS                       |
|----------|----------|-------------------------------------|
| 1        | 1.11.19  | ISSUED FOR APPROVAL                 |
| 2        | 16.04.20 | STORMWATER DRAINAGE NETWORK AMENDED |
| 3        | 15.05.20 | SEWER ALIGNMENT REVISED             |
| 4        | 29.05.20 | OUT/1 LOCATION REVISED              |
| A        | 23.03.21 | LINE AZ1 ADDED                      |

| DRAWN | DESIGN | DRAWN CHECK | STATUS           |
|-------|--------|-------------|------------------|
| CHC   | AA     | aa          | FOR CONSTRUCTION |
| CHC   | AA     | aa          |                  |
| AA    | AA     | aa          |                  |
| AA    | AA     | aa          |                  |
| AR    | AA     | aa          |                  |

APPROVED  
**LESLIE ROCHE**  
RPEQ 14843  
FOR & ON BEHALF OF CALIBRE PROFESSIONAL SERVICES PTY LTD

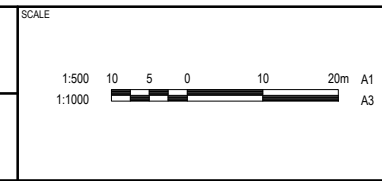

CLIENT  
**ECONOMIC DEVELOPMENT  
QUEENSLAND**



PROJECT  
**CARSELDINE URBAN VILLAGE  
STAGE 1**

| DRAWING TITLE   |             |          |
|---|-------------|----------|
| <b>STORMWATER DRAINAGE<br/>LAYOUT PLAN<br/>SHEET 3 OF 6</b> |             |          |
| PROJECT No.   | DRAWING No. | REVISION |
| 15-003002.01  | 1402        | A        |

DISCLAIMER  
ALL DIMENSIONS TO BE CHECKED ON SITE BY CONTRACTOR PRIOR TO  
CONSTRUCTION. USE WRITTEN DIMENSIONS ONLY. DO NOT SCALE.

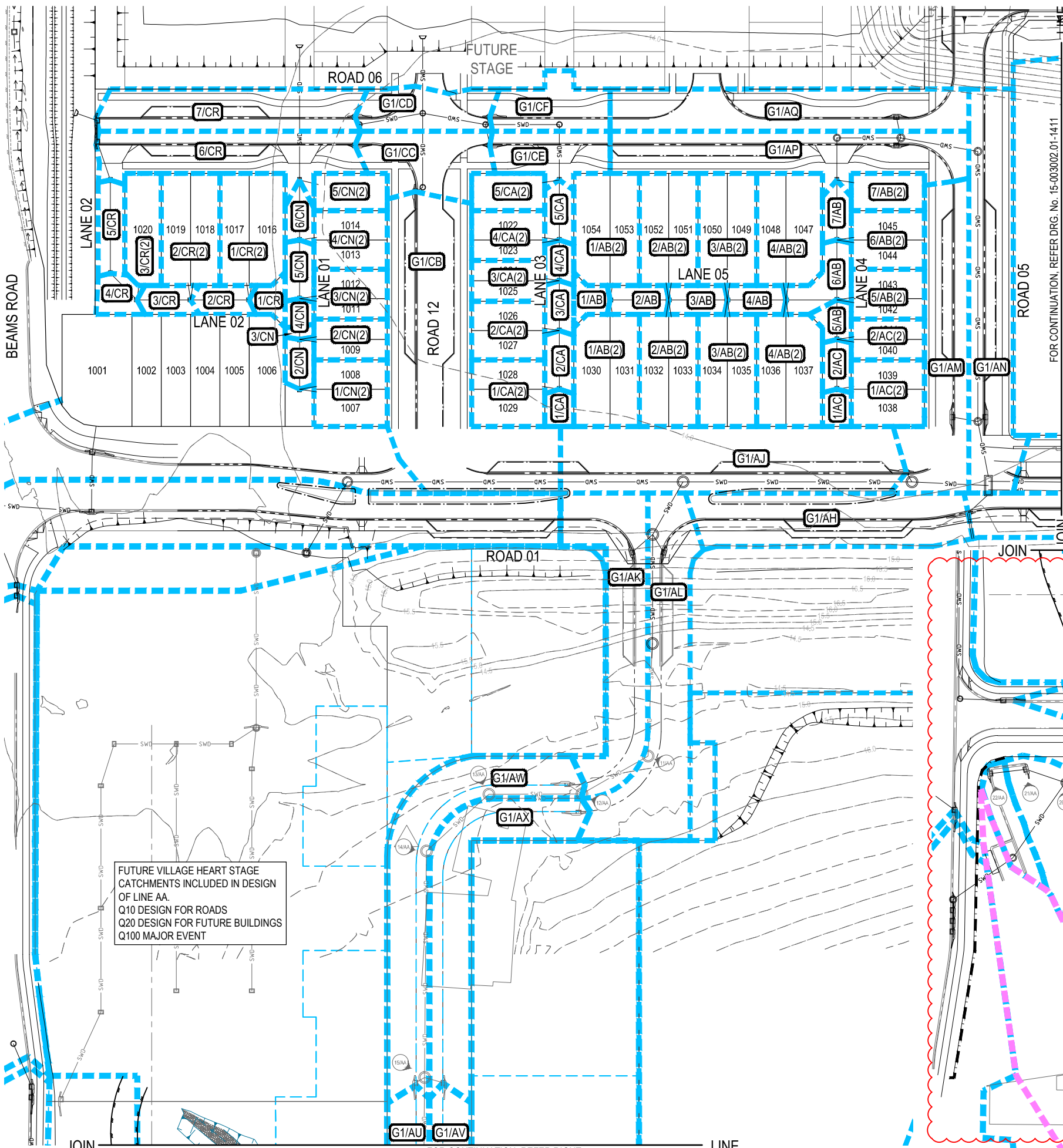

**CATCHMENT TABLE**

| CATCHMENT No. | CATCHMENT AREA (Ha.) | CATCHMENT No. | CATCHMENT AREA (Ha.) |
|---------------|----------------------|---------------|----------------------|
| 1/CR          | 0.0056               | 1/CA(2)       | 0.0247               |
| 2/CR          | 0.0085               | 2/CA(2)       | 0.0218               |
| 3/CR          | 0.0079               | 3/CA(2)       | 0.0152               |
| 4/CR          | 0.0084               | 4/CA(2)       | 0.0185               |
| 5/CR          | 0.0125               | 5/CA(2)       | 0.0139               |
| 6/CR          | 0.0602               | 1/CA          | 0.0051               |
| 7/CR          | 0.0554               | 2/CA          | 0.0086               |
| 1/CR(2)       | 0.0367               | 3/CA          | 0.0073               |
| 2/CR(2)       | 0.0333               | 4/CA          | 0.0060               |
| 3/CR(2)       | 0.0203               | 5/CA          | 0.0084               |
|               |                      | 1/AB(2)       | 0.0739               |
| 2/CN          | 0.0072               | 2/AB(2)       | 0.0667               |
| 3/CN          | 0.0060               | 3/AB(2)       | 0.0667               |
| 4/CN          | 0.0085               | 4/AB(2)       | 0.0738               |
| 5/CN          | 0.0071               | 1/AB          | 0.0060               |
| 1/CN(2)       | 0.0247               | 2/AB          | 0.0086               |
| 2/CN(2)       | 0.0152               | 3/AB          | 0.0086               |
| 3/CN(2)       | 0.0185               | 4/AB          | 0.0086               |
| 4/CN(2)       | 0.0218               | 1/AC          | 0.0052               |
| 5/CN(2)       | 0.0139               | 2/AC          | 0.0073               |
| G1/AK         | 0.0614               | 5/AC          | 0.0063               |
| G1/AL         | 0.0604               | 6/AC          | 0.0147               |
| G1/AJ         | 0.1147               | 7/AC          | 0.0078               |
| G1/AH         | 0.0740               | 1/AC(2)       | 0.0248               |
| G1/AG         | 0.0616               | 2/AC(2)       | 0.0152               |
| G1/AD         | 0.1031               | 5/AB(2)       | 0.0185               |
| G1/AE         | 0.0934               | 6/AB(2)       | 0.0218               |
| G1/AN         | 0.0932               | 7/AB(2)       | 0.0139               |
| G1/AM         | 0.0786               | G1/AU         | 0.0506               |
| G1/AP         | 0.0809               | G1/AV         | 0.0730               |
| G1/AQ         | 0.0768               | G1/AW         | 0.0973               |
| G1/CB         | 0.1513               | G1/AX         | 0.0846               |
| G1/CC         | 0.0382               | F1/AZ1        | 1.4241               |
| G1/CD         | 0.0283               | F1/AF         | 1.3923               |
| G1/CE         | 0.0270               | EX1           | 1.1700               |
| G1/CF         | 0.0276               |               |                      |

**LEGEND**

- G3/72 STORMWATER CATCHMENT NAME
- G5a/72 FUTURE CATCHMENT NAME
- STORMWATER CATCHMENT BOUNDARY
- 64.0 EXISTING SURFACE CONTOUR (0.5m INTERVALS)
- 66.0 DESIGN SURFACE CONTOUR (0.5m INTERVALS)
- SWD PROPOSED STORMWATER DRAINAGE
- SWD STORMWATER DRAINAGE BY OTHERS
- SWD FUTURE STORMWATER DRAINAGE
- SWD EXISTING STORMWATER DRAINAGE

**CAUTION !! UNDERGROUND TELECOMMS CABLES**  
 UNDERGROUND TELECOMMUNICATION CABLES EXIST IN THIS VICINITY. CONTACT SUPPLIER FOR CABLE LOCATIONS. EXTREME CARE MUST BE TAKEN WHILST EXCAVATING.

**CAUTION !! UNDERGROUND GAS MAIN**  
 UNDERGROUND GAS MAIN EXIST IN THIS VICINITY. CONTACT SUPPLIER FOR MAIN LOCATIONS. EXTREME CARE MUST BE TAKEN WHILST EXCAVATING.

**CAUTION !! UNDERGROUND ELECTRICAL CABLES**  
 UNDERGROUND ELECTRICITY CABLES EXIST IN THIS VICINITY. CONTACT ENERGEX FOR CABLE LOCATIONS. EXTREME CARE MUST BE TAKEN WHILST EXCAVATING.

**CAUTION !! OVERHEAD ELECTRICAL CABLES**  
 OVERHEAD ELECTRICITY CABLES EXIST IN THIS VICINITY. CONTACT ENERGEX WHERE CABLE CLEARANCE IS COMPROMISED BY MACHINERY.

FUTURE VILLAGE HEART STAGE CATCHMENTS INCLUDED IN DESIGN OF LINE AA.  
 Q10 DESIGN FOR ROADS  
 Q20 DESIGN FOR FUTURE BUILDINGS  
 Q100 MAJOR EVENT

EXTERNAL CATCHMENT 'EX1' INCLUDED IN DESIGN OF LINE AA. Q100 MAJOR EVENT

| REVISION | DATE     | ISSUE DETAILS             | DRAWN | DESIGN |
|----------|----------|---------------------------|-------|--------|
| 1        | 1.11.19  | ISSUED FOR APPROVAL       | CHC   | AA     |
| 2        | 16.04.20 | CATCHMENT AREAS AMENDED   | CHC   | AA     |
| 3        | 15.05.20 | MINOR DRAINAGE AMENDMENTS | AA    | AA     |
| 4        | 07.07.20 | 1/CN CATCHMENT REMOVED    | CHC   | AA     |
| A        | 23.03.21 | LINE AZ1 ADDED            | AR    | AA     |

FOR CONTINUATION, REFER RIGHT

**FOR CONSTRUCTION**

APPROVED: LESLIE ROCHE RPEQ 14843

FOR & ON BEHALF OF: [Signature]

SCALE

1:500 10 5 0 10 20m A1  
 1:1000

CLIENT

**ECONOMIC DEVELOPMENT QUEENSLAND**

calibre group.com

PROJECT

**CARSELDINE URBAN VILLAGE STAGE 1**

DISCLAIMER: ALL DIMENSIONS TO BE CHECKED ON SITE BY CONTRACTOR PRIOR TO CONSTRUCTION. USE WRITTEN DIMENSIONS ONLY. DO NOT SCALE.

DRAWING TITLE

**STORMWATER DRAINAGE CATCHMENT PLAN SHEET 1 OF 2**

DRAWING No. 15-003002.01  
 REVISION 1410  
 A

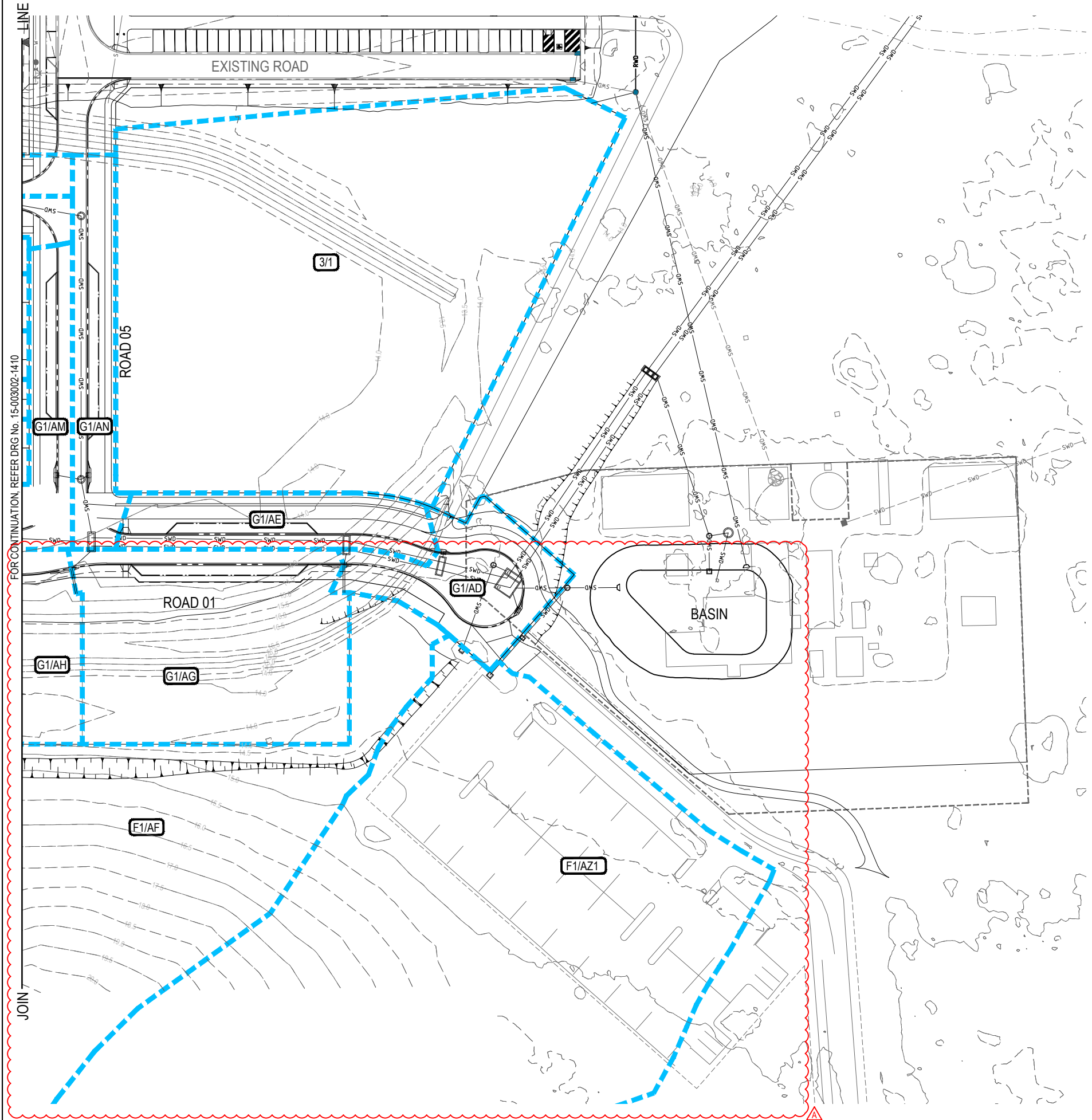

**NOTE:**  
REFER DRG.15-003002.01-1410 FOR LEGEND AND NOTES.

FOR CONTINUATION, REFER DRG No. 15-003002-1410

JOIN

| REVISION | DATE     | ISSUE DETAILS             | DRAWN | DESIGN | DRAWN CHECK | STATUS           |
|----------|----------|---------------------------|-------|--------|-------------|------------------|
| 1        | 1.11.19  | ISSUED FOR APPROVAL       | CHC   | AA     |             | FOR CONSTRUCTION |
| 2        | 16.04.20 | CATCHMENT AREAS AMENDED   | CHC   | AA     | aa          |                  |
| 3        | 15.05.20 | MINOR DRAINAGE AMENDMENTS | AA    | AA     |             |                  |
| A        | 23.03.21 | LINE AZ1 ADDED            | AR    | AA     |             |                  |

| DRAWN CHECK  | DESIGN CHECK | APPROVED     | PROJECT NO. |
|--|--------------|--------------|-------------|
| aa   | aa           | LESLIE ROCHE | RPEQ 14843  |
| FOR & ON BEHALF OF CALIBRE PROFESSIONAL SERVICES PTY LTD |              |              |             |

SCALE

1:500 10 5 0 10 20m A1  
1:1000

CLIENT

**ECONOMIC DEVELOPMENT  
QUEENSLAND**



PROJECT

**CARSELDINE URBAN VILLAGE  
STAGE 1**

DISCLAIMER  
ALL DIMENSIONS TO BE CHECKED ON SITE BY CONTRACTOR PRIOR TO CONSTRUCTION. USE WRITTEN DIMENSIONS ONLY. DO NOT SCALE.

| DRAWING TITLE  | PROJECT No.  | DRAWING No. | REVISION |
|--|--------------|-------------|----------|
| <b>STORMWATER DRAINAGE<br/>CATCHMENT PLAN<br/>SHEET 2 OF 2</b> | 15-003002.01 | 1411        | A        |

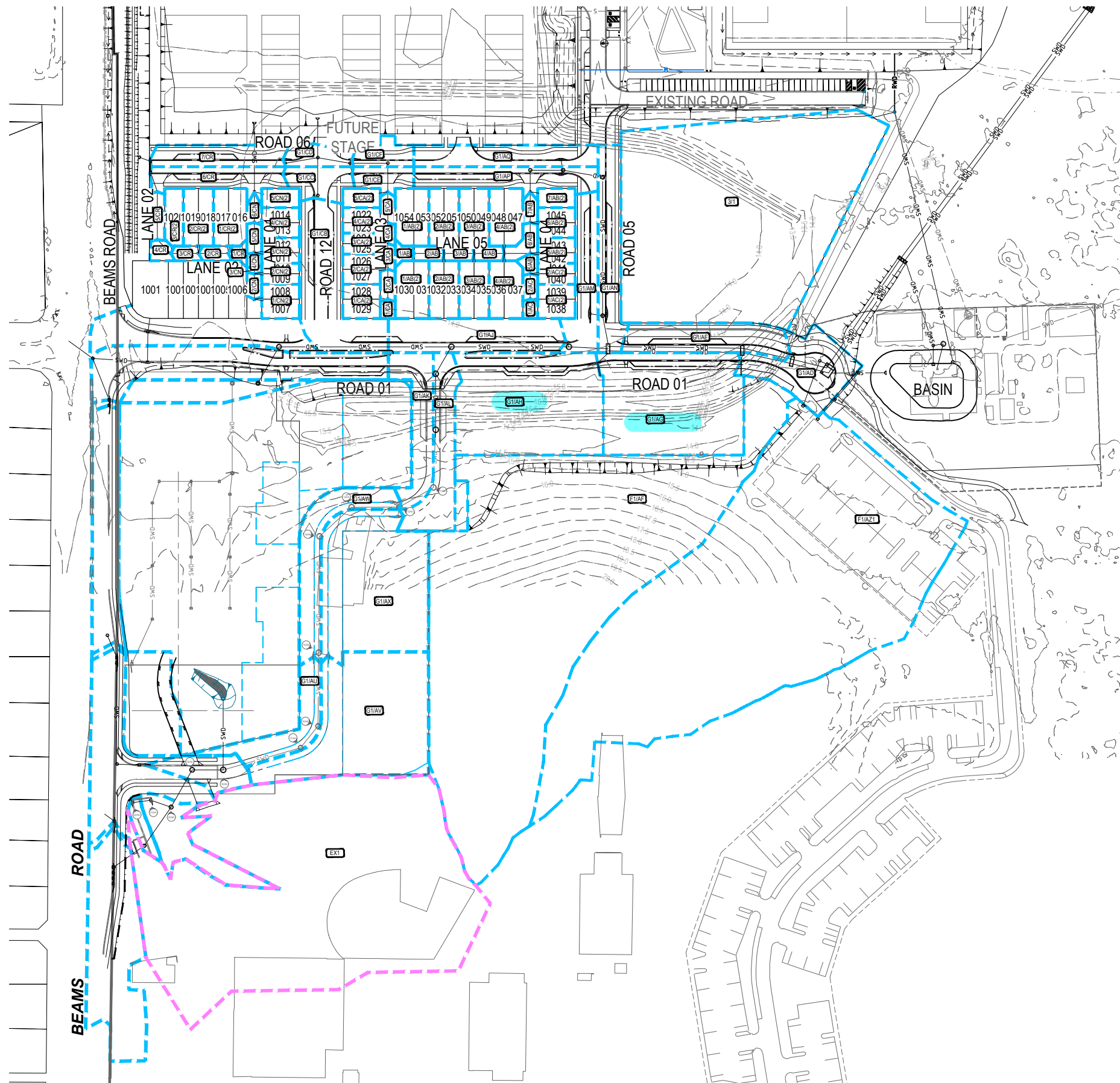

NOTE:  
REFER DRG.15-003002.01-1410 FOR LEGEND AND NOTES.

| REVISION | DATE     | ISSUE DETAILS  |
|----------|----------|----------------|
| A        | 23.03.21 | LINE A21 ADDED |

| DRAWN | DESIGN |
|-------|--------|
| AR    | AA     |

| DRAWN CHECK  | STATUS   |
|--------------|--|
| aa           | FOR CONSTRUCTION   |
| DESIGN CHECK | APPROVED<br>LESLIE ROCHE RPEQ 14843                      |
| aa           | FOR & ON BEHALF OF CALIBRE PROFESSIONAL SERVICES PTY LTD |

| SCALE                                    |
|--|
| 1:1000 10 0 10 20 30 40 50m A1<br>1:2000 |

| CLIENT                          |
|---------------------------------|
| ECONOMIC DEVELOPMENT QUEENSLAND |



| PROJECT  |
|--|
| CARSELDINE URBAN VILLAGE STAGE 1   |
| DISCLAIMER<br>ALL DIMENSIONS TO BE CHECKED ON SITE BY CONTRACTOR PRIOR TO CONSTRUCTION. USE WRITTEN DIMENSIONS ONLY. DO NOT SCALE. |

| DRAWING TITLE                               |             |          |
|---|-------------|----------|
| STORMWATER DRAINAGE EXTERNAL CATCHMENT PLAN |             |          |
| PROJECT No.                                 | DRAWING No. | REVISION |
| 15-003002.01                                | 1412        | A        |

PDA. REF NO. DEV2019/1074

| STRUCTURE NAME        | <b>G1/AG</b>  |
|-----------------------|---|
| STRUCTURE DESCRIPTION | GULLY PIT<br>L.L.L: 3.6m Limef. B&C                             |
|                       | 4.0m x 1.2m MANHOLE<br>REFER DRG: 1443 FOR<br>STRUCTURE DETAILS |

**LEGEND**

- DESIGN SURFACE
- - - EXISTING SURFACE
- - - Q2 HYDRAULIC GRADE LINE

**NOTES:**

- NOTWITHSTANDING THE STORMWATER STRUCTURE LEVELS SHOWN, THE COVER OR GRATE LEVEL SHALL SUIT THE FINISHED SURFACE PROFILE.
- THE PIPE CLASSES HAVE BEEN DESIGNED FOR SERVICE LOADS ONLY. THE CONTRACTOR SHALL ASSESS ANTICIPATED LOADS AND UPGRADE THE PIPE CLASSES IF NECESSARY IN ACCORDANCE WITH AS 3725-1989. CRACKED PIPES WILL NOT BE ACCEPTED.

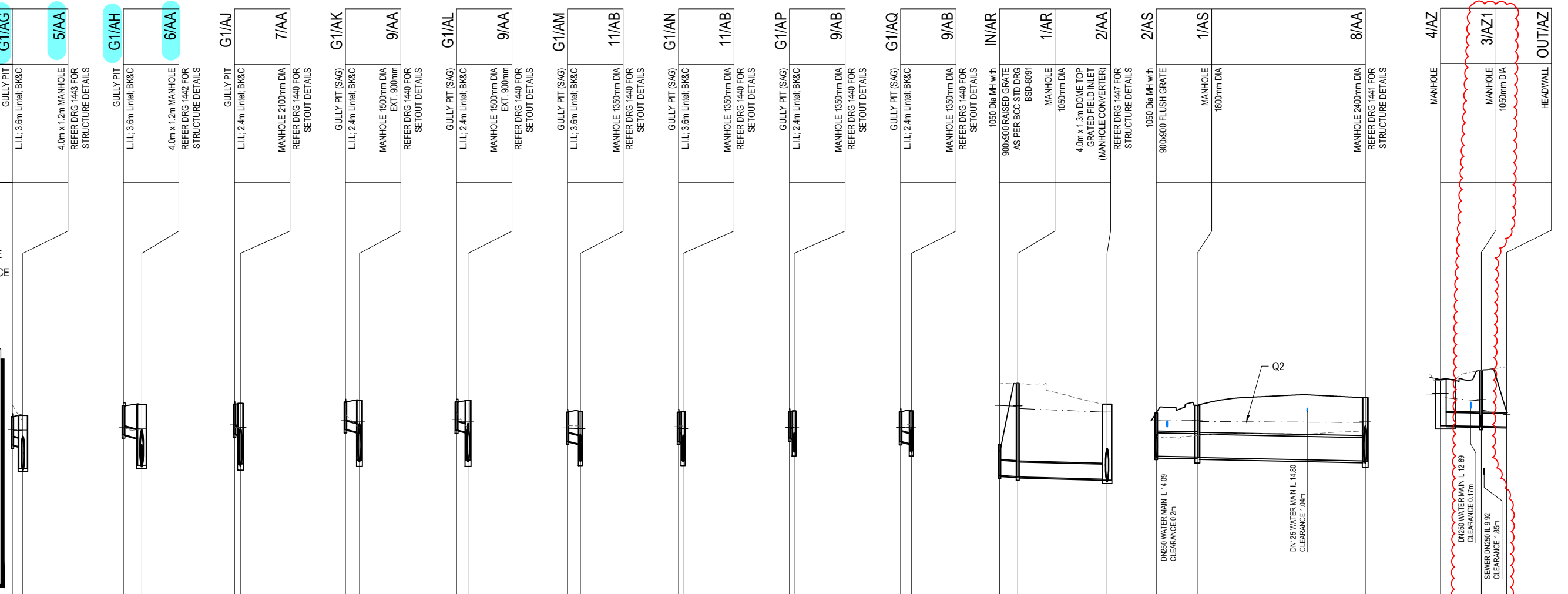

| PIPE SIZE (mm) | PIPE CLASS | PIPE GRADE (%) | PIPE SLOPE (1 in X) | FULL PIPE VELOCITY (m/s) | PART FULL VELOCITY (m/s) | DATUM RL    | H.G.L IN PIPE & W.S.E IN STRUCTURE             | PIPE FLOW (Cumecs) | PIPE CAPACITY AT GRADE (Cumecs) | DEPTH TO INVERT | INVERT LEVEL OF DRAIN | DESIGN SURFACE LEVEL | SETOUT COORDINATES            | RUNNING CHAINAGE |
|----------------|------------|----------------|---------------------|--------------------------|--------------------------|-------------|--|--------------------|---------------------------------|-----------------|-----------------------|----------------------|-------------------------------|------------------|
| <b>375</b>     | 3          | 1.39%          | 71.94               | 0.29                     | 1.36                     | <b>0.0</b>  | 13.964<br>13.932<br>13.930<br>13.939<br>13.982 | 0.032              | 0.207                           | 1.290           | 13.261                | 14.551               | E 502611.833<br>N 6974702.417 | 0.000<br>4.736   |
| <b>375</b>     | 3          | 2.03%          | 49.22               | 0.35                     | 1.64                     | <b>0.0</b>  | 14.055<br>13.994<br>13.995<br>14.001<br>13.966 | 0.039              | 0.250                           | 1.315           | 13.731                | 15.046               | E 502621.616<br>N 6974764.528 | 0.000<br>8.261   |
| 375            | 3          | 1.88%          | 53.09               | 0.50                     | 1.77                     | <b>0.0</b>  | 14.177<br>14.051<br>14.054<br>14.059<br>14.014 | 0.056              | 0.241                           | 1.343           | 13.768                | 15.111               | E 502633.064<br>N 6974776.707 | 0.000<br>2.699   |
| 375            | 3          | 1.94%          | 51.44               | 0.38                     | 1.65                     | <b>0.0</b>  | 14.388<br>14.317<br>14.314<br>14.314<br>14.314 | 0.042              | 0.245                           | 1.239           | 13.967                | 15.206               | E 502624.676<br>N 6974840.617 | 0.000<br>6.316   |
| 375            | 3          | 1.83%          | 54.64               | 0.44                     | 1.69                     | <b>0.0</b>  | 14.416<br>14.318<br>14.314<br>14.314<br>14.314 | 0.049              | 0.237                           | 1.268           | 13.939                | 15.207               | E 502643.531<br>N 6974833.597 | 0.000<br>5.183   |
| 375            | 3          | 2.00%          | 49.93               | 0.39                     | 1.69                     | <b>0.0</b>  | 14.081<br>14.015<br>14.011<br>14.011<br>14.004 | 0.043              | 0.248                           | 1.317           | 13.431                | 14.748               | E 502644.352<br>N 6974764.352 | 0.000<br>5.792   |
| 375            | 3          | 3.23%          | 30.97               | 0.44                     | 2.07                     | <b>0.0</b>  | 14.094<br>14.013<br>14.011<br>14.011<br>14.004 | 0.048              | 0.315                           | 1.317           | 13.431                | 14.748               | E 502642.283<br>N 6974757.055 | 0.000<br>2.044   |
| 450            | 3          | 1.92%          | 52.01               | 0.16                     | 1.38                     | <b>0.0</b>  | 14.062<br>14.051<br>14.050<br>14.050<br>14.048 | 0.025              | 0.395                           | 1.188           | 13.586                | 14.774               | E 502705.980<br>N 6974766.480 | 0.000<br>2.044   |
| 450            | 3          | 1.99%          | 50.13               | 0.15                     | 1.38                     | <b>0.0</b>  | 14.061<br>14.051<br>14.050<br>14.050<br>14.048 | 0.023              | 0.403                           | 1.349           | 13.425                | 14.774               | E 502712.292<br>N 6974765.400 | 0.000<br>4.813   |
| 675            | 3          | 0.61%          | 163.84              | 1.52                     | 2.05                     | <b>-1.0</b> | 14.047<br>14.047<br>14.012<br>14.032<br>13.914 | 0.543              | 0.657                           | 1.400           | 10.900                | 12.300               | E 502586.226<br>N 6974619.525 | 0.000<br>8.192   |
| 675            | 3          | 0.25%          | 402.61              | 1.52                     | 1.88                     |             | 14.047<br>14.047<br>14.012<br>14.032<br>13.914 | 0.543              | 0.593                           | 4.189           | 10.850                | 15.039               | E 502604.303<br>N 6974618.160 | 8.192<br>40.261  |
| 1050           | 4          | 0.20%          | 500.00              | 0.73                     | 1.42                     | <b>0.0</b>  | 14.399<br>14.399<br>14.389<br>14.398<br>14.327 | 0.636              | 1.222                           | 1.939           | 12.764                | 14.703               | E 502637.901<br>N 6974912.950 | 0.000<br>18.474  |
| 1050           | 4          | 0.20%          | 500.00              | 0.73                     | 1.42                     |             | 14.399<br>14.399<br>14.389<br>14.398<br>14.327 | 0.636              | 1.222                           | 2.327           | 12.727                | 15.054               | E 502652.114<br>N 6974901.148 | 18.474<br>75.671 |
| 600            | 3          | 0.17%          | 597.34              | 1.89                     | 2.72                     | <b>-2.0</b> | 13.547<br>13.357<br>13.218<br>13.273<br>12.801 | 0.534              | 0.251                           | 2.062           | 12.116                | 14.178               | E 502601.402<br>N 6974665.653 | -0.000<br>18.388 |
| 600            | 3          | 0.22%          | 455.29              | 1.89                     | 2.72                     |             | 13.547<br>13.357<br>13.218<br>13.273<br>12.801 | 0.770              | 0.288                           | 2.082           | 12.096                | 14.593               | E 502598.023<br>N 6974652.479 | 18.388<br>11.481 |

| REVISION | DATE     | ISSUE DETAILS                            | DRAWN | DESIGN | DRAWN CHECK | STATUS           |
|----------|----------|--|-------|--------|-------------|------------------|
| 1        | 1.11.19  | ISSUED FOR APPROVAL                      | CHC   | AA     |             | FOR CONSTRUCTION |
| 2        | 16.04.20 | STORMWATER LONGITUDINAL SECTIONS AMENDED | CHC   | AA     | aa          |                  |
| 3        | 20.05.20 | LINE AR AND MANHOLE 2/AS REVISED         | CHC   | AA     |             |                  |
| 4        | 07.07.20 | LINE AR AMENDED                          | CHC   | AA     |             |                  |
| A        | 23.03.21 | LINE AZ1 ADDED                           | AR    | AA     | aa          | APPROVED         |

FOR & ON BEHALF OF **calibre** PROFESSIONAL SERVICES PTY LTD

APPROVED  
LESLIE ROCHE RPEQ 14843

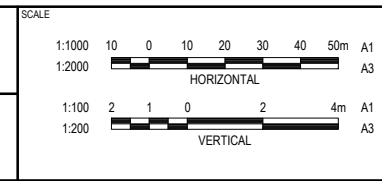

CLIENT

**ECONOMIC DEVELOPMENT QUEENSLAND**



PROJECT

**CARSELDINE URBAN VILLAGE STAGE 1**

DISCLAIMER  
ALL DIMENSIONS TO BE CHECKED ON SITE BY CONTRACTOR PRIOR TO CONSTRUCTION. USE WRITTEN DIMENSIONS ONLY. DO NOT SCALE.

| DRAWING TITLE  |  | DRAWING No.  | REVISION |
|--|--|--------------|----------|
| STORMWATER DRAINAGE LONGITUDINAL SECTIONS SHEET 3 OF 6 |  | 1422         | A        |
| PROJECT No.  |  | 15-003002.01 |          |
| DRAWING No.  |  | 1422         |          |
| REVISION   |  | A            |          |

PDA REF NO. DEV2019/1074

| STRUCTURE NAME        | F1/AZ1                              | 2/AZ1                              | 3/AZ1                 |
|-----------------------|-------------------------------------|------------------------------------|-----------------------|
| STRUCTURE DESCRIPTION | FIELD INLET<br>900x900 RAISED GRATE | FIELD INLET<br>600x900 FLUSH GRATE | MANHOLE<br>1050mm DIA |

**LEGEND**

- DESIGN SURFACE
- - - EXISTING SURFACE
- - - Q2 HYDRAULIC GRADE LINE

**NOTES:**

- NOTWITHSTANDING THE STORMWATER STRUCTURE LEVELS SHOWN, THE COVER OR GRATE LEVEL SHALL SUIT THE FINISHED SURFACE PROFILE.
- THE PIPE CLASSES HAVE BEEN DESIGNED FOR SERVICE LOADS ONLY. THE CONTRACTOR SHALL ASSESS ANTICIPATED LOADS AND UPGRADE THE PIPE CLASSES IF NECESSARY IN ACCORDANCE WITH AS 3725-1989. CRACKED PIPES WILL NOT BE ACCEPTED.

| PIPE SIZE (mm)                     | 450                           | 450  |
|------------------------------------|-------------------------------|--|
| PIPE CLASS                         | 3                             | 3  |
| PIPE GRADE (%)                     | 0.54%                         | 0.55%  |
| PIPE SLOPE (1 in X)                | 184.61                        | 182.33   |
| FULL PIPE VELOCITY (m/s)           | 1.49                          | 1.49   |
| PART FULL VELOCITY (m/s)           | 1.49                          | 1.49   |
| DATUM RL                           | -1.0                          |  |
| H.G.L IN PIPE & W.S.E IN STRUCTURE | 13.757<br>13.428              | 13.349<br>13.349<br>13.324<br>13.218<br>13.273<br>12.901       |
| PIPE FLOW (Cumecs)                 | 0.237                         | 0.236  |
| PIPE CAPACITY AT GRADE (Cumecs)    | 0.210                         | 0.211  |
| DEPTH TO INVERT                    | 1.792                         | 2.508<br>2.528   |
| INVERT LEVEL OF DRAIN              | 12.252                        | 12.085<br>12.065   |
| DESIGN SURFACE LEVEL               | 14.044                        | 14.593   |
| SETOUT COORDINATES                 | E 502581.142<br>N 6974873.479 | E 502588.348<br>N 6974864.597<br>E 502598.023<br>N 6974852.479 |
| RUNNING CHAINAGE                   | 0.000<br>11.446               | 15.498<br>26.944   |

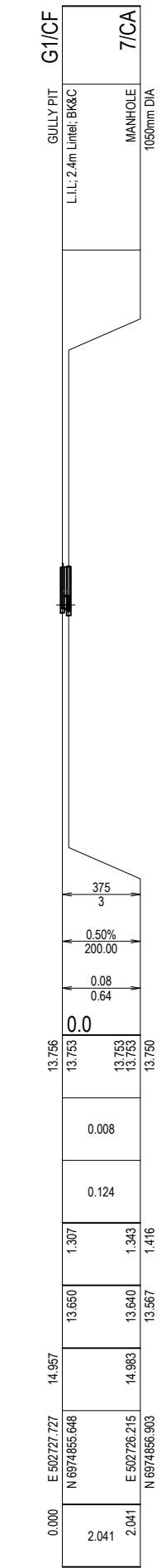
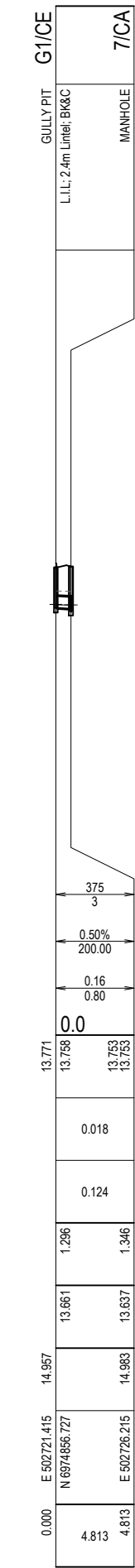
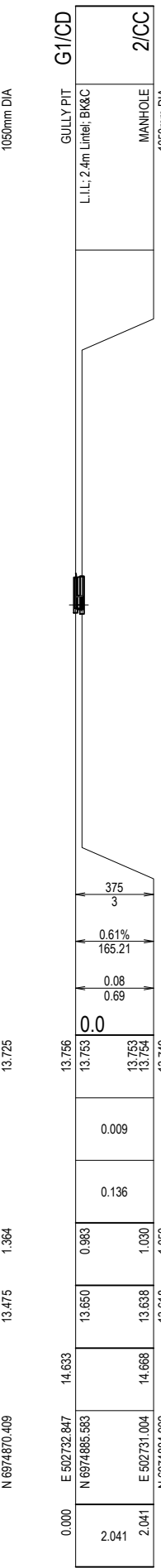
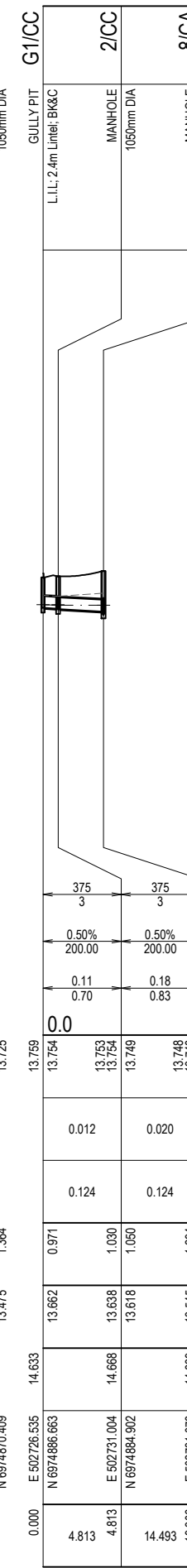
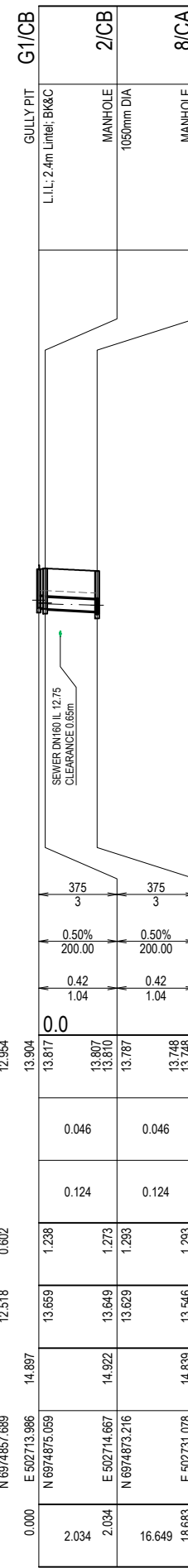
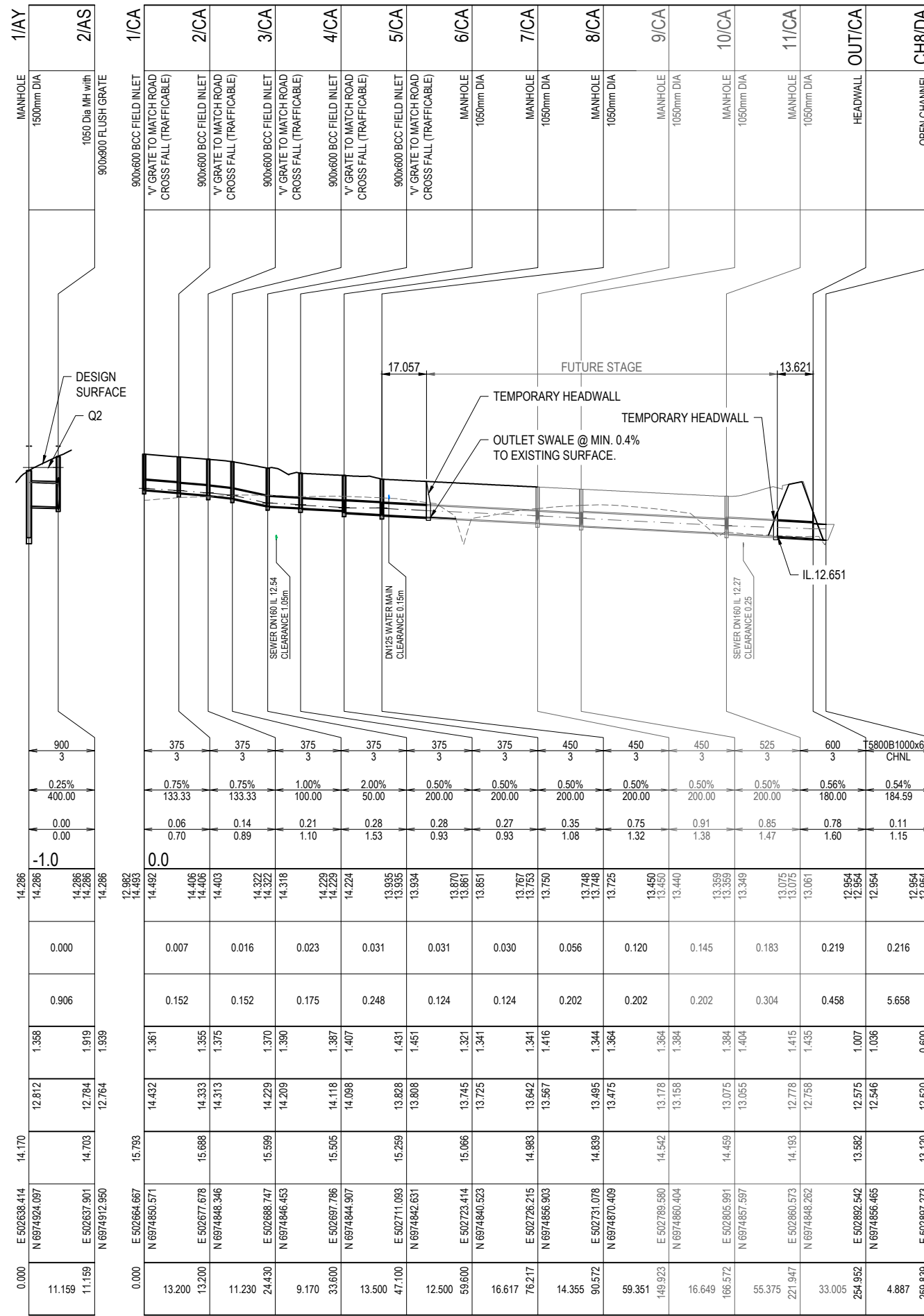

| REVISION | DATE     | ISSUE DETAILS                            | DRAWN | DESIGN | DRAWN CHECK | STATUS |
|----------|----------|--|-------|--------|-------------|--------|
| 1        | 1.11.19  | ISSUED FOR APPROVAL                      | CHC   | AA     |             |        |
| 2        | 16.04.20 | STORMWATER LONGITUDINAL SECTIONS AMENDED | CHC   | AA     | aa          |        |
| 3        | 15.05.20 | STORMWATER NETWORK AMENDED               | AA    | AA     |             |        |
| 4        | 20.05.20 | LINE CA AND AY REVISED                   | CHC   | AA     |             |        |
| A        | 23.03.21 | LINE AZ1 ADDED                           | AR    | AA     | aa          |        |

**FOR CONSTRUCTION**

APPROVED  
LESLIE ROCHE  
RPEQ 14843

FOR & ON BEHALF OF CALIBRE PROFESSIONAL SERVICES PTY LTD

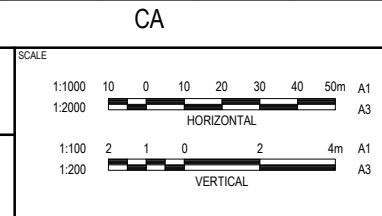

CLIENT  
**ECONOMIC DEVELOPMENT QUEENSLAND**



PROJECT  
**CARSELDINE URBAN VILLAGE STAGE 1**

DISCLAIMER  
ALL DIMENSIONS TO BE CHECKED ON SITE BY CONTRACTOR PRIOR TO CONSTRUCTION. USE WRITTEN DIMENSIONS ONLY. DO NOT SCALE.

| DRAWING TITLE   |             |          |
|---|-------------|----------|
| <b>STORMWATER DRAINAGE LONGITUDINAL SECTIONS SHEET 4 OF 6</b> |             |          |
| PROJECT No.   | DRAWING No. | REVISION |
| 15-003002.01  | 1423        | A        |

Main data table with columns: DESIGNARI, LOCATION, CATCHMENT PROPERTIES, FULL AREA RUNOFF, PART AREA RUNOFF, INLET DESIGN, DRAIN DESIGN, HEADLOSSES, PART FULL, DESIGN LEVELS. Rows include structure details like F1/1, G2/1, 3/1, etc.

Project summary and metadata including: REVISION table, ISSUE DETAILS, DRAWN/DESIGN/STATUS, CLIENT (ECONOMIC DEVELOPMENT QUEENSLAND), PROJECT (CARSELDINE URBAN VILLAGE STAGE 1), DRAWING TITLE (STORMWATER DRAINAGE MINOR CALCULATION TABLES SHEET 1 OF 6), and DRAWING No. (15-003002.01).



DISCLAIMER: ALL DIMENSIONS TO BE CHECKED ON SITE BY CONTRACTOR PRIOR TO CONSTRUCTION. USE WRITTEN DIMENSIONS ONLY. DO NOT SCALE.





| DESIGN ARI | LOCATION | CATCHMENT PROPERTIES |      |     | FULL AREA RUNOFF |     |       |       | PART AREA RUNOFF |    |     |       | INLET DESIGN |   |    |            |            |         |                     |                     | DRAIN DESIGN    |                 |             |                      |                        |                    |               |           |              |            | HEADLOSSES |                    |                   |                  |                |               |               |                           |               |                   | PART FULL       |                     | DESIGN LEVELS           |              |                   |             |             |              |              |        |             |           |
|------------|----------|----------------------|------|-----|------------------|-----|-------|-------|------------------|----|-----|-------|--------------|---|----|------------|------------|---------|---------------------|---------------------|-----------------|-----------------|-------------|----------------------|------------------------|--------------------|---------------|-----------|--------------|------------|------------|--------------------|-------------------|------------------|----------------|---------------|---------------|---------------------------|---------------|-------------------|-----------------|---------------------|-------------------------|--------------|-------------------|-------------|-------------|--------------|--------------|--------|-------------|-----------|
|            |          | fi                   | ci   | Cp  | tc               | I   | A     | CA    | Q                | tc | I   | A     | CA           | Q | Qa | Flow Width | Flow Depth | Flow Dv | Road Grade at Inlet | Road XFall at Inlet | Inlet Type      | Flow into Inlet | Bypass Flow | Bypass Structure No. | Critical Time of Conc. | Rainfall Intensity | Total (C x A) | Pipe Flow | Reach Length | Pipe Grade | Pipe Size  | Full Pipe Velocity | Submergence Ratio | Grate Flow Ratio | Diameter Ratio | Chart(s) Used | Velocity Head | U/S Head Loss Coefficient | U/S Head Loss | W.S.E Coefficient | Change in W.S.E | Pipe Friction Slope | Pipe Friction Head Loss | Normal Depth | Normal Depth Vel. | Pipe U/S IL | Pipe D/S IL | Pipe U/S G.L | Pipe D/S G.L | W.S.E  | Grate Level | Freeboard |
| 2          | 13/CN    | 98                   | 0.77 | 0.6 | 10               | 116 | 0.029 | 0.022 | 7                | 5  | 151 | 0.028 | 0.022        | 9 | 14 | 2.44       | 0.031      | 0.01    | 0.82                | 2.5                 | F1-6x9 on-grade | 10              | 4           | 12/CN                | 5.93                   | 142                | 0.259         | 86        | 11.2         | 0.38       | 450        | 0.54               | 1.02              | 0.12             | 1              | T1            | 0.015         | 0.74                      | 0.011         | 0.011             | 0.17            | 0.03                | 0.223                   | 1.1          | 12.888            | 12.846      | 13.124      | 13.104       | 13.14        | 14.528 | 1.393       | 13/CN     |

|   |  |  |  |                                 |  |                                |  |  |  |                             |  |  |  |   |  |  |  |   |  |                           |  |
|---|--|--|--|---------------------------------|--|--------------------------------|--|--|--|-----------------------------|--|--|--|---|--|--|--|---|--|---------------------------|--|
| <b>REVISION</b><br>1 1.11.19 ISSUED FOR APPROVAL<br>2 16.04.20 STORMWATER NETWORK AMENDED<br>3 15.05.20 STORMWATER NETWORK AMENDED<br>A 23.03.21 STORMWATER NETWORK AMENDED |  | <b>DRAWN</b><br>CHC AA<br>CHC AA<br>AA AA<br>AA AA |  | <b>DESIGN</b><br>AA AA<br>AA AA |  | <b>DRAWN CHECK</b><br>aa<br>aa |  | <b>STATUS</b><br>FOR CONSTRUCTION<br>APPROVED<br>LESLIE ROCHE RPEQ 14843<br>FOR & ON BEHALF OF CALIBRE PROFESSIONAL SERVICES PTY LTD |  | <b>SCALE</b><br>1:100       |  | <b>CLIENT</b><br>ECONOMIC DEVELOPMENT QUEENSLAND |  |  calibre<br>calibregroup.com |  | <b>PROJECT</b><br>CARSELDINE URBAN VILLAGE STAGE 1 |  | <b>DRAWING TITLE</b><br>STORMWATER DRAINAGE MINOR CALCULATION TABLES SHEET 3 OF 6 |  | PDA. REF NO. DEV2019/1074 |  |
| DISCLAIMER<br>ALL DIMENSIONS TO BE CHECKED ON SITE BY CONTRACTOR PRIOR TO CONSTRUCTION. USE WRITTEN DIMENSIONS ONLY. DO NOT SCALE.  |  |  |  |                                 |  |                                |  |  |  | PROJECT No.<br>15-003002.01 |  | DRAWING No.<br>1432                              |  | REVISION<br>A   |  |  |  |   |  |                           |  |

| DESIGNARI | LOCATION | CATCHMENT PROPERTIES |    |     | FULL AREA RUNOFF |     |       | PART AREA RUNOFF |     |   | INLET DESIGN |       |       |     |     |       |       | DRAIN DESIGN |     |     |   |    |      |       |        |       | HEADLOSSES |       |      |       |      |       |       |      | PART FULL |        | DESIGN LEVELS |        |      |        |       |       |  |  |  |  |  |
|-----------|----------|----------------------|----|-----|------------------|-----|-------|------------------|-----|---|--------------|-------|-------|-----|-----|-------|-------|--------------|-----|-----|---|----|------|-------|--------|-------|------------|-------|------|-------|------|-------|-------|------|-----------|--------|---------------|--------|------|--------|-------|-------|--|--|--|--|--|
|           |          | f                    | Ci | Cp  | tc               | I   | A     | tc               | I   | A | tc           | I     | CA    | Q   | Qa  | tc    | I     | CA           | Qp  | L   | S | Vf | S/Do | Qg/Qo | Du/Do  | Vf2/g | Ku         | hu    | Kw   | hw    | Sf   | hf    | dn    | Vn   | m         | m      | m             | m      | m    | m      | m     | m     |  |  |  |  |  |
| 50        | F1/1     | 90                   | 1  | 0.8 | 10               | 228 | 0.134 | 0.126            | 83  | 5 | 290          | 0.127 | 0.111 | 101 | 101 |       |       |              |     |     |   |    |      |       | G1     | 0.025 | 3.37       | 0.083 |      | 0.083 | 0.19 | 0.012 | 0.277 | 1.15 | 13.156    | 13.13  | 14.129        | 14.116 | 14.2 | 14.212 | 0     | F1/1  |  |  |  |  |  |
| 50        | G2/1     | 90                   | 1  | 0.8 | 10               | 228 | 0.117 | 0.114            | 72  | 5 | 290          | 0.111 | 0.11  | 88  | 88  | 3.02  | 0.102 | 0.06         | 0.5 | 2.5 |   |    |      |       | T9/T10 | 0.149 | 1.59       | 0.237 | 1.97 | 0.294 | 1.16 | 0.171 | 0.375 | 1.71 | 13.111    | 13.051 | 13.879        | 13.708 | 14.2 | 14.24  | 0.251 | G2/1  |  |  |  |  |  |
| 50        | 3/1      | 0                    |    |     |                  |     |       |                  |     |   |              |       |       |     |     |       |       |              |     |     |   |    |      |       |        |       |            |       |      |       |      |       |       |      |           |        |               |        |      |        |       |       |  |  |  |  |  |
| 50        | OUT/1    |                      |    |     |                  |     |       |                  |     |   |              |       |       |     |     |       |       |              |     |     |   |    |      |       |        |       |            |       |      |       |      |       |       |      |           |        |               |        |      |        |       |       |  |  |  |  |  |
| 50        | 1/2      | 0                    |    |     |                  |     |       |                  |     |   |              |       |       |     |     |       |       |              |     |     |   |    |      |       | T1/T3  | 0.036 | 0.81       | 0.029 | 0.94 | 0.034 | 0.18 | 0.023 | 0.314 | 1.35 | 13.033    | 12.981 | 14.432        | 14.409 | 14.5 | 14.527 | 0.061 | 1/2   |  |  |  |  |  |
| 50        | 2/2      | 0                    |    |     |                  |     |       |                  |     |   |              |       |       |     |     |       |       |              |     |     |   |    |      |       | T10    | 0.021 | 1.78       | 0.037 | 2.08 | 0.043 | 0.09 | 0.069 | 0.287 | 1.35 | 12.961    | 12.642 | 14.372        | 14.303 | 14.4 | 14.817 | 0.402 | 2/2   |  |  |  |  |  |
| 50        | 3/2      | 0                    |    |     |                  |     |       |                  |     |   |              |       |       |     |     |       |       |              |     |     |   |    |      |       | T3/T6  | 0.058 | 1.33       | 0.077 | 1.5  | 0.087 | 0.24 | 0.07  | 0.398 | 1.52 | 12.622    | 12.506 | 14.226        | 14.156 | 14.3 | 14.51  | 0.138 | 3/2   |  |  |  |  |  |
| 50        | 4/2      | 0                    |    |     |                  |     |       |                  |     |   |              |       |       |     |     |       |       |              |     |     |   |    |      |       | T1/T3  | 0.095 | 0.99       | 0.094 | 1.17 | 0.111 | 0.39 | 0.089 | 0.488 | 1.56 | 12.486    | 12.396 | 14.062        | 13.973 | 14.2 | 14.305 | 0.132 | 4/2   |  |  |  |  |  |
| 50        | 5/2      | 0                    |    |     |                  |     |       |                  |     |   |              |       |       |     |     |       |       |              |     |     |   |    |      |       | T3/T6  | 0.117 | 1.42       | 0.166 | 1.6  | 0.187 | 0.42 | 0.304 | 0.675 | 3.67 | 12.376    | 12.083 | 13.807        | 13.503 | 14   | 13.994 | 0     | 5/2   |  |  |  |  |  |
| 50        | 6/2      | 0                    |    |     |                  |     |       |                  |     |   |              |       |       |     |     |       |       |              |     |     |   |    |      |       | T1/T3  | 0.497 | 1.13       | 0.562 | 1.28 | 0.636 | 1.81 | 0.276 | 0.675 | 4    | 12.063    | 12     | 12.941        | 12.658 | 13.6 | 13.577 | 0     | 6/2   |  |  |  |  |  |
| 50        | OUT/2    |                      |    |     |                  |     |       |                  |     |   |              |       |       |     |     |       |       |              |     |     |   |    |      |       |        |       |            |       |      |       |      |       |       |      |           |        |               |        |      |        |       |       |  |  |  |  |  |
| 50        | 1/3      | 0                    |    |     |                  |     |       |                  |     |   |              |       |       |     |     |       |       |              |     |     |   |    |      |       | T3/T6  | 0.037 | 1.38       | 0.051 | 1.54 | 0.058 | 0.15 | 0.017 | 0.6   | 2.12 | 12.54     | 12.495 | 14.129        | 14.112 | 14.2 | 14.817 | 0     | 1/3   |  |  |  |  |  |
| 50        | 2/3      | 0                    |    |     |                  |     |       |                  |     |   |              |       |       |     |     |       |       |              |     |     |   |    |      |       | T3/T6  | 0.065 | 1.32       | 0.086 | 1.5  | 0.098 | 0.27 | 0.054 | 0.6   | 3.33 | 12.475    | 12.396 | 14.026        | 13.973 | 14.1 | 14.124 | 0     | 2/3   |  |  |  |  |  |
| 50        | G1/4     | 90                   | 1  | 0.8 | 10               | 228 | 0.064 | 0.063            | 40  | 5 | 290          | 0.061 | 0.06  | 49  | 214 | 3.55  | 0.135 | 0.11         | 0.5 | 2.5 |   |    |      |       | G1     | 0.077 | 2.54       | 0.196 |      | 0.196 | 0.6  | 0.014 | 0.13  | 4    | 13.061    | 12.847 | 14.317        | 14.303 | 14.5 | 14.551 | 0.038 | G1/4  |  |  |  |  |  |
| 50        | G1/5     | 90                   | 1  | 0.8 | 10               | 228 | 0.173 | 0.169            | 107 | 5 | 290          | 0.164 | 0.162 | 131 | 131 | 3.524 | 0.116 | 0.08         | 0.5 | 2.5 |   |    |      |       | G1     | 0.04  | 2.68       | 0.106 |      | 0.106 | 0.31 | 0.017 | 0.222 | 1.43 | 12.9      | 12.861 | 14.172        | 14.156 | 14.3 | 14.41  | 0.132 | G1/5  |  |  |  |  |  |
| 50        | G1/6     | 90                   | 1  | 0.8 | 10               | 228 | 0.112 | 0.11             | 70  | 5 | 290          | 0.106 | 0.105 | 85  | 302 |       | 0.125 |              |     |     |   |    |      |       | G1     | 0.051 | 2.44       | 0.125 |      | 0.125 | 0.4  | 0.011 | 0.302 | 1.16 | 12.739    | 12.728 | 14.112        | 14.123 | 14.2 | 14.248 | 0     | G1/6  |  |  |  |  |  |
| 50        | G1/7     | 90                   | 1  | 0.8 | 10               | 228 | 0.072 | 0.071            | 45  | 5 | 290          | 0.069 | 0.068 | 55  | 246 |       | 0.102 |              |     |     |   |    |      |       | G1     | 0.053 | 2.44       | 0.13  |      | 0.13  | 0.41 | 0.022 | 0.375 | 2.23 | 12.755    | 12.733 | 14.134        | 14.112 | 14.3 | 14.264 | 0     | G1/7  |  |  |  |  |  |
| 50        | G1/8     | 90                   | 1  | 0.8 | 10               | 228 | 0.108 | 0.105            | 67  | 5 | 290          | 0.102 | 0.101 | 81  | 115 | 3.847 | 0.113 | 0.07         | 0.5 | 2.5 |   |    |      |       | G1     | 0.029 | 2.5        | 0.072 |      | 0.072 | 0.23 | 0.024 | 0.322 | 1.14 | 12.125    | 12.083 | 13.527        | 13.503 | 13.6 | 13.599 | 0     | G1/8  |  |  |  |  |  |
| 50        | G1/9     | 90                   | 1  | 0.8 | 10               | 228 | 0.078 | 0.077            | 48  | 5 | 290          | 0.074 | 0.073 | 59  | 59  | 2.968 | 0.092 | 0.05         | 0.5 | 2.5 |   |    |      |       | G1     | 0.015 | 2.57       | 0.038 |      | 0.038 | 0.11 | 0.009 | 0.195 | 1.02 | 12.113    | 12.083 | 13.512        | 13.503 | 13.5 | 13.586 | 0.037 | G1/9  |  |  |  |  |  |
| 50        | 22/AA    | 90                   | 1  | 0.8 | 10               | 228 | 0.016 | 0.016            | 10  | 5 | 290          | 0.015 | 0.015 | 12  | 73  |       |       |              |     |     |   |    |      |       | G1     | 0.009 | 3.88       | 0.036 |      | 0.036 | 0.07 | 0.006 | 0.159 | 1.06 | 15.543    | 15.501 | 16.42         | 16.415 | 16.5 | 16.91  | 0.454 | 22/AA |  |  |  |  |  |
| 50        | 21/AA    | 90                   | 1  | 0.8 | 10               | 228 | 0.081 | 0.08             | 50  | 5 | 290          | 0.077 | 0.076 | 61  | 84  |       |       |              |     |     |   |    |      |       | T3/T6  | 0.037 | 1.53       | 0.037 | 1.85 | 0.068 | 0.29 | 0.027 | 0.23  | 1.32 | 15.481    | 15.425 | 16.358        | 16.331 | 16.4 | 16.914 | 0.488 | 21/AA |  |  |  |  |  |
| 50        | 20/AA    | 0                    |    |     |                  |     |       |                  |     |   |              |       |       |     |     |       |       |              |     |     |   |    |      |       | T1/T3  | 0.075 | 1.06       | 0.08  | 1.27 | 0.096 | 0.12 | 0.023 | 0.588 | 2.5  | 14.6      | 14.5   | 16.251        | 16.228 | 16.3 | 17.653 | 1.306 | 20/AA |  |  |  |  |  |
| 50        | 19/AA    | 0                    |    |     |                  |     |       |                  |     |   |              |       |       |     |     |       |       |              |     |     |   |    |      |       | T5/T8  | 0.075 | 1.28       | 0.096 | 1.34 | 0.101 | 0.12 | 0.017 | 0.572 | 2.59 | 14.48     | 14.4   | 16.132        | 16.115 | 16.2 | 17.673 | 1.14  | 19/AA |  |  |  |  |  |
| 50        | 18/AA    | 0                    |    |     |                  |     |       |                  |     |   |              |       |       |     |     |       |       |              |     |     |   |    |      |       | T1/T2  | 0.075 | 1.25       | 0.091 |      | 0.091 | 0.12 | 0.044 | 0.569 | 2.6  | 14.38     | 14.17  | 16.096        | 16.052 | 16.1 | 18.533 | 2.418 | 18/AA |  |  |  |  |  |
| 50        | 17/AA    | 0                    |    |     |                  |     |       |                  |     |   |              |       |       |     |     |       |       |              |     |     |   |    |      |       | T2/T5  | 0.075 | 1.54       | 0.041 |      | 0.041 | 0.12 | 0.015 | 0.552 | 2.7  | 14.15     | 14.07  | 16.011        | 15.996 | 16.1 | 18.503 | 2.515 | 17/AA |  |  |  |  |  |
| 50        | 16/AA    | 0                    |    |     |                  |     |       |                  |     |   |              |       |       |     |     |       |       |              |     |     |   |    |      |       | T2/T5  | 0.075 | 0.61       | 0.045 |      | 0.045 | 0.12 | 0.04  | 0.473 | 3.31 | 14.05     | 13.68  | 15.951        | 15.912 | 16   | 17.974 | 1.978 | 16/AA |  |  |  |  |  |
| 50        | 15/AA    | 0                    |    |     |                  |     |       |                  |     |   |              |       |       |     |     |       |       |              |     |     |   |    |      |       | T1/T3  | 0.118 | 1.37       | 0.162 | 1.58 | 0.187 | 0.19 | 0.099 | 0.582 | 3.16 | 13.66     | 13.22  | 15.75         | 15.65  | 15.9 | 16.702 | 0.766 | 15/AA |  |  |  |  |  |
| 50        | 14/AA    | 0                    |    |     |                  |     |       |                  |     |   |              |       |       |     |     |       |       |              |     |     |   |    |      |       | T5/T8  | 0.073 | 0.53       | 0.039 | 0.56 | 0.041 | 0.1  | 0.02  | 0.584 | 2.89 | 13.2      | 13.07  | 15.612        | 15.592 | 15.7 | 15.798 | 1.146 | 14/AA |  |  |  |  |  |
| 50        | 13/AA    | 0                    |    |     |                  |     |       |                  |     |   |              |       |       |     |     |       |       |              |     |     |   |    |      |       | T2/T5  | 0.073 | 0.69       | 0.05  |      | 0.05  | 0.1  | 0.022 | 0.613 | 2.71 | 13.05     | 12.93  | 15.542        | 15.52  | 15.6 | 15.701 | 1.09  | 13/AA |  |  |  |  |  |
| 50        | 12/AA    | 0                    |    |     |                  |     |       |                  |     |   |              |       |       |     |     |       |       |              |     |     |   |    |      |       | T3/T6  | 0.063 | 1.75       | 0.11  | 1.94 | 0.122 | 0.09 | 0.015 | 0.7   | 2.74 | 12.91     | 12.82  | 15.41         | 15.395 | 15.5 | 15.595 | 0.663 | 12/AA |  |  |  |  |  |
| 50        | 11/AA    | 0                    |    |     |                  |     |       |                  |     |   |              |       |       |     |     |       |       |              |     |     |   |    |      |       | T5/T8  | 0.105 | 1.11       | 0.116 | 1.14 | 0.12  | 0.15 | 0.037 | 0.731 | 2.59 | 12.8      | 12.685 | 15.279        | 15.242 | 15.4 | 15.503 | 1.04  | 11/AA |  |  |  |  |  |
| 50        | 10/AA    | 0                    |    |     |                  |     |       |                  |     |   |              |       |       |     |     |       |       |              |     |     |   |    |      |       | T1/T2  | 0.104 | 0.21       | 0.022 |      | 0.022 | 0.15 | 0.036 | 0.886 | 2.06 | 12.665    | 12.604 | 15.22         | 15.184 | 15.2 | 15.351 | 1.09  | 10/AA |  |  |  |  |  |
| 50        | 9/AA     | 0                    |    |     |                  |     |       |                  |     |   |              |       |       |     |     |       |       |              |     |     |   |    |      |       | T3/T6  | 0.109 | 1.7        | 0.082 | 1.9  | 0.207 | 0.15 | 0.021 | 0.983 | 1.88 | 12.584    | 12.556 | 14.999        | 14.978 | 15.2 | 15.289 | 0.803 | 9/AA  |  |  |  |  |  |
| 50        | 8/AA     | 0                    |    |     |                  |     |       |                  |     |   |              |       |       |     |     |       |       |              |     |     |   |    |      |       | T2/T5  | 0.161 | 0.65       | 0.104 |      | 0.104 | 0.2  | 0.102 | 1.22  | 2.04 | 12.536    | 12.433 | 14.874        | 14.772 | 15   | 15.405 | 0.427 | 8/AA  |  |  |  |  |  |
| 50        | 7/AA     | 0                    |    |     |                  |     |       |                  |     |   |              |       |       |     |     |       |       |              |     |     |   |    |      |       | T1/T3  | 0.166 | 0.43       | 0.072 | 0.49 | 0.081 | 0.2  | 0.035 | 1.243 | 2.04 | 12.413    | 12.379 |               |        |      |        |       |       |  |  |  |  |  |



Main data table with columns: LOCATION, CATCHMENT PROPERTIES, FULL AREA RUNOFF, PART AREA RUNOFF, INLET DESIGN, DRAIN DESIGN, HEADLOSSES, PART FULL, DESIGN LEVELS. Contains rows for various structures and catchments.

Footer section containing REVISION table, DRAWN/DESIGN info, STATUS (FOR CONSTRUCTION), CLIENT (ECONOMIC DEVELOPMENT QUEENSLAND), PROJECT (CARSELDINE URBAN VILLAGE STAGE 1), DRAWING TITLE (STORMWATER DRAINAGE MAJOR CALCULATION TABLES SHEET 6 OF 6), and DRAWING No (15-003002.01).



DISCLAIMER ALL DIMENSIONS TO BE CHECKED ON SITE BY CONTRACTOR PRIOR TO CONSTRUCTION. USE WRITTEN DIMENSIONS ONLY. DO NOT SCALE.

15<sup>th</sup> October 2018

Mal McCann  
Calibre Consulting (QLD) Pty Ltd  
PO Box 10349 Adelaide Street  
Brisbane QLD 4000

Via Email: [BrisAdmin@calibreconsulting.co](mailto:BrisAdmin@calibreconsulting.co)

Dear Applicant,

### Queensland Urban Utilities Services Advice Notice

|                            |  |
|----------------------------|--|
| QUU Application Number:    | 18-SRV-36240                                   |
| Applicant Name:            | Mal McCann<br>Calibre Consulting (QLD) Pty Ltd |
| Street Address:            | 532 Beams Road, Carseldine                     |
| Real Property Description: | Lot 322 on SP172124                            |

Proposed service connection/alteration/disconnection type:

|                    |                                     |
|--------------------|-------------------------------------|
| Drinking water     | <input checked="" type="checkbox"/> |
| Non-drinking water | <input type="checkbox"/>            |
| Wastewater         | <input checked="" type="checkbox"/> |

Queensland Urban Utilities provides this Services Advice Notice in response to the request received in September 2018. In accordance with section 99BRAC(3) of the *South East Queensland Water (Distribution and Retail Restructuring) Act 2009*, this Services Advice Notice provides advice about the proposed connection having regard to the connections policy in the Queensland Urban Utilities Water Netserv Plan, the charges and conditions that may apply to the connection and other relevant matters about the connection. All terms used in this Services Advice Notice are defined by reference to the Queensland Urban Utilities Water Netserv Plan.

This Services Advice Notice does not constitute an application for connection, is not an approval to connect to the Queensland Urban Utilities network(s) and does not bind any future Queensland Urban Utilities' decision if the applicant applies for a connection.

Queensland Urban Utilities understands that the proposed development will consist of 178 residential dwellings. As per the request for a Service Advice Notice submitted, a material change of use/reconfiguration of a lot will be applied for as part of this development.

Based on your proposal and discussion with Queensland Urban Utilities officers, the following advice is provided:

## Queensland Urban Utilities Services Advice

### Infrastructure and Design

The project site is within the [name] Priority Development Area (PDA). Development applications for priority development areas are assessed by Economic Development Queensland (EDQ).

The infrastructure funding framework within each PDA is also typically prescribed and managed by EDQ under an Infrastructure Charges Offset Plan (ICOP). The developer should review the current ICOP and development scheme to understand the broader infrastructure obligations specific to this site.

**Note:** Developer Services needs to consult internally with Network Operations (as future owners of the assets) and Strategic Planning prior to EDQ finalising the proposed infrastructure layout.

### Water

The subject site is located at Aspley Reservoir Gravity water pressure zone.

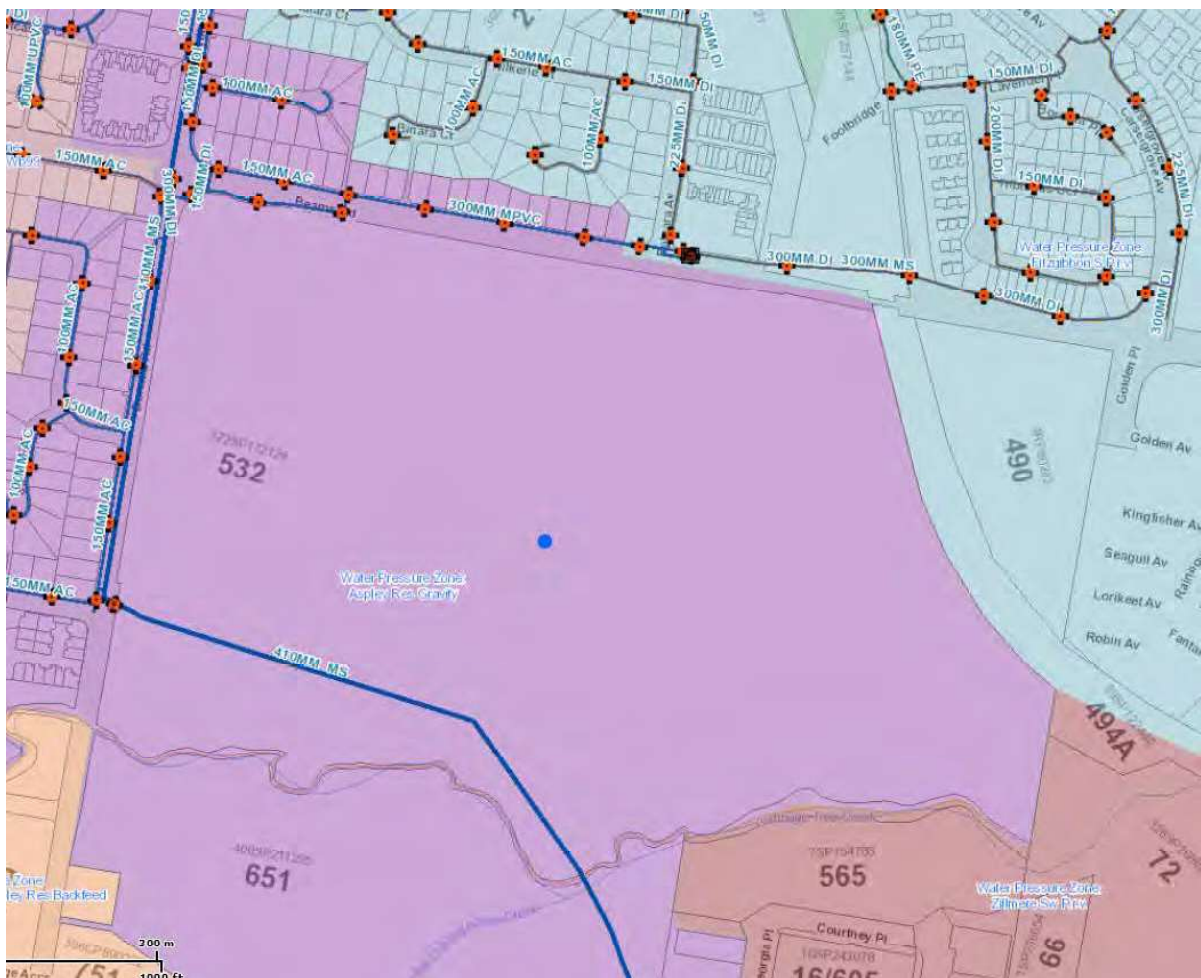

Figure 1: Existing Water infrastructure within the vicinity of the subject site

Calibre Consulting Engineers have proposed to connect the development to the QUU water network at 2 points, as indicated in Attachment 1:

- Point A: On the DN300 MPVC main in Beams Road
- Point B: On the DN150 AC main in Dorville Road

Queensland Urban Utilities does not object to the proposed water service arrangement. Please

note that:

- Connection point A shall be provided on the western side of gate valve RV436569, to ensure the property is contained within a singular pressure zone.
- Connection Point B shall be provided to the existing DN150 AC water main at the western verge of Dorville Road.

### Wastewater

The subject site is currently serviced by connection to the existing DN300 VC trunk sewer at the near side of Beams Road.



Figure 1: Existing Wastewater infrastructure within the vicinity of the subject site

Calibre Consulting Engineers have proposed to connect the development to the existing DN825 concrete trunk sewer main traversing through the property, along the southern property boundary.

Queensland Urban Utilities does not object to the proposed water service arrangement. Please note that, connection shall be provided to a reticulation manhole in parallel to the existing manhole (MH37144) on the trunk main.

Note that the infrastructure required for the proposed development is to be provided in accordance with QUU requirements, including but not limited to the *SEQ Water Supply and Sewerage Design and Construction Code* (SEQ WS&S D&C Code, 2013), or current equivalent.

### Network Demand and Capacity

#### Water

An assessment of the water supply available at the site, including computational hydraulic modelling of the network under peak demand and fire flow conditions, has been completed.

The analysis assumes a Peak Hour Demand of 4.8 L/s (corresponding to the details of the proposed development).

The assessment indicates that the existing water supply network at the vicinity of subject site has sufficient capacity to service the proposed development in accordance with the *SEQ Water Supply and Sewerage Design and Construction Code, 2013 (SEQ WS&S D&C Code)*. The reticulated water supply network proposed within the development should be designed and sized in accordance with the SEQ Code Design Criteria.

Indicative flow and pressure advice for the two proposed connection points on existing DN300 MPVC main in Beams Road and DN150 asbestos cement main in Dorville Road is provided in Table 1, below.

**Table 1: Indicative Flow and Pressure Advice**

| Assumed Connection Main   | Estimated RL Connection (m AHD) | Hydraulic Grade Line (m AHD) |        |        | Pressure (kPa) <sup>1</sup> |        |        |
|---|---------------------------------|------------------------------|--------|--------|-----------------------------|--------|--------|
|   |                                 | 0 L/s                        | 10 L/s | 20 L/s | 0 L/s                       | 10 L/s | 20 L/s |
| Point A – on DN300 MPVC main in Beams Road (constructed in 2015)  | 13.89                           | 65.4                         | 65.3   | 64.9   | 505                         | 504    | 501    |
| Point B – on DN150 AC main in Dorville Road (constructed in 1985) | 22.18                           | 65.4                         | 65.2   | 64.8   | 424                         | 422    | 418    |

**Notes:** <sup>1</sup> Modelled pressure in supply main, relative to the estimated connection RL (m AHD).

<sup>2</sup> Designers are required to adjust the Hydraulic Grade Line/Pressure model results for site/building RL differences and calculate the extra hydraulic losses from point of connection with the main.

<sup>3</sup> Field performance of cast iron spun (or cement) lined mains can be variable. Field testing to ascertain actual pressure drops may be advisable.

<sup>4</sup> Indicative flow and pressure results assume a background demand of 2/3 Peak Hour has been applied throughout the network.

**Disclaimer**

Information provided by Queensland Urban Utilities is based on hydraulic modelling ("Hydraulic Modelling Information"). Model results are for the anticipated performance. **The Hydraulic Modelling Information has not been verified by field measurements and may be inaccurate due to field conditions.**

**As such, users relying on Hydraulic Modelling Information do so at their own risk and should make their own independent investigations to verify model outputs.**

The Hydraulic Modelling Information does not state nor imply a guaranteed level of service. Designers are referred to Queensland Urban Utilities' Customer Charter and Customer Service Standards for facility hydraulic service considerations. **Queensland Urban Utilities does not provide a service of minimum flows and pressures to private fire-fighting systems.**

Due to changing operational circumstances, pressure and flows delivered to a service may vary. Designers are advised to make adequate provisions within the fire system installation for the pressure, flow and reliability requirements, for the life of the system.

A hydraulic assessment of the sewerage network servicing the site under peak wet weather flow conditions has been completed.

The analysis assumes a Peak Wet Weather Flow from the development of 6.0 L/s (corresponding to the details of the proposed development).

The assessment indicates that the localised gravity mains at the vicinity of the subject site have sufficient capacity to service the proposed development.



## Land and Easements

### Sewer Main in Private Properties

Please refer to following link for easement requirements:

<http://www.urbanutilities.com.au/development-services/our-services/building>

### Water Main in Private Properties

Please refer to table 5.2 and clause 5.4.4 of *SEQ WS&S D&C Code* for easement requirements.

## Infrastructure Charges (as at 1 July 2018)

Infrastructure Charges will be levied in accordance with the Queensland Urban Utilities' Water Netserv Plan (Part A) Charges Schedule applicable at the time the water approval application is lodged.

Further information is available at the following website:

<https://www.urbanutilities.com.au/development-services/help-and-advice/water-netserv-plan>

## Trade Waste

A Trade Waste Approval is not required for the proposed development based on the information supplied by the applicant.

## Connection Application Process

A formal assessment as to whether your application qualifies as a Standard Connection, Minor Works Approval, or Major Works Approval will be resolved on application for a Water Approval. For the purposes of preliminary advice, and based on the information provided, it is expected that the following applications will be required to assess the ability to connect to Queensland Urban Utilities networks:

### 1. Network and/or Property Service Connection – Major Works

The Water Approval will require connection works to be undertaken. You will be able to choose which consultants and contractors to appoint to design and construct the works, including live works (in most cases) and then maintain the works for a specified period (usually 12 months) in accordance with the conditions stated in your Water Approval.

Please note that the information provided within this section is subject to the specific aspects of the development and water application.

## Fees and Charges

Queensland Urban Utilities fees and charges are stated in the Queensland Urban Utilities' Water Netserv Plan (Part A) Charges Schedule. The fees and charges that are likely to be associated with these applications are outlined below:

### 1. Application Phase

Base Application Fee – Network (1-10 lots) \$609 (per application for each service)

Fast-track application process (up to 10 lots only) \$2,436 (per application for each service)

Technical Report Review Fee \$602 (per report)

### 2. Design, Construction and Maintenance Phases

#### Design Approval Fee (reticulation)

Property Service Connection Fee \$2,128 (per connection / disconnection / alteration)

Network Connection Type A ( 1–10 lots) \$1,520 (per application for each service)

### Re-checking Amended Plans Fee

Re-checking Amended Plans Fee \$602 per plan

### Works Inspection Fee (reticulation)

Works Inspection Fee Type A \$365 (per inspection)

Works Re-inspection Fee Type A \$547 (per inspection)

#### Notes:

1. The customer may incur additional fees and charges during the approval and works phase, including but not limited to, fees levied by the RPEQ and construction contractor, fees associated with the provision of maintenance / uncompleted works bond(s), re-checking amended plans fees, re-inspection of works fees and infrastructure agreement preparation fees;
2. The above estimates are indicative only and are subject to review of the detailed application upon lodgement; and
3. Please refer to the QUU *Water Netserv Plan* - for further details / clarifications on Fees and Charges.

### Time Frames for Assessment

#### Connection Assessments (for applications other than Standard Connection)

To be completed within 20 business days of receipt of Properly Made Connection Application (including payment of the relevant assessment fee), or within a further 20 business days of receipt of requested information (unless extended by agreement).

#### Design Phase

Typically for an application classified as **major works**, the assessment of the design phase is to be completed within 20 business days of receipt of all designs.

This Services Advice Notice is current for a period of two (2) years from the date of issue. Should you wish to proceed with applying for a service connection please lodge your application via Queensland Urban Utilities Development Services Online Lodgement Portal at <http://www.urbanutilities.com.au/development-services>. Please include your Services Advice Notice reference number in your application.

Queensland Urban Utilities may, at its discretion, provide a reduced fee for a service connection application based on this Services Advice Notice if your application is received within 12 months of the date of issue and is substantially in accordance with the proposal upon which this advice was issued.

If you have any questions in relation to this Service Advice Notice, please do not hesitate to contact your account manager, Vindy Hapuarachchi on 07 3855 6251 or [vindy.hapuarachchi@urbanutilities.com.au](mailto:vindy.hapuarachchi@urbanutilities.com.au).

Alternatively, please email [DCMTenquiries@urbanutilities.com.au](mailto:DCMTenquiries@urbanutilities.com.au).

Yours sincerely



**Toby Turner**

Senior Engineer

Queensland Urban Utilities

15<sup>th</sup> June 2020

Department of Housing & Public Works  
C/- Calibre Consulting (QLD) Pty Ltd  
PO Box 10349 Adelaide Street  
Brisbane QLD 4000

Via Email: [BrisAdmin@calibreconsulting.co](mailto:BrisAdmin@calibreconsulting.co)

Dear Applicant,

### Urban Utilities Water Reticulation Analysis

|                            |  |
|----------------------------|--|
| UU Application Number:     | 20-SRV-46159   |
| Applicant Name:            | Department of Housing & Public Works<br>C/- Calibre Consulting (QLD) Pty Ltd |
| Street Address:            | 532 Beams Road, Carseldine   |
| Real Property Description: | Lot 322 on SP172124  |

Proposed service connection/alteration/disconnection type:

|                    |                                     |
|--------------------|-------------------------------------|
| Drinking water     | <input checked="" type="checkbox"/> |
| Non-drinking water | <input type="checkbox"/>            |
| Wastewater         | <input checked="" type="checkbox"/> |

Urban Utilities provides this Services Advice Notice in response to the request received on 02/06/2020. In accordance with section 99BRAC(3) of the *South East Queensland Water (Distribution and Retail Restructuring) Act 2009*, this Services Advice Notice provides advice about the proposed connection having regard to the connections policy in the Urban Utilities Water Netserv Plan, the charges and conditions that may apply to the connection and other relevant matters about the connection. All terms used in this Services Advice Notice are defined by reference to the Urban Utilities Water Netserv Plan.

This Services Advice Notice does not constitute an application for connection, is not an approval to connect to the Urban Utilities network(s) and does not bind any future Urban Utilities' decision if the applicant applies for a connection.

Urban Utilities understands that the proposed development will consist of 5 stages of residential development including a total of 601 residential multiple dwellings and 3 stages of non-residential development including 7,400 m<sup>2</sup> GFA. As per the request for a Service Advice Notice submitted, a material change of use/reconfiguration of a lot will be applied for as part of this development.

Based on your proposal and discussion with Urban Utilities officers, the following advice is provided:

## Urban Utilities Services Advice

### Background

#### Objective

Calibre Consulting Pty Ltd requested Urban Utilities to prepare a Water and Wastewater Network Analysis Report for the proposed mixed-use development at 532 Beams Road, Carseldine.

The proposed development is located at Brisbane City Council local government area. The site is bounded by Beams Road at north, Dorville Road at west, QR railway corridor at east and Cabbage Tree Creek at south. The proposed development consists of 5 stages of residential development including a total of 601 residential multiple dwellings and 3 stages of non-residential development including 7400 m<sup>2</sup> GFA.

This report includes a review of the necessary water and wastewater network configuration and summarises the modelling assessment undertaken for the proposed development.

#### Water Supply

The development site is located at the Aspley Reservoir Gravity Water Pressure Zone. A map of existing infrastructure is provided in Figure 1.

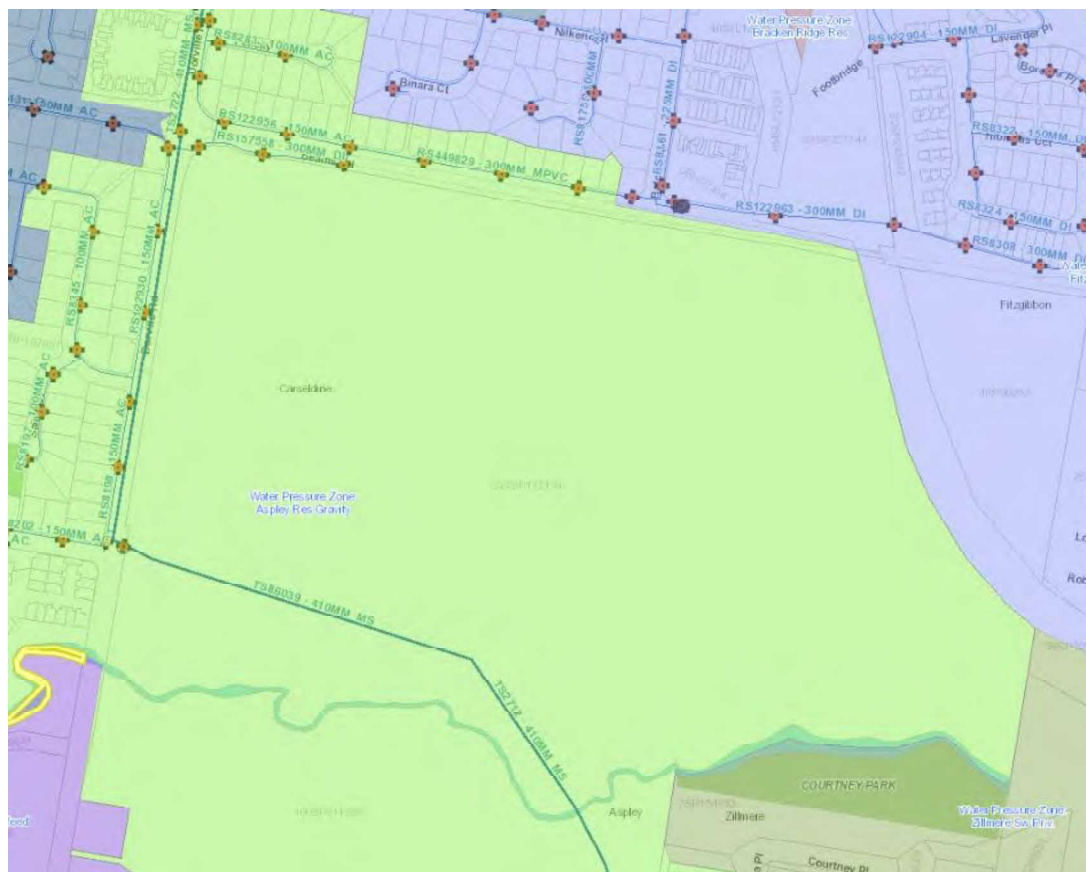

Figure 1 – Development site and surrounding water supply network

Multiple water mains (300mm MPVC /300mm DI/ 150mm AC) in Beams Road and a 150mm AC water main in Dorville Road are available at the vicinity of the site.

The applicant has proposed to service the development from the existing 300 MPVC main in Beams Road. The proposed water layout plan is provided in **Appendix 1**.

### Wastewater:

A 825mm dia trunk sewer main at the western property boundary, a 225mm VC main in Dorville Road and 225mm/ 300mm VC mains in Beams Road are available at the vicinity of the subject site, as indicated in **Figure 2**.

As per the natural ground topography, the proposed development area drains towards the existing 825mm dia. trunk sewer main (Cabbage Tree Creek Main sewer) in S5 catchment.

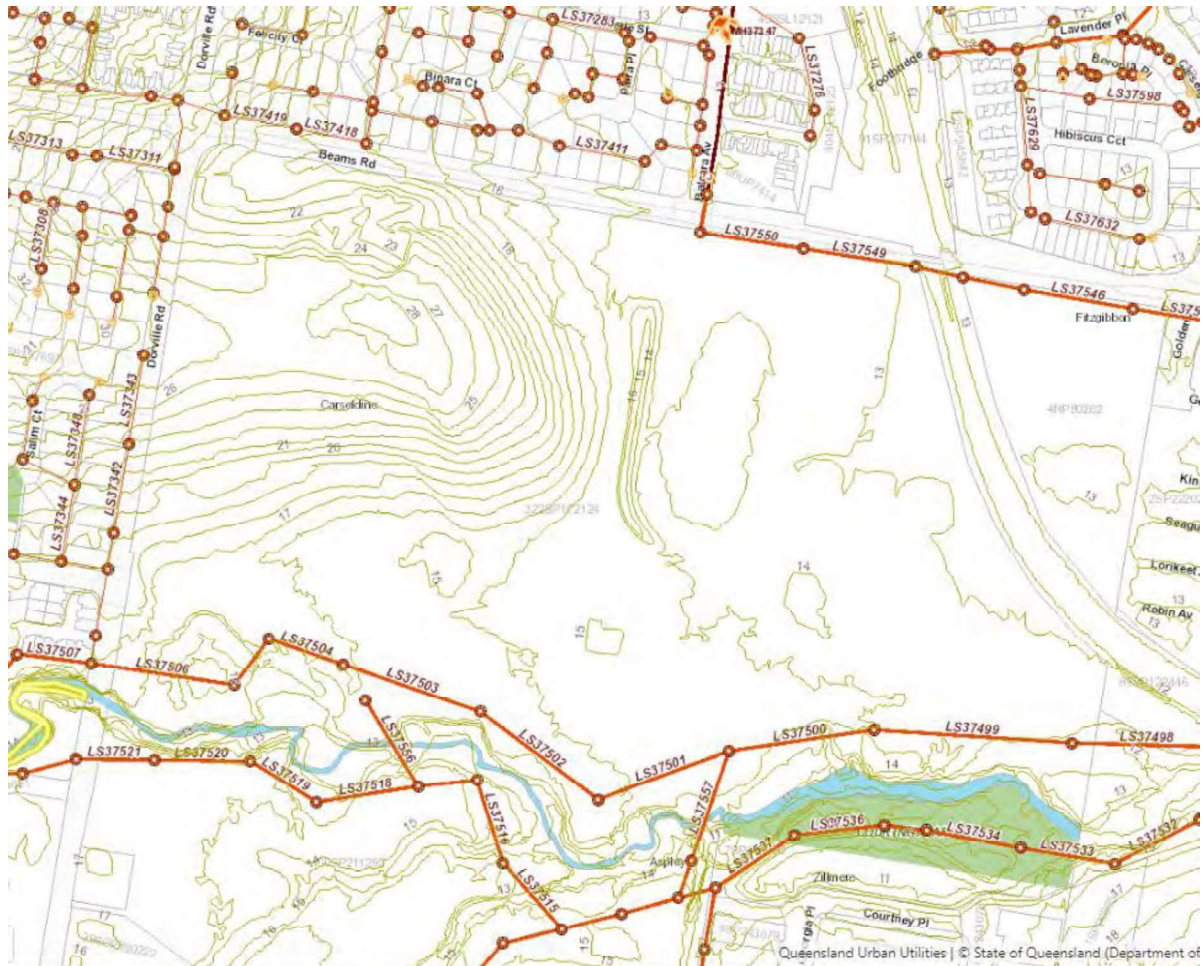

**Figure 2** – Development site and surrounding Sewer network

The applicant has proposed to connect the development to the 825mm dia trunk sewer main at the western property boundary. The proposed wastewater layout plan is provided in **Appendix 1**.

### Design Criteria

#### Development Yield

The proposed development has 601 Residential multiple dwellings and 7400 m<sup>2</sup> GFA of Non-Residential space.

#### Equivalent Persons

The equivalent person (EP) rating of the development site was calculated based on development density factors outlined in Table A4.1, Brisbane City Planning Scheme Development Density of the SEQ WS&S D&C Code (Version 2.0 - February 2020).

The total EP in all stages of the development is calculated as 1,164.1 approximately. A summary of staging and EP calculation is provided below in **Table 1**.

**Table 1: Summary of Staging and EP**

| Residential      | Terrace    | Apartments | Retirement | Total No: of dwellings | EP            |
|------------------|------------|------------|------------|------------------------|---------------|
| Stage 1          | 79         |            | 150        | 229                    | 435.1         |
| Stage 2          | 45         |            |            | 45                     | 85.5          |
| Stage 3          | 57         | 100        |            | 157                    | 298.3         |
| Stage 4          | 20         | 142        |            | 162                    | 307.8         |
| Stage V          |            | 8          |            | 8                      | 15.2          |
| <b>Sub Total</b> | <b>201</b> | <b>250</b> | <b>150</b> | <b>601</b>             | <b>1141.9</b> |
| Non-Residential  | m2 GFA     |            |            |                        | EP            |
| Stages 3, 4 & V  | 7400       |            |            |                        | <b>22.2</b>   |
| <b>Total</b>     |            |            |            |                        | <b>1164.1</b> |

**Water Demands**

The water supply network Design Criteria (outlined in Table 4.1 of the SEQ WS&S D&C Code (Version 2.0 - February 2020) were used to determine the development's respective demands.

- Average Day Demand (AD): 230 L/EP/day
- Non-Revenue Water (NRW): 30 L/EP/day
- Peak Day Demand (PD): 2.0 x AD
- Peak Hour Demand (PH): 4.0 x AD

Based on above criteria, the water demand corresponding to the total EP (1164.1) is as follows:

- Average Day Demand (AD): 3.2 L/s
- Peak Day Demand (PD): 6.4 L/s
- Peak Hour Demand (PH): 12.8 L/s

**Water Supply Network Firefighting Capacity**

The SEQ Code Design Criteria requires provision of firefighting capacity of 25 L/s for greenfield low-density residential areas, 30 L/s for Commercial areas and 60 L/s for high density residential areas.

Considering this is a mixed-use development, 60 L/s firefighting demand was considered with a background demand of 2/3 of residential Peak Hour Demand (PH).

**Sewerage Loading**

The Sewerage network Design Criteria (outlined in Table 10 of the SEQ WS&S D&C Code (Version 2.0 - February 2020) were used to determine the development's respective sewerage loading.

- Average Dry Weather Flow (ADWF) = 210 L/EP/Day
- Peak Wet Weather Flow (PWWF) = 5 x ADWF

The sewerage loading corresponding to the total EP (1164.1) is as follows:

- Average Dry Weather Flow (ADWF) = 2.83 L/s
- Peak Wet Weather Flow (PWWF) = 14.2 L/s

## Water Network Analysis

The existing and proposed water supply network performance was compared to the following guidelines from the SEQ WS&S D&C Code (Version 2.0 - February 2020)

- **Minimum pressure:** Under Peak Hour demands, the residual pressure in the water supply network servicing existing and proposed customers should not fall below 22 metres.
- **Maximum pressure:** A maximum service pressure of 55 metres is permitted.
- **Maximum Velocity:** 2.5 m/s
- **Maximum Allowable Head loss:** 5m/km ( $\leq$ DN150), 3m/km ( $>$ DN150)
- **Firefighting capacity:** Under the identified fire flow event, with a background demand of two-thirds (2/3) Peak Hour, the minimum residual pressure at the flowing hydrant shall be 12 m, with a minimum pressure head of 6 m maintained through the water supply zone.

### Existing network configuration

The proposed development site is located in the Aspley Reservoir Gravity Water Pressure Zone, which is serviced by Aspley Reservoir.

Reservoir details:

- Bottom water level (BWL): 63.09m AHD
- Top water level (TWL): 73.52m AHD

A 1060mm trunk main from Aspley Reservoir is supplying this area, branching off into a 910mm MSC trunk main in Pie Street, a 600mm MSC/ 410mm MS main in Kirby Road, which is supplying the 300mm MS main in Dorville Rd and 300mm DI/MPVC main in Beams Road.

### Water Connection Points

The applicant has proposed to service the development from the existing 300 MPVC water main in Beams Road. Two connections from the development are proposed to this water main. As indicated in **Appendix 1**, Connection 1 is proposed at the boundary between 2 pressure zones (Aspley Res Gravity Pressure Zone and Bracken Ridge Reservoir pressure zone). Connection 2 is at the Aspley Res Gravity Pressure Zone (Refer to Figure 1). Since both connections must be at the same pressure zone, Connection 1 must be provided at the western side of Gate valve RV436569.

### Water Main Sizing

The existing 300 MPVC water main in Beams Road has sufficient capacity to service the development.

Urban Utilities approved water main sizing is provided in **Appendix 1**. As indicated in Appendix 1, the 180mm diameter main should continue between Points A to B and B to C.

Note that the water infrastructure required for the proposed development is to be provided in accordance with Urban Utilities' requirements, including but not limited to the SEQ Water Supply and Sewerage Design and Construction Code (SEQ WS&S D&C Code - Version 2.0 - February 2020), or current equivalent.

## Sewer Network Analysis

### Capacity assessment

The existing 825mm Cabbage Tree Creek main sewer has sufficient capacity to service the development.

The pipe sizing provided in **Appendix 1** have sufficient capacity to service the development. Please

note that the minimum grades are required for all sewer mains within the development.

Note that the wastewater infrastructure required for the proposed development is to be provided in accordance with Urban Utilities' requirements, including but not limited to the SEQ Water Supply and Sewerage Design and Construction Code (SEQ WS&S D&C Code - Version 2.0 - February 2020), or current equivalent.

This Services Advice Notice is current for a period of two (2) years from the date of issue. Should you wish to proceed with applying for a service connection please lodge your application via Urban Utilities Development Services Online Lodgement Portal at <http://www.urbanutilities.com.au/development-services>. Please include your Services Advice Notice reference number in your application.

Urban Utilities may, at its discretion, provide a reduced fee for a service connection application based on this Services Advice Notice if your application is received within 12 months of the date of issue and is substantially in accordance with the proposal upon which this advice was issued.

If you have any questions in relation to this Service Advice Notice, please do not hesitate to contact your account manager, Vindy Hapuarachchi, on 07 3855 6251 or [vindy.hapuarachchi@urbanutilities.com.au](mailto:vindy.hapuarachchi@urbanutilities.com.au).

Alternatively, please email [DCMTenquiries@urbanutilities.com.au](mailto:DCMTenquiries@urbanutilities.com.au).

Yours sincerely



**Sajid Imam Syed**  
Development Assessment Team Leader  
Urban Utilities



PLANS AND DOCUMENTS  
referred to in the PDA  
DEVELOPMENT APPROVAL

Approval no: DEV2019/1074

Date: 26 March 2020



# CARSELDINE URBAN VILLAGE

## UPDATED STORMWATER MANAGEMENT PLAN

DesignFlow

Prepared for Economic Development Queensland

October 2019

**PLANS AND DOCUMENTS  
referred to in the PDA  
DEVELOPMENT APPROVAL**

**Approval no: DEV2019/1074**

**Date: 26 March 2020**



## Document Control Sheet

|                      |   |
|----------------------|---|
| Report Title:        | Carseldine Urban Village – Updated Stormwater Management Plan   |
| Suggested Reference: | Carseldine Urban Village – Updated Stormwater Management Plan (DesignFlow, 2019)                              |
| Version:             | 04  |
| Client:              | Economic Development Queensland   |
| Author(s):           | Ralph Williams  |
| Reviewed By:         | Shaun Leinster  |
| Approved By:         | Shaun Leinster RPEQ15637<br> |
| Date:                | 10/10/2019  |
| File Location:       | S:\Projects\4306  |
| Circulation:         | Electronic Copies: Economic Development Queensland  |

## Disclaimer

This document has been prepared solely for the benefit of the client identified above, and is issued in confidence for the purposes only for which it is supplied. Unauthorised use of this document in any form whatsoever is prohibited. No liability is accepted by DesignFlow Consulting Pty Ltd, or any employee, contractor or sub-consultant of this company with respect to its use by any other person.

This disclaimer shall apply notwithstanding that the document may be made available to other persons for an application for permission or approval to fulfil a legal obligation.

## Qualifications & Limitations

In preparing this report, Designflow has relied upon and assumed accurate data provided by Brisbane City Council (BCC) and other sources. Unless otherwise stated in this report, Designflow has not attempted to verify the accuracy or completeness of any such information. The accuracy of this report is reliant upon the accuracy of this information.

This investigation is based upon BCC's established flood model of the Cabbage Tree Creek floodplain. While some refinements have been made to BCC's models to suit the current project, overall the modelling approach and assumptions have been applied consistently with that of the established models. Consequently, the model accuracy limitations of BCC's flood models also generally apply to this investigation.

Modelling for this investigation is based on a design event approach and assumptions that are consistent with current industry practice. It is important to be aware that real world flood events are random and highly variable. Consequently, observed and future flooding characteristics may not reflect those described in this report.

This report should be read in full and no excerpts are to be taken as representative of the findings. No responsibility is accepted by Designflow for use of any part of this report in any other context.

Study results should not be used for purposes other than those for which they were prepared.

## Table of Contents

|  |           |
|--|-----------|
| EXECUTIVE SUMMARY .....                                | 1         |
| <b>1 SITE CHARACTERISTICS .....</b>                    | <b>3</b>  |
| 1.1 SITE LOCATION.....                                 | 3         |
| 1.2 CLIMATE .....                                      | 3         |
| 1.3 TOPOGRAPHY, CATCHMENTS AND DRAINAGE .....          | 4         |
| 1.4 SOILS AND VEGETATION .....                         | 6         |
| 1.5 PROPOSED DEVELOPMENT .....                         | 6         |
| <b>2 STORMWATER DESIGN OBJECTIVES.....</b>             | <b>8</b>  |
| 2.1 STORMWATER QUALITY .....                           | 8         |
| 2.2 FLOODING .....                                     | 8         |
| <b>3 STORMWATER MANAGEMENT STRATEGY .....</b>          | <b>10</b> |
| 3.1 STORMWATER TREATMENT .....                         | 13        |
| 3.2 FLOOD MANAGEMENT .....                             | 16        |
| <b>4 STORMWATER QUALITY TREATMENT ASSESSMENT .....</b> | <b>17</b> |
| 4.1 MODEL STRUCTURE .....                              | 17        |
| 4.2 RESULTS .....                                      | 19        |
| <b>5 FLOOD ASSESSMENT.....</b>                         | <b>20</b> |
| 5.1 URBS .....   | 20        |
| 5.1.1 <i>PRE-DEVELOPED CATCHMENTS</i> .....            | 20        |
| 5.1.2 <i>DEVELOPED CASE CATCHMENTS</i> .....           | 22        |
| 5.1.3 <i>RAINFALL</i> .....                            | 23        |
| 5.2 TUFLOW .....                                       | 24        |
| 5.2.1 <i>DEVELOPMENT EARTHWORKS</i> .....              | 25        |
| 5.2.2 <i>MITIGATION MEASURES</i> .....                 | 25        |
| 5.3 RESULTS .....                                      | 27        |
| 5.3.1 <i>PEAK FLOWS</i> .....                          | 30        |
| 5.3.2 <i>FLOOD INUNDATION – EXISTING CASE</i> .....    | 30        |
| 5.3.3 <i>FLOOD IMPACTS</i> .....                       | 34        |
| 5.3.4 <i>FLOOD STORAGE</i> .....                       | 36        |
| <b>6 MAINTENANCE.....</b>                              | <b>37</b> |
| 6.1 MAINTENANCE PLAN .....                             | 37        |
| 6.1.1 <i>BIORETENTION BASINS</i> .....                 | 37        |
| <b>7 CONCLUSION.....</b>                               | <b>39</b> |
| <b>8 REFERENCES.....</b>                               | <b>40</b> |
| <b>APPENDIX A – TUFLOW MODEL OUTPUTS.....</b>          | <b>41</b> |

## EXECUTIVE SUMMARY

---

Carseldine Urban Village (Lot 322 on SP172124) is a proposed development on a 45ha site, currently occupied by Queensland Government facilities and community sports fields. The development is currently being undertaken by Economic Development Queensland (EDQ) and involves the creation of lots for a mix of uses including commercial and retail, residential, retirement living and a sporting complex.

This report presents the details of an Updated Stormwater Management Plan for the development to meet the requirements under:

- *State Planning Policy*– SPP (DLGIP, 2017) for the operational stormwater quality objectives;
- *Queensland Urban Drainage Manual* (QUDM) for stormwater quantity management; and
- *Brisbane City Council Planning Scheme*

This report supersedes the previously issued stormwater management plan for the site (DesignFlow, April 2018). This updated stormwater management plan captures the following updates and information that has been made available since the issue of the April 2018 report:

- Updated and approved overall masterplan for the development (source: RPS, October 2019)
- Latest earthworks associated with the development (source: Calibre Consulting, June 2019)
- Existing site pipe drainage survey (completed June 2019 – source: Land Partners)

### STORMWATER QUALITY MANAGEMENT

The updated stormwater treatment strategy includes two (2) bioretention basins that treat development runoff prior to discharge to Cabbage Tree Creek:

- Bioretention Basin B1 265m<sup>2</sup> filter area treating Stages 2, 3 (part of) and S
- Bioretention Basin B2 500m<sup>2</sup> filter area total treating the remainder of the development (Stages 1,3 (part of), 4 and 5)

These basins are located outside of the Cabbage Tree Creek riparian corridor and will have low impact on existing vegetation. The proposed locations also avoid conflicts with the future busway corridor.

Drainage swales along the eastern boundary of the site and at the southern boundary of the Stage S sports fields also provide additional treatment.

## FLOOD MANAGEMENT

Flood impact assessment demonstrates no significant impacts occurring external to the site as a result of development. Some afflux (~50mm) is observed immediately south east of the development boundary, however this afflux occurs within a low-lying flood prone bushland area and is not considered an actionable nuisance.

Improved flood conditions are observed at Beams Road and the rail line at the north-east end of the site. This is because much of the site drainage will be directed to Cabbage Tree Creek. Furthermore, during larger magnitude events, the proposed development fill restricts Cabbage Tree Creek breakout flow from entering this area.

Required mitigation measures to manage flood impacts external to the site include:

- Providing flood storage over the sports field zone for events greater than the 5% AEP (20 year ARI).
- Incorporation of a 1200mm dia pipe with one-way flap valve along the new drainage swale draining the eastern half of the development. This minimizes the impacts of Cabbage Tree Creek flows into the site via this new connection to Cabbage Tree Creek.
- Inclusion of a flood barrier (~1m high) along the eastern boundary of the site. This avoids increases in flood levels along the rail line adjacent to the site.

This report is based on regional flood modelling based upon the Brisbane City Council (BCC) flood model for Cabbage Tree Creek. Updated regional modelling and detailed local modelling will occur as part of continuing design development for the site.

# 1 SITE CHARACTERISTICS

## 1.1 SITE LOCATION

The Carseldine Urban Village development is located approximately 14km north of Brisbane. The site is bounded by Beams road to the north, Cabbage Tree Creek to the south, Brisbane rail to the east and Dorville Road to the west.

Figure 1 shows the location of the site.



Figure 1: Locality plan

## 1.2 CLIMATE

Figure 2 provides a summary of the monthly rainfall based on climate statistics for Brisbane (station No 40223).

The annual average rainfall is 1,190 mm, whilst annual evaporation is approximately 1,950mm. The figure clearly indicates the seasonal nature of rainfall and evaporation with lower rainfall and evaporation periods during the winter months.

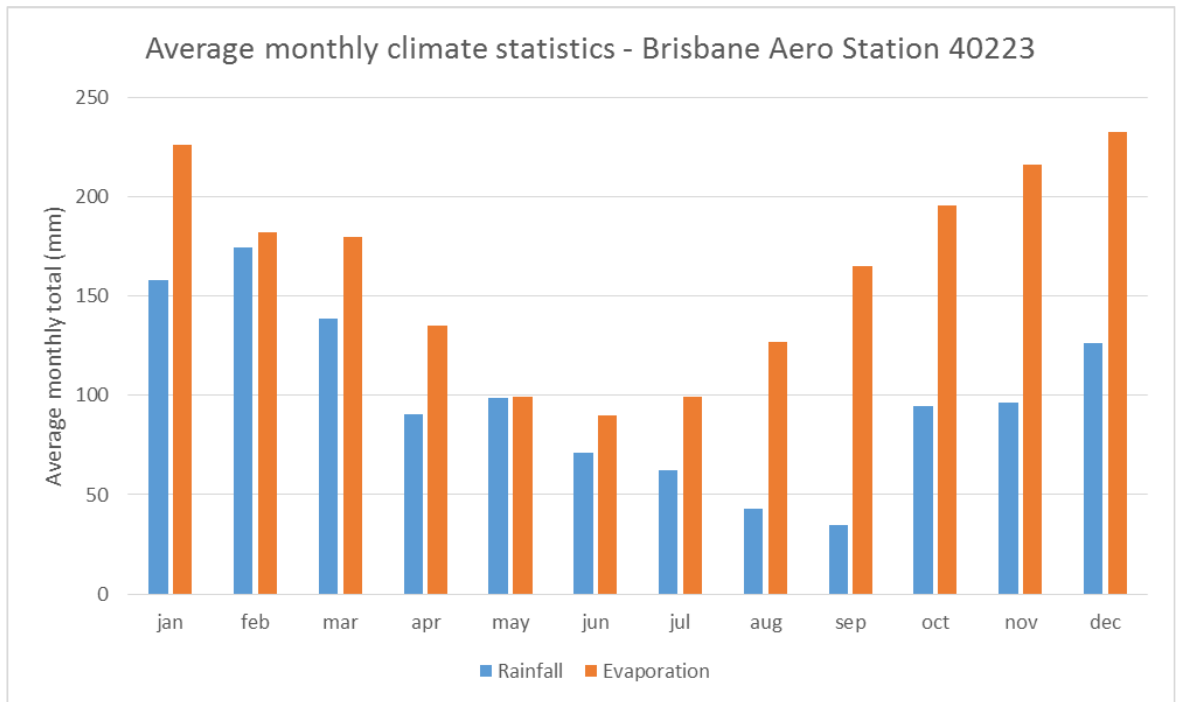

Figure 2 Average monthly climate statistics

### 1.3 TOPOGRAPHY, CATCHMENTS AND DRAINAGE

Ground levels across the site range from approximately RL28 at the high point located at the north western boundary of the development to approximately RL9.5 at the south eastern corner at Cabbage Tree Creek. Grades across the site are flat to moderate typically ranging from 0.5 to 10%.

The site is characterised by areas of low lying and poorly drained topography. Figure 3 shows the existing topography and general drainage of the current site. The majority of the site drainage is toward Cabbage Tree Creek to the south, whilst the north west section of the site drains northward. Poorly drained areas are also noted at the north east of the site.

Pipe drainage within the site discharges at two (2) outfalls to Cabbage Tree Creek. This drainage system minimises localised site flooding in the more frequent events, when regional flooding from Cabbage Tree Creek does not occur.

In general, the northern bank of Cabbage Tree Creek is higher than adjacent ground levels further north within the site. This means flood flows are initially contained within Cabbage Tree Creek but then break out of the banks of the creek over the high point on the northern bank and inundate low lying and poorly drained areas within the site.

At the north eastern end of the site, low lying areas occur adjacent to the rail line and at the northern boundary of the existing sports fields adjacent to Beams Road. This area appears to be providing an overland flow path for flood flows.

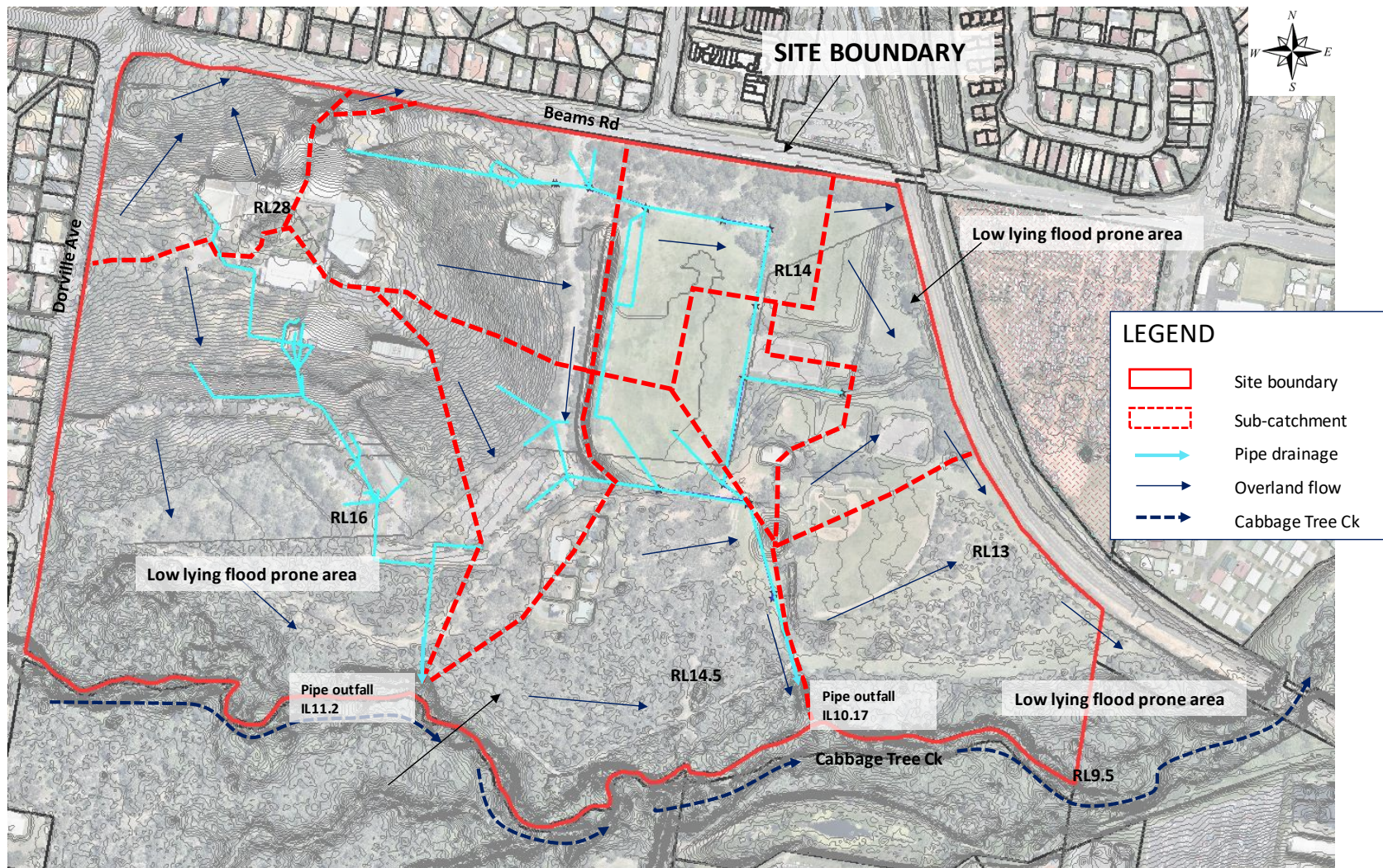

Figure 3: Topography and drainage



#### **1.4 SOILS AND VEGETATION**

Soils across the site are generally characterised by alluvial soils comprising surface clayey silt overlying medium to high plasticity silty clay and sandy clay, with interbedded layers of clayey sand, gravelly sand and gravel (SGS, 2017).

The site comprises of sports fields and government buildings in the northern half of the site. Extensive good value bushland occurs in the southern half of the site including the Cabbage Tree Creek riparian corridor (refer Figure 1).

#### **1.5 PROPOSED DEVELOPMENT**

The Carseldine Urban Village development is located within a 45ha site. The site includes existing government facilities at the north western end of the development that are to be retained. Existing sports fields at the north eastern corner of the site are to be redeveloped, whilst a new sporting precinct will be constructed at the south eastern corner of the site. A future busway is planned at the southern end of the site. The existing QUT research facility at the southern end of the site is planned to be decommissioned in 2020.

The overall development will include approximately 10.3ha of new commercial and residential development, and an approximated 5 ha of new sporting complex area.

The current development layout for Carseldine Urban Village is shown in Figure 4.



Figure 4 Proposed Carseldine Urban Village development (Source: RPS 2019)

## 2 STORMWATER DESIGN OBJECTIVES

---

Stormwater management objectives have been established based on the following:

- *State Planning Policy* (DLGIP, 2017)
- *Queensland Urban Drainage Manual* (2016)
- *Brisbane City Council (BCC) Planning Scheme*

### 2.1 STORMWATER QUALITY

The stormwater quality management objectives that apply to the operational phase of the development are defined in the State Planning Policy (DLGIP, 2017) which applies load based objectives presented in Table 1.

**Table 1 – Stormwater quality objectives**

| Constituent                  | Discharge criteria                               |
|------------------------------|--|
| Total suspended solids (TSS) | 80% reduction in post developed mean annual load |
| Total phosphorous (TP)       | 60% reduction in post developed mean annual load |
| Total nitrogen (TN)          | 45% reduction in post developed mean annual load |
| Gross pollutants             | 90% reduction in post developed mean annual load |

Construction phase erosion and sediment control objectives are outlined in Table A Appendix 2 of SPP (DLGIP, 2017). Detailed erosion and sediment control plans will be provided with the Operational Works application.

### 2.2 FLOODING

The flood management objectives applicable to the site are presented in Table 2. Carseldine Urban Village development lies within Brisbane City Council (BCC) mapped City Wide Waterway corridor zone.

**Table 2 Flood objectives**

| Criterion   | Design Objective   |
|---|--|
| No worsening hydraulic conditions   | No worsening hydraulic impact to be demonstrated external to the site for the critical duration storm for the 39% AEP to 1% AEP events   |
| <p><b><i>BCC flood overlay code PO2</i></b></p> <p>Development within a creek/waterway flood planning area</p>                              | <p>a) Maintains conveyance of flood waters to allow flow and debris to pass predominantly unimpeded through the site</p> <p>b) Does not concentrate, intensify or divert floodwater onto upstream, downstream or adjacent properties</p> <p>c) Will not result in a material increase in flood levels or flood hazard on upstream, downstream or adjacent properties</p> |
| <p><b><i>BCC Flood overlay code PO8</i></b></p> <p>Development for filling or excavation in an area affected by creek/waterway flooding</p> | Does not directly, indirectly or cumulatively cause any material increase in flooding or hydraulic hazard or involve significant redistribution of flood storage from high to lower areas in the floodplain  |

### 3 STORMWATER MANAGEMENT STRATEGY

---

The stormwater management strategy for the Carseldine Urban Village development has been developed based on discussions with EDQ, the design team and field inspections to identify opportunities and constraints.

When developing the strategy, several guiding principles were considered:

- achieve obligations under the *State Planning Policy*, *BCC planning scheme policy* and *Queensland Urban Drainage Manual*
- ensure stormwater management systems are functionally feasible within the constraints of the development and drainage levels
- avoid numerous stormwater management sites
- avoid works within the Cabbage Tree Creek riparian buffer zone
- minimize impacts on existing good value vegetation
- avoid works encroaching into the future busway corridor
- minimize the need for an on-site flood basin, where possible
- utilization of the 10m wide acoustic barrier at the eastern boundary of the site for drainage conveyance and treatment

Figure 5 shows the stormwater management strategy for the Carseldine Urban Village development. The strategy has been developed considering the proposed drainage for the development (source: Calibre Consulting). This includes pipe drainage for minor storm events and overland flows for flows exceeding pipe capacity.

Performance assessments of the proposed management strategy are presented in Section 4 (stormwater quality) and Section 5 (flooding).

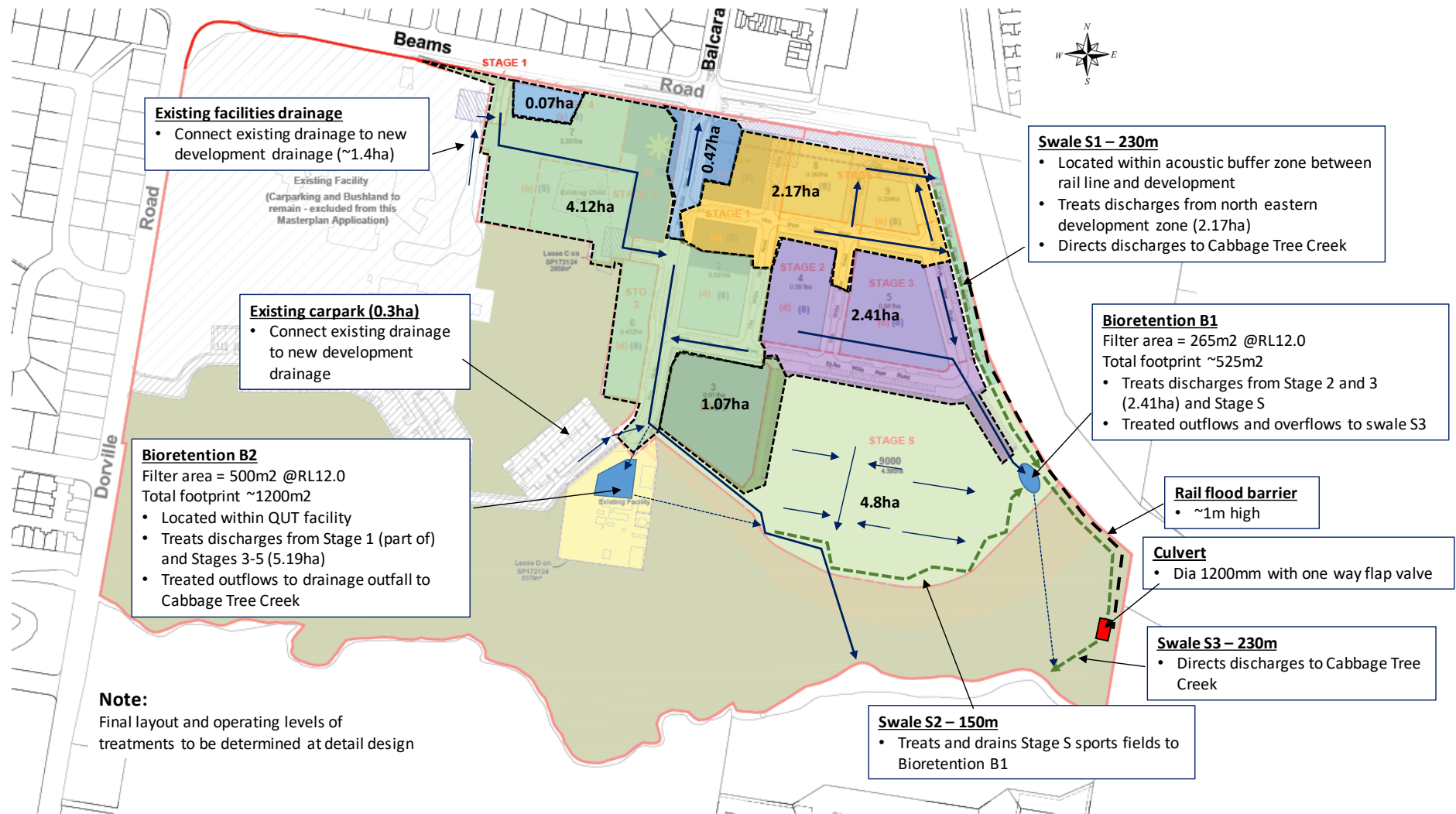

Figure 5 Stormwater Management Strategy Carseldine Urban Village

Table 3 Stormwater treatment elements

| ID and Stages Treated                       | Treatment    |                   | Catchment<br>ha | Comment  |
|---|--------------|-------------------|-----------------|--|
|   | Type         | Area/length       |                 |  |
| B1 – Stages 2,3 (part of) and S             | Bioretention | 265m <sup>2</sup> | 2.41            | Located within Stage S. Treats discharges from Stage 2 and 3 (part of). Receives treated flows from Stage S sports fields. Treated flows and overflows to swale S3.                                |
| B2 – Stages 1 and 3 (part of) and 4-5       | Bioretention | 500m <sup>2</sup> | 5.19            | Located within the QUT facility. Treats Stages 1 and 3 (part of) and Stages 4 and 5. Receives low from diversion from main drainage pipe. Treated outflows to drainage outfall to Cabbage Tree Ck. |
| S1 – Stages 1, 2 and 3 (part of) and 4      | Swale        | 230m              | 2.17            | Treats north eastern development zone (Stage 1, 2 and 3 (part of) and Stage 4).  |
| S2 – Stage S                                | Swale        | 150m              | 4.8             | Treats and drains Stage S sports fields to Bioretention B1   |
| S3 – Stages 1 and 3 (part of) and 2,4 and S | Swale        | 230m              | B1+S1+S2        | Conveys eastern development zone discharges to Cabbage Tree Ck. Provides additional treatment for upstream discharges prior to discharge to Cabbage Tree Creek                                     |
| Stage 1 (part of) – Beams Rd                | untreated    |                   | 0.54            | Development treatment upsized to offset this untreated portion of the development  |
| <b>TOTAL</b>                                |              |                   | <b>15.11</b>    |  |

### 3.1 STORMWATER TREATMENT

The treatment strategy includes two (2) bioretention basins treating the development zones as shown in Figure 5. Swales along the southern boundary of the Stage 5 sports fields and at the eastern boundary of the site will also provide a treatment function prior to discharge to Cabbage Tree Creek.

Two small development areas (0.54ha total) adjacent to Beams Road at the northern end of the development do not report to the treatments proposed. The stormwater treatment proposed as part of this strategy have been sufficiently sized to compensate (i.e. over-treat) for the treatment of this area. Refer to Section 4 for performance assessments.

It should also be noted that the proposed drainage strategy will connect existing drainage from the existing facilities at the north west of the site to drainage that will report to Bioretention basin B2. This provides treatment of an area that previously was untreated.

#### ***Bioretention Basin B1***

Bioretention Basin B1 (filter area 265m<sup>2</sup> at RL12.0) treats Stage 2 development and the eastern Stage 3 development and receives treated discharges from the swale (S2) draining Stage 5 sports fields. This basin is located at the eastern boundary of the site, just south of Stage 5 carpark. Pipe discharges enter the basin from the development zone via the Stage 5 carpark.

Treated outflows from the bioretention basin discharge to swale S3. Overflows from the bioretention connect directly to swale S3 via an overflow weir.

Detail designs for this bioretention basin have now been completed and construction is currently underway as part of Stage 5 works. A general arrangement of the bioretention basin is shown in Figure 6.



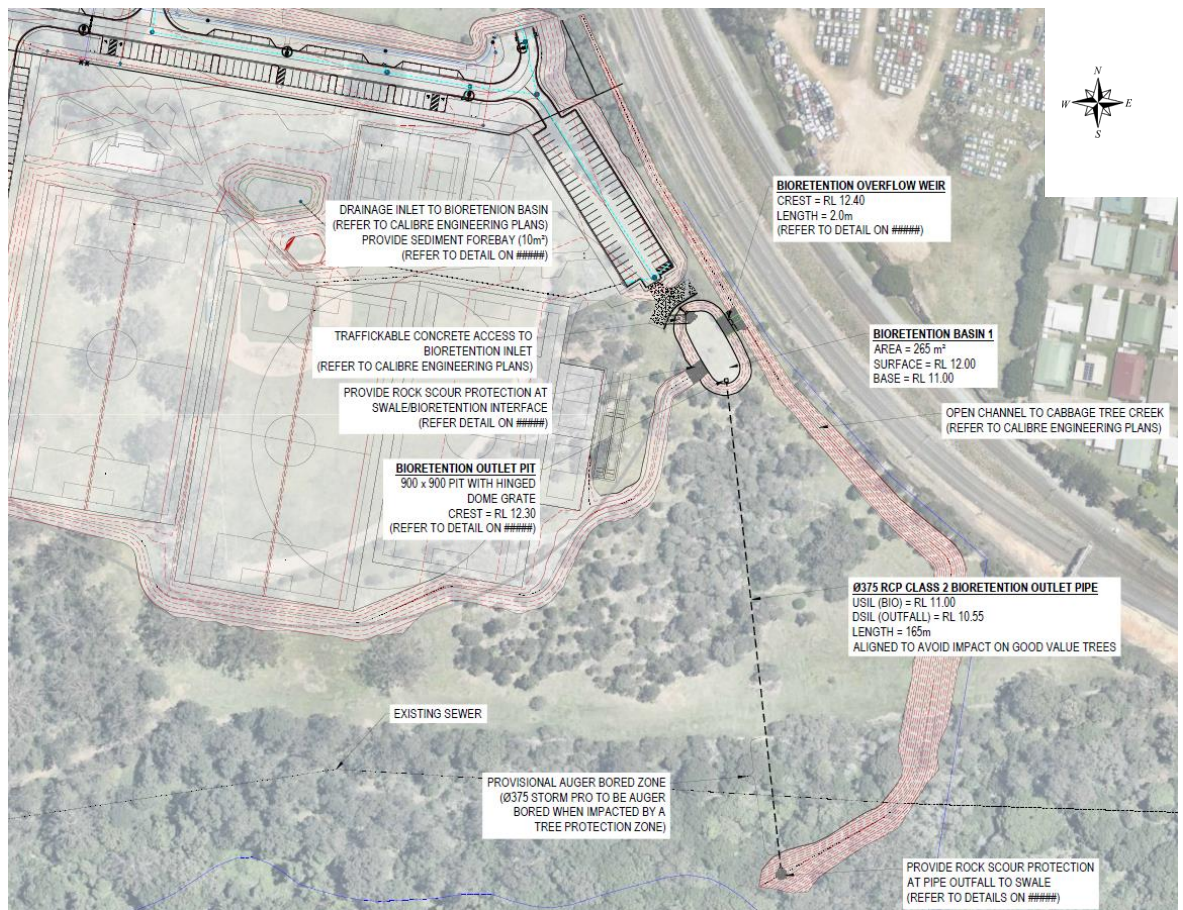

Figure 6 Bioretention basin B1 general arrangement

### Bioretention Basin B2

Bioretention Basin B2 (filter area 500m<sup>2</sup> at RL12.0) treats parts of Stage 1 and 3 (west) development as well as Stages 4 and 5. The basin is proposed to be located within the footprint of the existing QUT research facility at the southern end of the site. This area, covering approximately 6,500m<sup>2</sup>, is due to be decommissioned in 2020.

This treatment site could be incorporated as part of a future stormwater reuse scheme, by directing treated stormwater from the bioretention basin to an adjacent storage pond, which can then be used to supply harvested water for sports field irrigation.

Detail designs have now been completed for this bioretention. A general arrangement is shown in Figure 7.

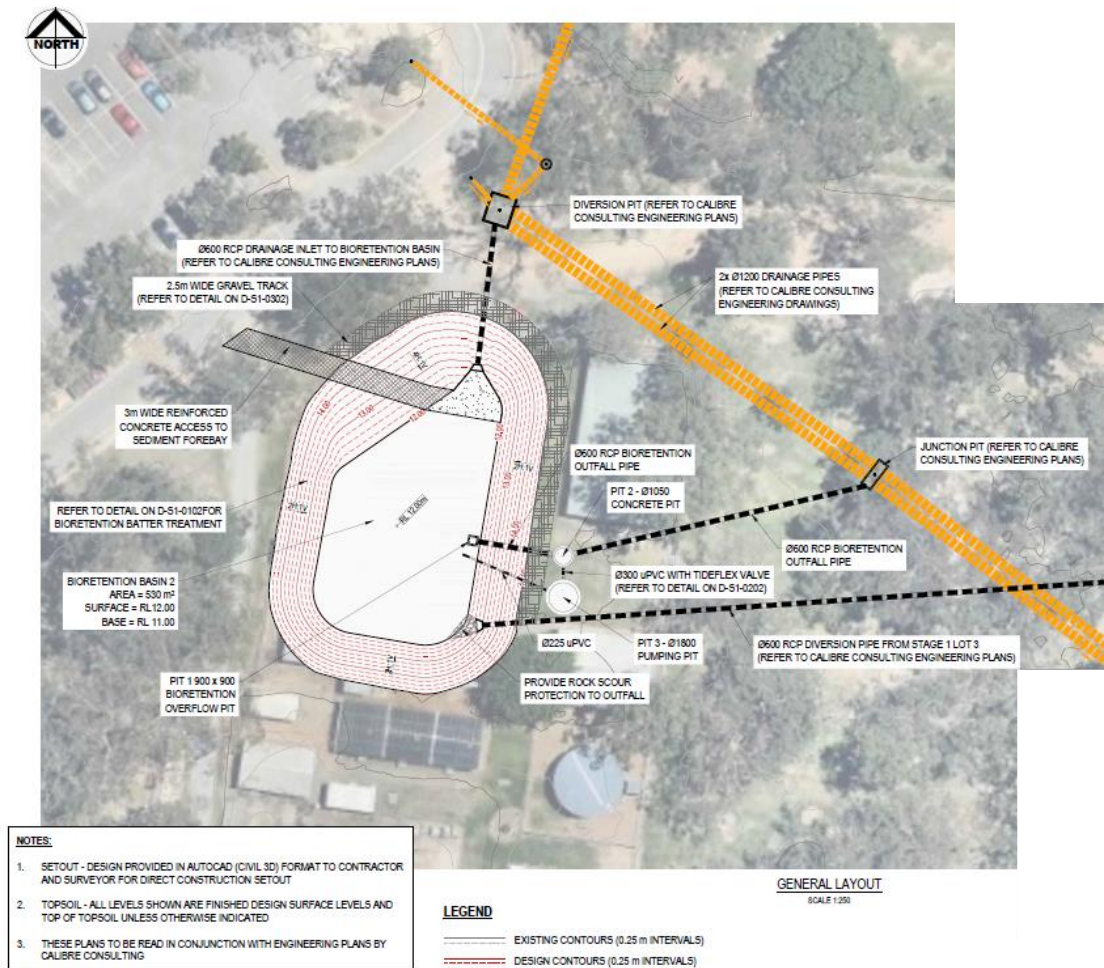

**Figure 7 Bioretention basin B2 general arrangement**

A diversion pit will direct development low flows to the bioretention basin at the northern end. In addition, a diversion pipe (600mm dia) will direct drainage from Stage 1 Lot 3 (1.07ha) to the bioretention basin at the southern end. High flows will continue to the drainage outfall to Cabbage Tree Creek via twin 1200mm dia pipes.

Treated outflows and bioretention overflows will be piped from the bioretention basin to the proposed 2x1200 mm dia drainage outfall pipes to Cabbage Tree Creek. A dia 1800mm pit is included with the bioretention basin works to facilitate connection to a future stormwater harvest scheme, should this proceed. This will allow the retrofit of future pumping infrastructure within this pit to pump bioretention treated outflows to a future holding pond. Regardless, the bioretention basin can operate under gravity to drain treated flows and overflows to the outfall of Cabbage Tree Creek i.e. the bioretention basin is not reliant on the inclusion of a stormwater harvest scheme and can operate entirely independently and under gravity.

### Swale S1 (~230m)

Swale S1 (~230m) represents the drainage reserve formed at the eastern boundary of the development. Drainage from part of Stages 1 to 3 and Stage 4 will discharge to this

drainage reserve. This area is a minimum 10m wide and will be grassed and treed to form a buffer to the rail corridor. Drainage gradients along this zone are typically flat (~0.3%).

#### ***Swale S2 (~150m)***

Swale S2 receives and treats drainage from the Stage S sports fields and directs this drainage to Bioretention Basin B1. This swale is turfed with 6H:1V batters. Drainage gradients are typically 0.6%.

#### ***Swale S3 (~230m)***

Swale S3 connects drainage from the eastern half of the development zone to Cabbage Tree Creek. To minimise the impact on vegetation within the Cabbage Tree Creek riparian zone, batter slopes of 3H:1V are used. Drainage gradients along this zone are typically 0.6%. The swale will be vegetated with a mix of groundcovers and riparian vegetation to provide a treatment function and aid stability.

### **3.2 FLOOD MANAGEMENT**

The majority of development runoff is directed southward to discharge to Cabbage Tree Creek. Development earthworks are configured to facilitate overland flows eastward and southward to allow the majority of development drainage to Cabbage Tree Creek. Developed lots are above 1% AEP levels (Q<sub>100</sub>), however the sports field earthworks allow flooding of the sports fields in events higher than the 5% AEP (Q<sub>20</sub>). This aids in offsetting loss of flood storage as a result of development and avoids flood impacts along Cabbage Tree Creek.

A new swale along the eastern boundary of the site drains stormwater from the eastern half of the site to Cabbage Tree Creek. A 1200mm dia culvert is included along this swale with a one-way flap valve to minimise backwatering effects of Cabbage Tree Creek flows into the development from this new swale.

A flood barrier is also included along the eastern boundary of the site to contain development flows within the site and avoid impacts along the rail corridor. This flood barrier can take the form of a low block wall (~1m high) and/or bund and can be incorporated with the future acoustic fence along this boundary. Further details are provided in Section 5.2.2.

## 4 STORMWATER QUALITY TREATMENT ASSESSMENT

MUSIC modelling was conducted to quantitatively assess the stormwater treatment performance of the proposed stormwater treatment strategy. MUSIC version 6.3 was used for the assessment and the parameters have been established in accordance with the MUSIC Modelling Guidelines for South East Queensland (Water by Design, 2010).

Details of the modelling assumptions, parameters used and results are presented in the following sections.

### 4.1 MODEL STRUCTURE

The structure of the MUSIC model is shown in Figure 8 with the general data upon which the model is based provided in Table 4.

Catchments have been derived from the proposed masterplan layout, considering the pipe drainage system that would apply (refer to Figure 5 previously). Only areas under development are included in the model.

The model adopts a lumped catchment approach.

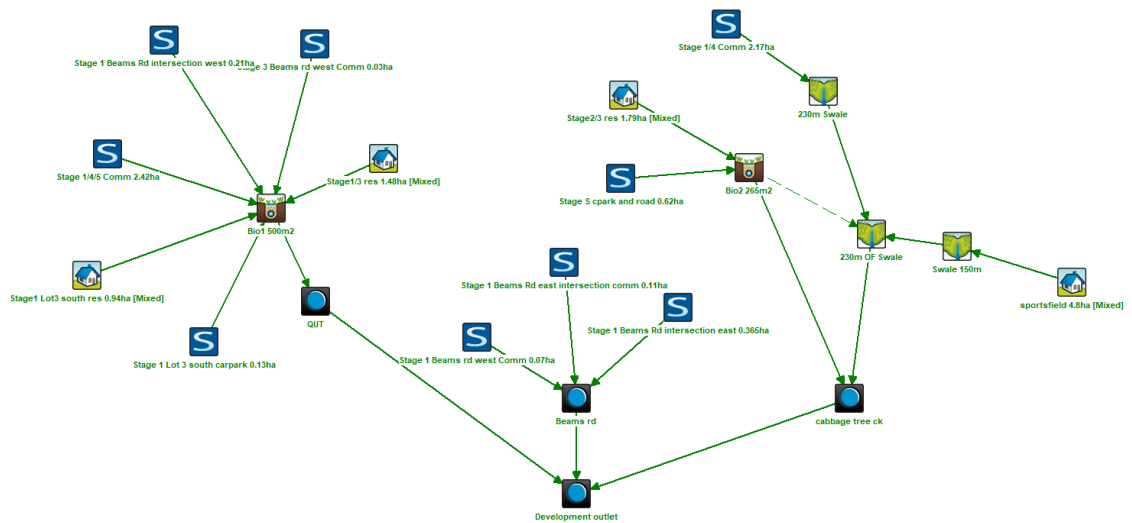

Figure 8 MUSIC model

**Table 4 MUSIC model data summary**

| Parameter   | Value  |
|---|--|
| <b>Source Data</b>  |  |
| Rainfall data set   | 1990-1900 – Brisbane Aero Station No. 40223  |
| Modelled time step  | 6 minute   |
| Mean annual rainfall 1980--1990   | 1155 mm (for the period used)  |
| Potential evapotranspiration  | 1,526mm (Table 3.1 Music modelling guidelines for SEQ)   |
| Soil properties (runoff generation parameters)                          | Table 3.7 Music Modelling Guidelines for SEQ   |
| Pollutant concentrations (base and storm flow concentration parameters) | Table 3.9 Music Modelling Guidelines for SEQ   |
| Percent impervious  | Table 3.6 Music Modelling Guidelines for SEQ<br>Residential/mixed use (50dw/ha): 80% impervious<br>Retail/commercial: 90% impervious<br>Road: 90% impervious   |
| <b>Treatment Devices</b>  |  |
| Bioretention  | Filter media depth = 0.6 m<br>Extended detention depth = 0.3 m<br>Seepage = 0 mm/hr<br>Saturated hydraulic conductivity 200mm/hr<br>TN content <sup>1</sup> 400 mg/kg<br>Orthophosphate content <sup>1</sup> 30mg/kg |
| Swale   | Base width = 1m<br>Top width = 10m<br>Depth = 0.5m (S1 and S2); 1.5m (S3)<br>Vegetation height = 0.05m (S1 and S2); 0.25m (S3)<br>Slope 0.3% (S1); 0.6% (S2 and S3)  |

**Note:**

1. Water By Design have recently completed a review of important default values for bioretention basins. In terms of bioretention the parameters adopted are consistent with new values for filter media OP and TN content recently adopted by Healthy Waterways

## 4.2 RESULTS

The results of the MUSIC modelling are presented in Table 5.

**Table 5 Summary of MUSIC modelling – Carseldine Urban Village**

| Treatment ID                            | Pollutant  | Inflows (kg/yr) | Outflows (kg/yr) | Reduction achieved (%) | Water quality objective  |
|---|------------|-----------------|------------------|------------------------|--|
| <b>CARSELDINE URBAN VILLAGE</b>         |            |                 |                  |                        |  |
| Bio B1<br>Filter area 265m <sup>2</sup> | TSS        | 5720            | 802              | 86.0                   | Water quality objective applies to the combined site discharge |
|   | TP         | 10.8            | 2.2              | 79.7                   |  |
|   | TN         | 65.6            | 26.7             | 59.2                   |  |
| Bio B2<br>Filter area 500m <sup>2</sup> | TSS        | 11000           | 1910             | 82.6                   |  |
|   | TP         | 25.0            | 6.08             | 75.7                   |  |
|   | TN         | 151             | 66.7             | 55.8                   |  |
| Swale S1<br>Length = 230m               | TSS        | 4660            | 535              | 88.5                   |  |
|   | TP         | 12.2            | 3.44             | 71.9                   |  |
|   | TN         | 70.5            | 50.4             | 28.5                   |  |
| Swale S2<br>Length = 150m               | TSS        | 1570            | 654              | 58.2                   |  |
|   | TP         | 4.06            | 2.48             | 39.1                   |  |
|   | TN         | 32.6            | 27.6             | 15.3                   |  |
| Swale S3<br>Length = 230m               | TSS        | 1950            | 1200             | 38.4                   |  |
|   | TP         | 7.75            | 6.41             | 17.3                   |  |
|   | TN         | 94.5            | 86.2             | 8.8                    |  |
| Stage 1 – Beams Rd<br>0.54ha untreated  | TSS        | 1820            | 1820             | 0                      |  |
|   | TP         | 3.45            | 3.45             | 0                      |  |
|   | TN         | 17.4            | 17.4             | 0                      |  |
| <b>TOTAL</b>                            | <b>TSS</b> | <b>24700</b>    | <b>4970</b>      | <b>80.0</b>            | <b>80</b>  |
|   | <b>TP</b>  | <b>55.6</b>     | <b>16.3</b>      | <b>70.7</b>            | <b>60</b>  |
|   | <b>TN</b>  | <b>337</b>      | <b>181</b>       | <b>46.4</b>            | <b>45</b>  |

The results demonstrate that load based objectives are achieved for the Carseldine Urban Village Development with the proposed stormwater treatment strategy.

## 5 FLOOD ASSESSMENT

---

Flood modelling has been based on Brisbane City Council (BCC) supplied URBS and TUFLOW regional flood models for Cabbage Tree Creek. These models have been updated as necessary to make suitable for an impact assessment of the Carseldine Urban Village development.

The following describes model updates made to the Council supplied URBS and TUFLOW models to complete assessments on the impacts of the development.

### 5.1 URBS

URBS has been used to generate flows for the pre-developed and developed case scenarios for incorporation into TUFLOW. The following describes the model updates and assumptions used.

#### 5.1.1 Pre-developed catchments

The Council supplied URBS model includes 70 sub catchments that delineate the approximate 43.1km<sup>2</sup> Cabbage Tree Creek catchment. URBS catchments covering the Carseldine Urban Village development zone within the Cabbage Tree Creek catchment have been refined to allow better representation of local catchment flooding characteristics in and around the development.

Sub-catchment 29 in the URBS model covers the proposed Carseldine Urban Village development zone. This has been split into 5 sub-catchments (291 to 295) to represent in finer detail site drainage based on existing topography obtained from Council supplied DEM model and ground truthing of current drainage.

Pervious and impervious fractions have been updated for these catchments, together with catchment slopes. Catchment slopes have been updated and estimated using the equal area method for each new sub catchment modelled.

All other URBS catchments have been retained as per the original Council supplied model setup, including catchment slopes.

Figure 9 shows the predeveloped catchments relevant to the Carseldine Urban Village development. Table 6 provides a summary of sub-catchment land uses, areas and slopes modelled in and around the development. URBS model land use is applied by using various land use categories within each sub-catchment. URBS model land use categorisation has been adopted in accordance with the BCC model. Land use categories and associated fractions impervious values are:

- Urban Low Density (10% Impervious)
- Urban Medium Density (50% Impervious)
- Urban High Density (90% Impervious)
- Rural (0% Impervious)

Table 6 Pre-developed catchments

| ID  | Area<br>ha | Land use (%)   |                   |                 |       | Catchment<br>Slope % |
|-----|------------|----------------|-------------------|-----------------|-------|----------------------|
|     |            | Low<br>density | Medium<br>density | High<br>density | Rural |                      |
| 291 | 18.63      | 0%             | 0%                | 18.0%           | 82.0% | 1.14                 |
| 292 | 6.57       | 0%             | 0%                | 9.7%            | 90.3% | 2.04                 |
| 293 | 6.52       | 0%             | 0%                | 3.6%            | 96.4% | 0.63                 |
| 294 | 5.09       | 0%             | 0%                | 0%              | 100%  | 0.55                 |
| 295 | 82.15      | 0%             | 19.3%             | 38.3%           | 42.4% | 0.70                 |
| 32  | 36.52      | 0%             | 83.3%             | 3.8%            | 12.8% | 1.30                 |

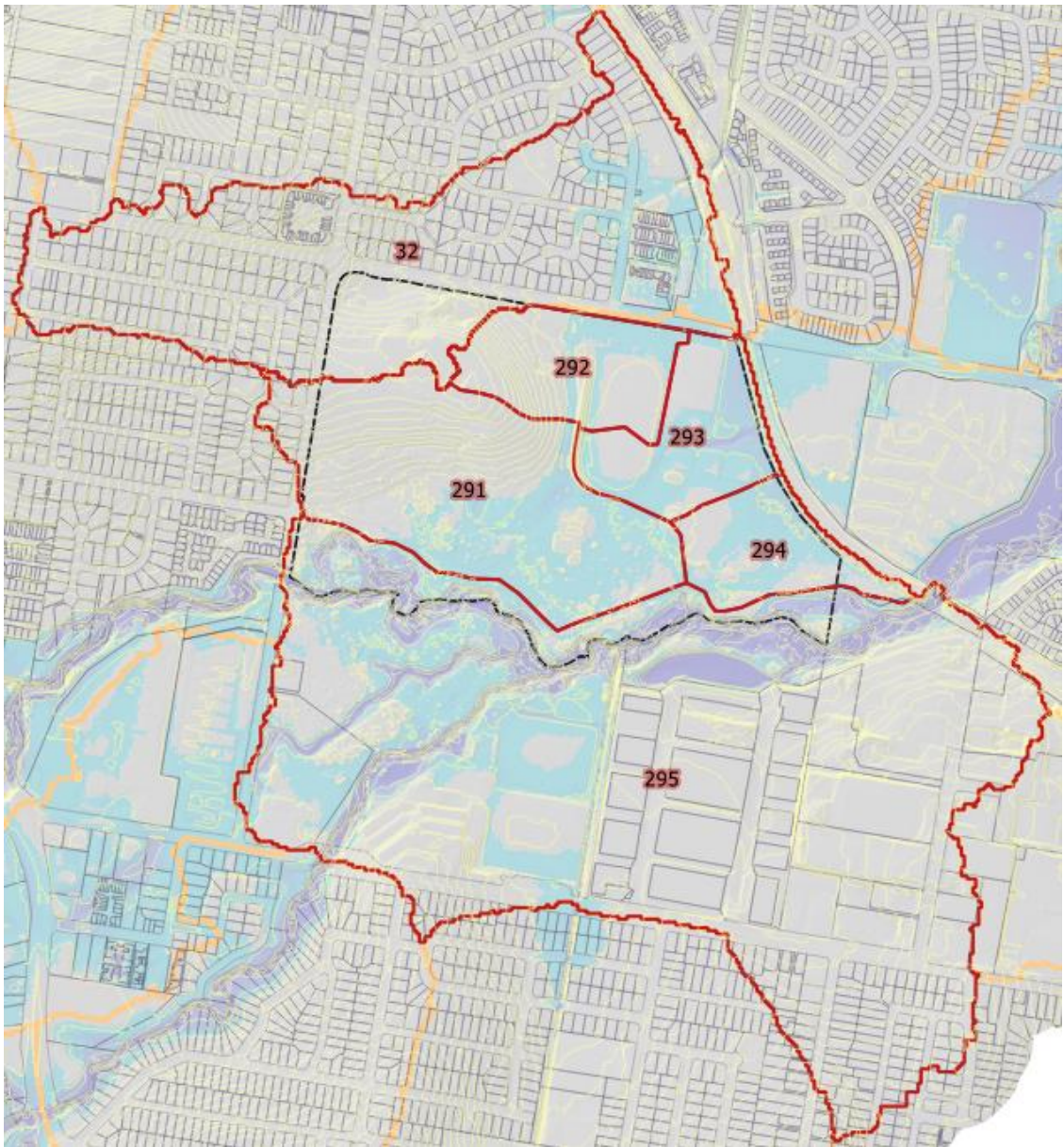

Figure 9 Refined URBS sub-catchments relevant to the development – base case



### 5.1.2 Developed case catchments

Sub-catchments where development applies were adjusted to represent the proposed development for Carseldine Urban Village. This applies to sub catchments 291, 292, 293, 294 and 32. These sub-catchments are shown in Figure 10.

Catchment land uses have been adjusted to account for the increased impervious area associated with the development. Adjustments to sub-catchment boundaries have also been applied, where necessary to align with the drainage strategy of the developed site.

Sub-catchments 293 and 294 drain southwards to Cabbage Tree Creek via a new drainage swale between the railway line and the development. Sub-catchments 291 and 292 will drain to Cabbage Tree Creek via stormwater pipes that will discharge in the vicinity of the two existing outfalls. The final details of this drainage configuration will be undertaken as part of future detail design phases.

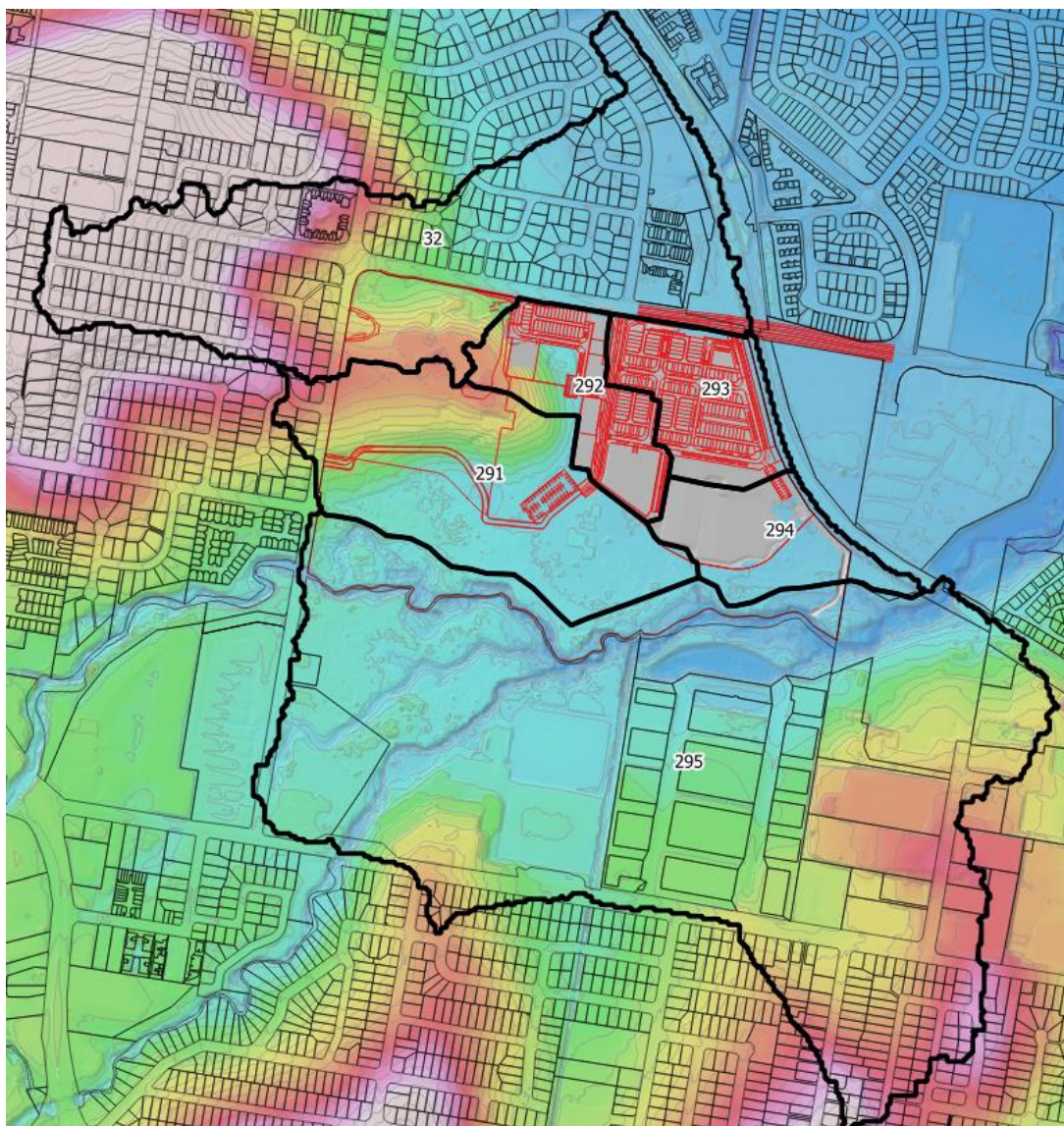

Figure 10 Developed case sub-catchments

Pervious and impervious areas were derived based on expected fraction impervious values for the various land uses. Percent impervious values applied to each land use were based on recommended values in QUDM (2007). The following values have been applied:

- pre-developed vegetation: 0%
- Urban residential: 90%
- Retail/commercial: 90%
- Sports fields: 0%

Modelled catchment areas and slopes for post developed conditions are summarised in Table 7.

**Table 7 Carseldine Urban Village development - modelled catchment areas and slopes**

| ID  | Area<br>ha | Land use (%)   |                   |                 |        | Catchment<br>Slope % |
|-----|------------|----------------|-------------------|-----------------|--------|----------------------|
|     |            | Low<br>density | Medium<br>density | High<br>density | Rural  |                      |
| 291 | 17.98      | 0%             | 0%                | 16.11%          | 83.89% | 1.14                 |
| 292 | 6.63       | 0%             | 0%                | 88.00%          | 12.00% | 2.04                 |
| 293 | 6.47       | 0%             | 0%                | 87.83%          | 12.17% | 0.63                 |
| 294 | 6.01       | 0%             | 0%                | 1.78%           | 98.22% | 0.55                 |
| 295 | 82.15      | 0%             | 19.28%            | 38.3%           | 42.4%  | 0.70                 |
| 32  | 36.24      | 0%             | 83.98%            | 3.87%           | 12.15% | 1.30                 |

### 5.1.3 Rainfall

Design event modelling has been undertaken using Australian Rainfall and Runoff (ARR, 1987) industry standard approach of modelling multiple design rainfall burst durations and extracting the maximum values from these events.

Rainfall parameters were based on the following:

- Temporal Patterns were based on the Australian Rainfall and Runoff (1987) publication. Zone 3 is applied to this site.
- Rainfall Intensity Frequency Duration (IFD) data used is consistent with that used in previous modelling, based on AR&R.

Design storms for the 39%, 20%, 10%, 5%, 2% and 1% AEP events have been modelled for the 60, 90, 120, 180 and 360 minute duration storms.

Design event rainfall is retained as per the Council supplied URBS model.

#### ***Rainfall losses and roughness values***

Loss rates are retained as per the Council supplied URBS model. The following loss rates are used for the pervious areas for all events modelled:

- initial loss – 10 mm
- continuing loss – 0mm/hr

Zero initial and continuing loss is applied to the impervious fractions.

## 5.2 TUFLOW

Flood modelling has been carried out using a refined version of BCC's Cabbage Tree Creek TUFLOW model. The following updates have been made to the model for this investigation:

- The model has been updated to a recent version of TUFLOW (2016-03-AE\_64\_iSP\_w64)
- Inflow hydrographs have been extracted from the refined URBS sub-catchments.
- TUFLOW 'gully' lines have been incorporated to improve model representation of local gullies in the study area. In particular, the existing drain adjacent to the railway has been modelled using a 'gully' line.
- Inflow hydrographs from the refined URBS sub-catchments have been applied using 2d\_sa polygons that have been trimmed to control where flows are input to the TUFLOW model.
- The major drainage pipes associated with the two existing outfalls to Cabbage Tree Creek have been incorporated using 1D pipe elements

Existing stormwater drainage pipes and inlets pits within the site have been incorporated into the pre-developed case TUFLOW model as shown in Figure 11. This is based in recent survey of the existing pipe infrastructure (June 2019). Pipe diameters are shown in metres in Figure 11.

All other model parameters and assumptions remain unchanged.

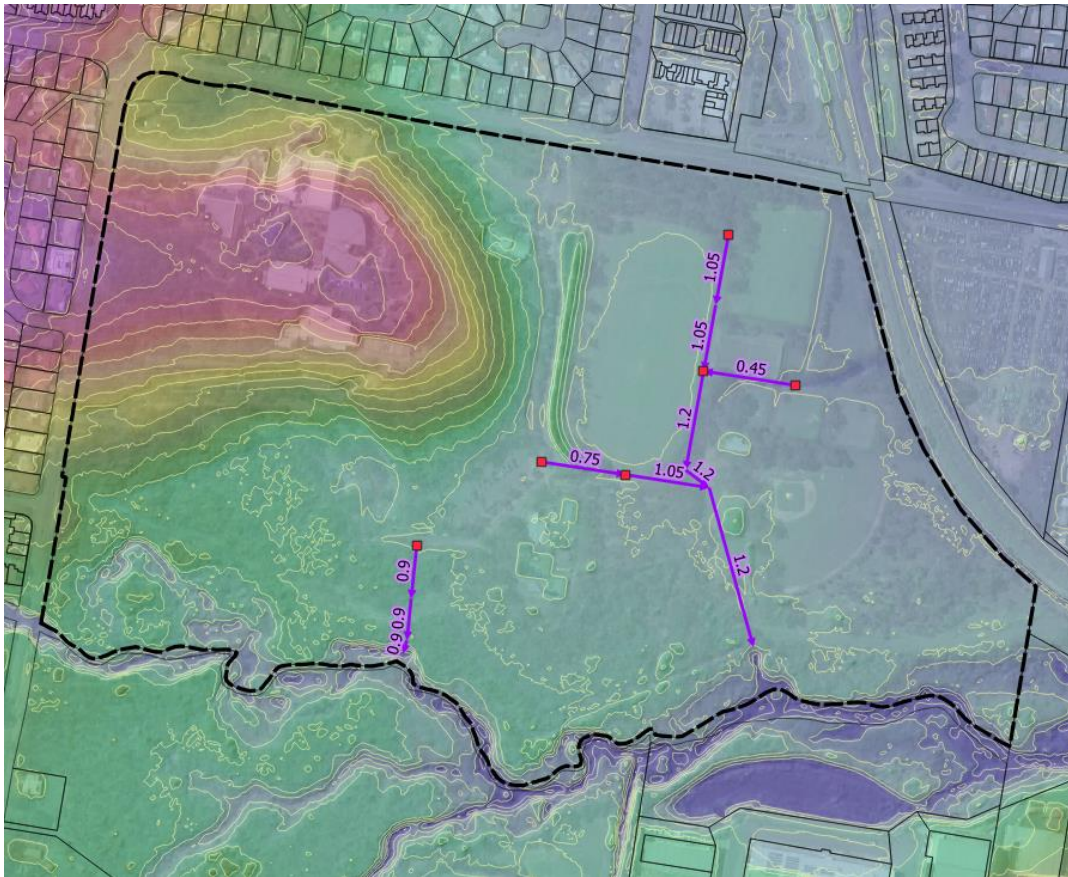

Figure 11 Existing site pipe drainage

### 5.2.1 Development earthworks

The proposed development has been incorporated into the TUFLOW model based on the latest earthworks design tin provided by the project civil engineers (Calibre Consulting).

### 5.2.2 Mitigation measures

Extensive iterative model assessments identified the following mitigation measures were required to avoid impacts external to the site:

- Sports field earthworks are designed to allow flooding during less frequent events (5% AEP and above)
- A 1200mm diameter culvert with a flood valve is included along the proposed eastern swale to minimize backwatering from Cabbage Tree Creek into the development via this swale – this minimizes the impacts of Cabbage Tree Creek flows into the site via this new connection to Cabbage Tree Creek.
- The rail corridor external to the property boundary will be protected from any increase in flood levels through the incorporation of an engineered flood barrier (~1m high) along the eastern boundary of the site - this avoids increases in flood levels external to the site adjacent to the rail line.

Details of the above mitigation measures are provided in Figure 12.

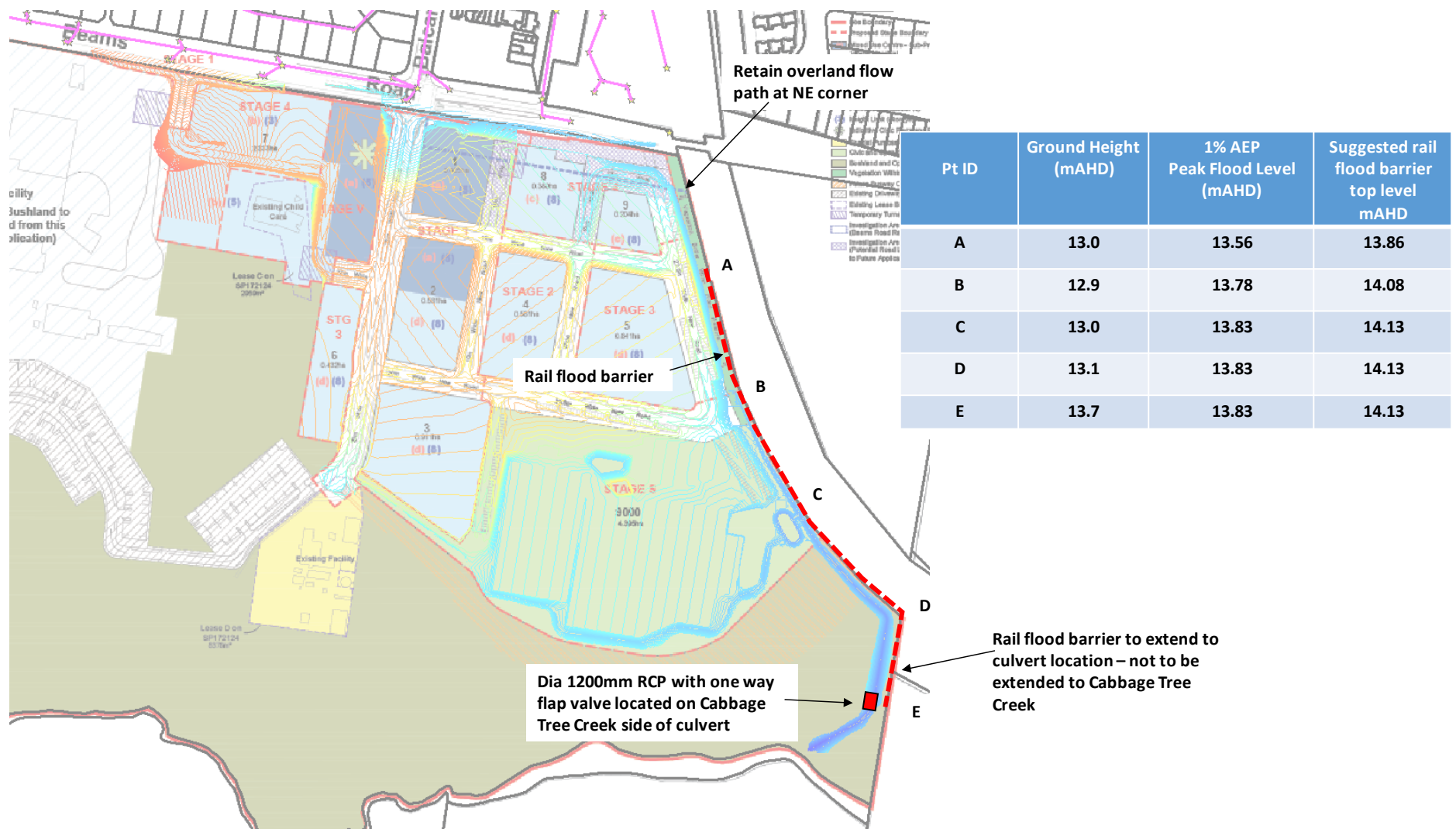

Figure 12 Proposed mitigation measures

The proposed rail flood barrier along the eastern boundary can take the form of a low blockwork wall and/or an earthen bund where space permits. This barrier can be combined with the future acoustic fence along the eastern boundary of the site e.g. the bottom of the acoustic fence takes the form of a blockwork wall with the acoustic fence installed above.

The extent and minimum flood levels for the flood barrier are provided Figure 12. This provides a 300mm freeboard to the expected 100 year developed flood levels. It should be noted that the flood barrier extends to the 1200mm dia culvert at the southern end and not to Cabbage Tree Creek to avoid constraining Cabbage Tree Creek flood flows and causing flood impacts downstream. The existing overland flow path at the north eastern end of the site is retained i.e. the rail flood barrier does not extend all the way to Beams Road.

### 5.3 RESULTS

Table 8 summarises peak flows immediately upstream of the Railway Bridge at Cabbage Tree Creek (reporting point 10), whilst Table 9 summarises peak water levels for pre and post conditions at various reporting location both within and external to the site. Figure 13 provides locations of reporting points.

Appendix A provides flood depth and impact maps for model runs. These include:

- Figure A1: Base case 39%AEP (Q<sub>2</sub>) flood depth
- Figure A2: Base case 5% AEP (Q<sub>20</sub>) flood depth
- Figure A3: Base case 1% (Q<sub>100</sub>) flood depth
- Figure A4: Developed case 39% AEP (Q<sub>2</sub>) flood depth
- Figure A5: Developed case 5% AEP (Q<sub>20</sub>) flood depth
- Figure A6: Developed case 1% AEP (Q<sub>100</sub>) flood depth
- Figure A7: Flood impact map 39% AEP (Q<sub>2</sub>)
- Figure A8: Flood impact map 20%AEP (Q<sub>5</sub>)
- Figure A9: Flood impact map 10% AEP (Q<sub>10</sub>)
- Figure A10: Flood impact map 5% AEP (Q<sub>20</sub>)
- Figure A11: Flood impact map 2% AEP (Q<sub>50</sub>)
- Figure A12: Flood impact map 1% AEP (Q<sub>100</sub>)
- Figure A13: Regional flood impact map 39% AEP (Q<sub>2</sub>)
- Figure A14: Regional flood impact map 1% AEP (Q<sub>100</sub>)

Table 8 Peak flows – Cabbage Tree Creek - Railway Bridge (Point 10)

| AEP       | Peak flow (m <sup>3</sup> /s) |        |            | Difference % |
|-----------|-------------------------------|--------|------------|--------------|
|           | Pre                           | Post   | Difference |              |
| 39% (Q2)  | 74.80                         | 74.66  | -0.14      | -0.2%        |
| 20% (Q5)  | 103.39                        | 103.54 | 0.15       | 0.1%         |
| 10% (Q10) | 122.74                        | 122.59 | -0.15      | -0.1%        |
| 5% (Q20)  | 146.77                        | 147.19 | 0.42       | 0.3%         |
| 2% (Q50)  | 176.57                        | 176.68 | 0.11       | 0.1%         |
| 1% (Q100) | 202.1                         | 202.8  | 0.70       | 0.3%         |

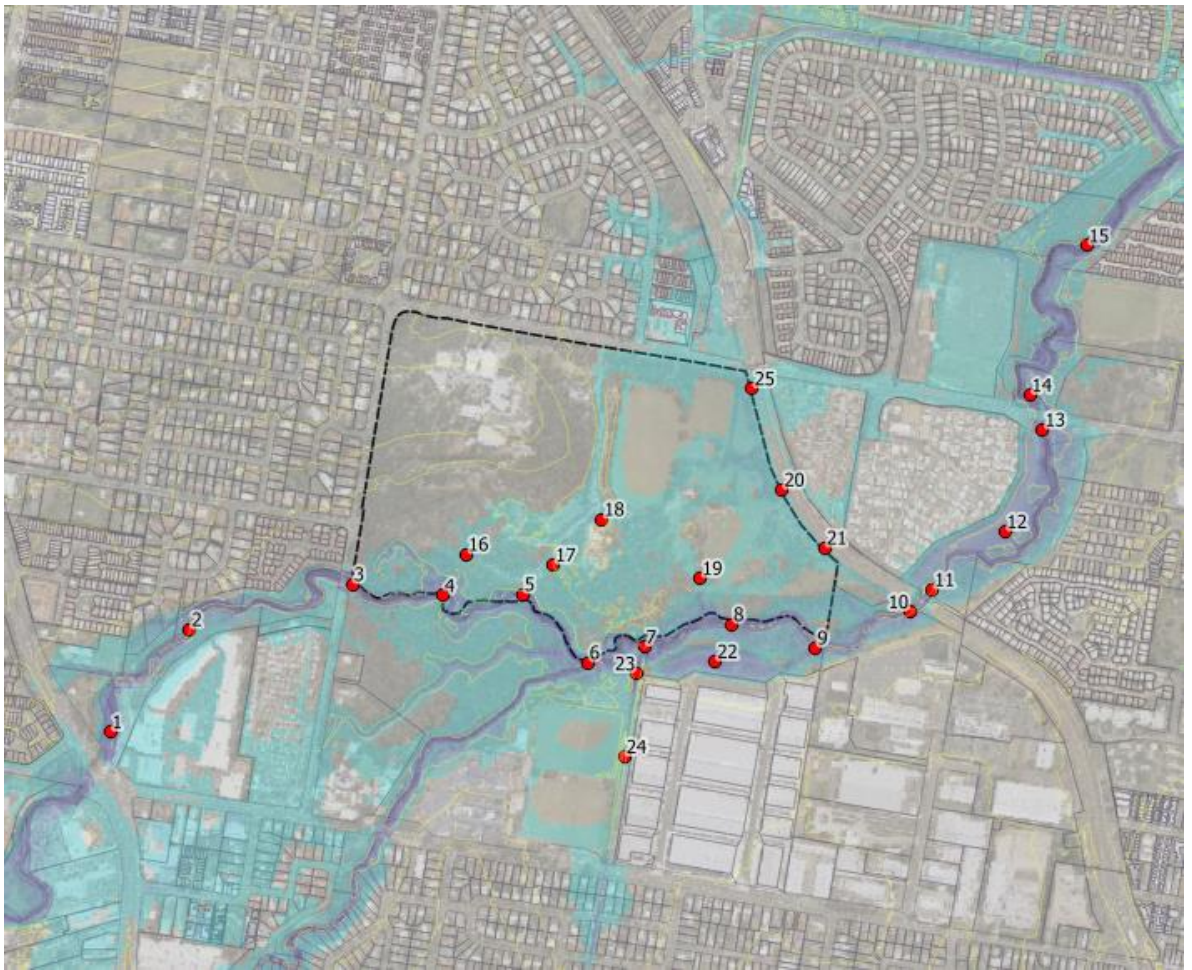

Figure 13 Reporting locations

Table 9 Peak water levels

| Water levels (mAHD) |        |        |            |        |        |            |          |         |            |        |        |            |        |        |            |        |        |            |
|---------------------|--------|--------|------------|--------|--------|------------|----------|---------|------------|--------|--------|------------|--------|--------|------------|--------|--------|------------|
| ID                  | 39%AEP |        |            | 20%AEP |        |            | 10%AEP   |         |            | 5%AEP  |        |            | 2%AEP  |        |            | 1%AEP  |        |            |
|                     | pre    | post   | difference | pre    | post   | difference | pre      | post    | difference | pre    | post   | difference | pre    | post   | difference | pre    | post   | difference |
| 1                   | 17.791 | 17.791 | 0.000      | 18.270 | 18.270 | 0.000      | 18.53221 | 18.5323 | 0.000      | 18.804 | 18.804 | 0.000      | 18.999 | 18.999 | 0.000      | 19.077 | 19.077 | 0.000      |
| 2                   | 16.866 | 16.866 | 0.000      | 17.364 | 17.364 | 0.000      | 17.638   | 17.639  | 0.000      | 17.941 | 17.942 | 0.000      | 18.169 | 18.169 | 0.000      | 18.262 | 18.262 | 0.000      |
| 3                   | 15.475 | 15.476 | 0.001      | 16.008 | 16.010 | 0.002      | 16.272   | 16.274  | 0.001      | 16.542 | 16.543 | 0.001      | 16.717 | 16.717 | 0.000      | 16.779 | 16.779 | 0.000      |
| 4                   | 15.165 | 15.167 | 0.002      | 15.693 | 15.696 | 0.003      | 15.953   | 15.955  | 0.002      | 16.217 | 16.218 | 0.001      | 16.372 | 16.373 | 0.001      | 16.428 | 16.428 | 0.000      |
| 5                   | 14.553 | 14.557 | 0.004      | 15.083 | 15.090 | 0.006      | 15.318   | 15.322  | 0.004      | 15.543 | 15.545 | 0.002      | 15.703 | 15.705 | 0.002      | 15.796 | 15.797 | 0.001      |
| 6                   | 13.739 | 13.742 | 0.003      | 14.217 | 14.222 | 0.006      | 14.462   | 14.467  | 0.005      | 14.734 | 14.739 | 0.005      | 15.044 | 15.048 | 0.004      | 15.267 | 15.270 | 0.003      |
| 7                   | 13.387 | 13.388 | 0.001      | 13.831 | 13.835 | 0.004      | 14.064   | 14.067  | 0.004      | 14.331 | 14.337 | 0.006      | 14.635 | 14.638 | 0.003      | 14.875 | 14.879 | 0.004      |
| 8                   | 12.934 | 12.932 | -0.002     | 13.306 | 13.306 | -0.001     | 13.499   | 13.498  | -0.001     | 13.715 | 13.718 | 0.004      | 13.961 | 13.964 | 0.003      | 14.191 | 14.197 | 0.007      |
| 9                   | 12.299 | 12.301 | 0.002      | 12.664 | 12.663 | -0.002     | 12.867   | 12.859  | -0.008     | 13.126 | 13.122 | -0.004     | 13.443 | 13.437 | -0.006     | 13.739 | 13.740 | 0.001      |
| 10                  | 11.684 | 11.683 | -0.002     | 12.084 | 12.086 | 0.002      | 12.338   | 12.335  | -0.002     | 12.692 | 12.695 | 0.003      | 13.098 | 13.101 | 0.003      | 13.462 | 13.470 | 0.009      |
| 11                  | 11.405 | 11.402 | -0.002     | 11.799 | 11.800 | 0.001      | 12.039   | 12.037  | -0.002     | 12.309 | 12.311 | 0.002      | 12.565 | 12.567 | 0.002      | 12.755 | 12.759 | 0.004      |
| 12                  | 11.134 | 11.131 | -0.003     | 11.573 | 11.575 | 0.001      | 11.835   | 11.834  | -0.002     | 12.120 | 12.122 | 0.002      | 12.376 | 12.378 | 0.002      | 12.561 | 12.565 | 0.004      |
| 13                  | 11.029 | 11.027 | -0.002     | 11.484 | 11.485 | 0.001      | 11.750   | 11.748  | -0.002     | 12.035 | 12.038 | 0.002      | 12.286 | 12.288 | 0.002      | 12.464 | 12.468 | 0.004      |
| 14                  | 10.955 | 10.953 | -0.002     | 11.395 | 11.396 | 0.001      | 11.643   | 11.642  | -0.002     | 11.901 | 11.903 | 0.002      | 12.118 | 12.119 | 0.002      | 12.272 | 12.275 | 0.003      |
| 15                  | 9.854  | 9.851  | -0.003     | 10.346 | 10.346 | 0.001      | 10.596   | 10.594  | -0.001     | 10.846 | 10.848 | 0.002      | 11.067 | 11.071 | 0.005      | 11.244 | 11.245 | 0.001      |
| 16                  | dry    | dry    | NA         | dry    | dry    | NA         | dry      | dry     | NA         | 16.109 | 16.109 | 0.000      | 16.240 | 16.240 | 0.001      | 16.282 | 16.282 | 0.000      |
| 17                  | dry    | dry    | NA         | dry    | dry    | NA         | dry      | dry     | NA         | 15.037 | 15.039 | 0.001      | 15.148 | 15.148 | 0.001      | 15.206 | 15.207 | 0.001      |
| 18                  | dry    | dry    | NA         | dry    | dry    | NA         | dry      | dry     | NA         | dry    | dry    | NA         | 14.824 | 14.753 | -0.071     | 14.919 | 14.849 | -0.070     |
| 19                  | dry    | dry    | NA         | dry    | dry    | NA         | dry      | dry     | NA         | dry    | dry    | NA         | dry    | dry    | NA         | 14.252 | 14.307 | 0.055      |
| 20                  | 12.810 | dry    | NA         | 12.911 | dry    | NA         | 13.037   | dry     | NA         | 13.213 | 12.865 | -0.347     | 13.426 | 13.175 | -0.251     | 13.529 | 13.481 | -0.048     |
| 21                  | 12.401 | dry    | NA         | 12.618 | 12.041 | -0.577     | 12.791   | 12.310  | -0.482     | 13.095 | 12.690 | -0.406     | 13.383 | 13.122 | -0.261     | 13.520 | 13.457 | -0.063     |
| 22                  | 11.961 | 11.964 | 0.003      | 12.720 | 12.717 | -0.003     | 12.942   | 12.934  | -0.008     | 13.254 | 13.254 | -0.001     | 13.692 | 13.692 | 0.001      | 14.024 | 14.030 | 0.007      |
| 23                  | 13.402 | 13.403 | 0.001      | 13.855 | 13.861 | 0.005      | 14.103   | 14.107  | 0.005      | 14.385 | 14.390 | 0.005      | 14.715 | 14.718 | 0.003      | 14.979 | 14.984 | 0.005      |
| 24                  | 14.969 | 14.969 | 0.000      | 15.222 | 15.228 | 0.006      | 15.275   | 15.285  | 0.010      | 15.318 | 15.313 | -0.005     | 15.357 | 15.358 | 0.000      | 15.403 | 15.403 | 0.000      |
| 25                  | 12.860 | dry    | NA         | 13.061 | dry    | NA         | 13.118   | 12.992  | -0.126     | 13.247 | 13.234 | -0.013     | 13.442 | 13.401 | -0.040     | 13.518 | 13.467 | -0.051     |



### 5.3.1 Peak flows

Peak flows upstream at the Railway Bridge over the range of storm events up to the 1% AEP (100yr ARI) are effectively retained at predeveloped levels (+0.3% to -0.2%). For the 1% AEP a minor increase is observed and represents a 0.3% increase. No adverse impacts downstream of the Bridge are observed in all events tested.

### 5.3.2 Flood inundation – existing case

Existing case flood inundation maps indicate flooding of low-lying areas at the north eastern corner of the site occurs on a frequent basis. Existing drainage within the site directs this more frequent drainage to the existing drainage outfalls to Cabbage Tree Creek. No flooding of Beams Rd is expected for the more frequent flood events. Figure 14 shows inundation mapping for the minor 39% AEP (2 yr) event.

At the 5% AEP (20 yr ARI event - see Figure 15) breakout from Cabbage Tree Creek occurs along the northern bank at the western end of the site. These breakout flows are then predicted to flow generally in a north-east direction at shallow depths through the site. Inundation in the north-east of the site is constrained west of the rail corridor. Shallow flooding of Beams Road is expected in this case and is anticipated to extend north of Beams Road.

In the 1% AEP event (refer to Figure 16) there is a significant increase in the inundation area of breakout flows through the site. While there is a large increase in the inundation extent, the actual flood depths predicted over most of this area remain typically less than 250mm. Inundation is also predicted to occur across the rail corridor at the north eastern boundary of the site and extends along Beams Road and adjacent existing developed areas to the north and east. Flow depths are noted to be mostly less than 250mm in this case, except for low lying areas adjacent to the rail corridor.

Flooding across the site resulting from Cabbage Tree Creek breakout flows is characterised by shallow (typically less than 250mm), conveyance dominated flows. Consequently, flood storage influences are expected to be minor. For this reason, it would be expected that a loss of floodplain storage in these areas would be unlikely to cause significant adverse flood impacts. This is discussed in the following sections.

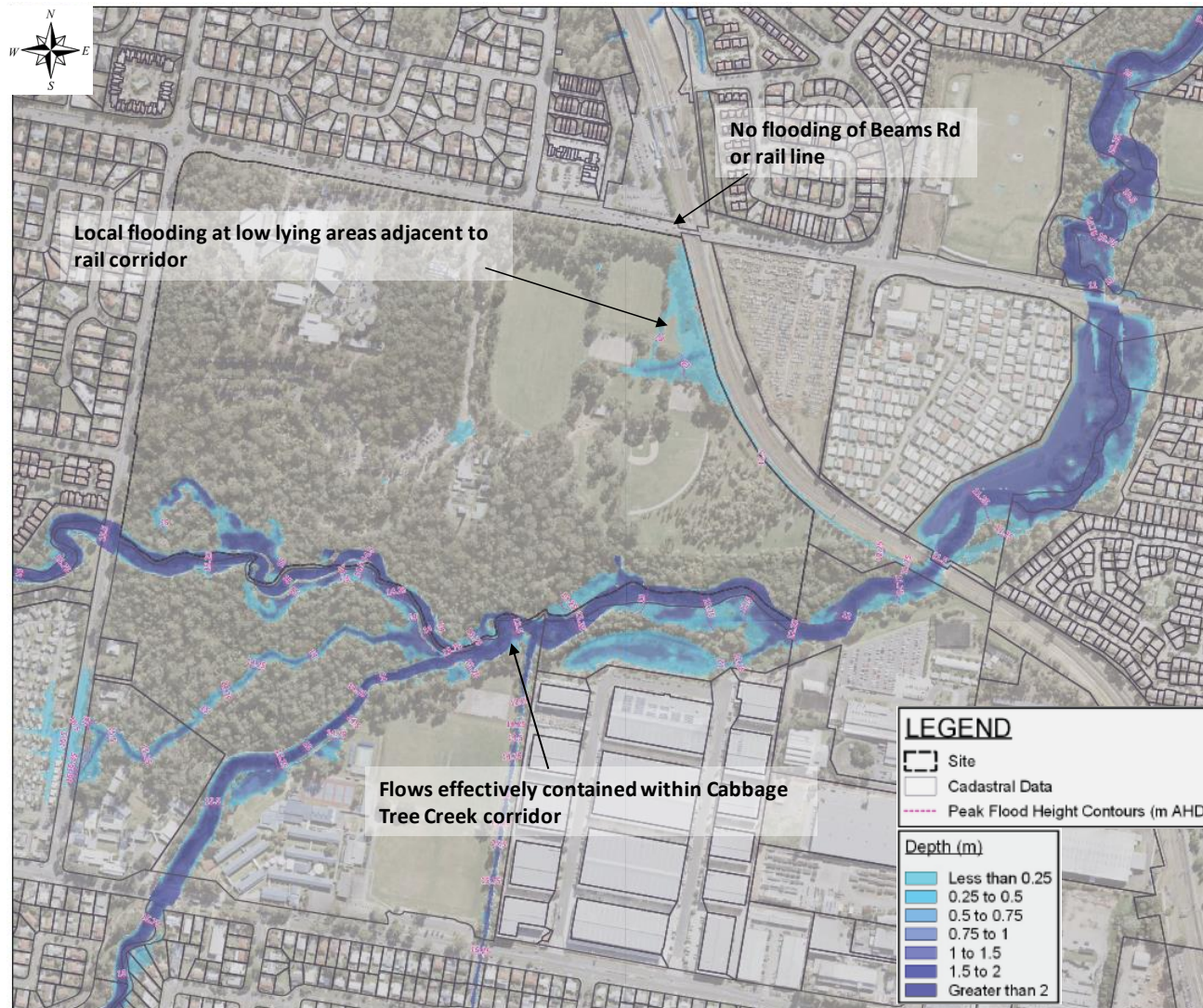

Figure 14 39% AEP flood inundation - existing conditions

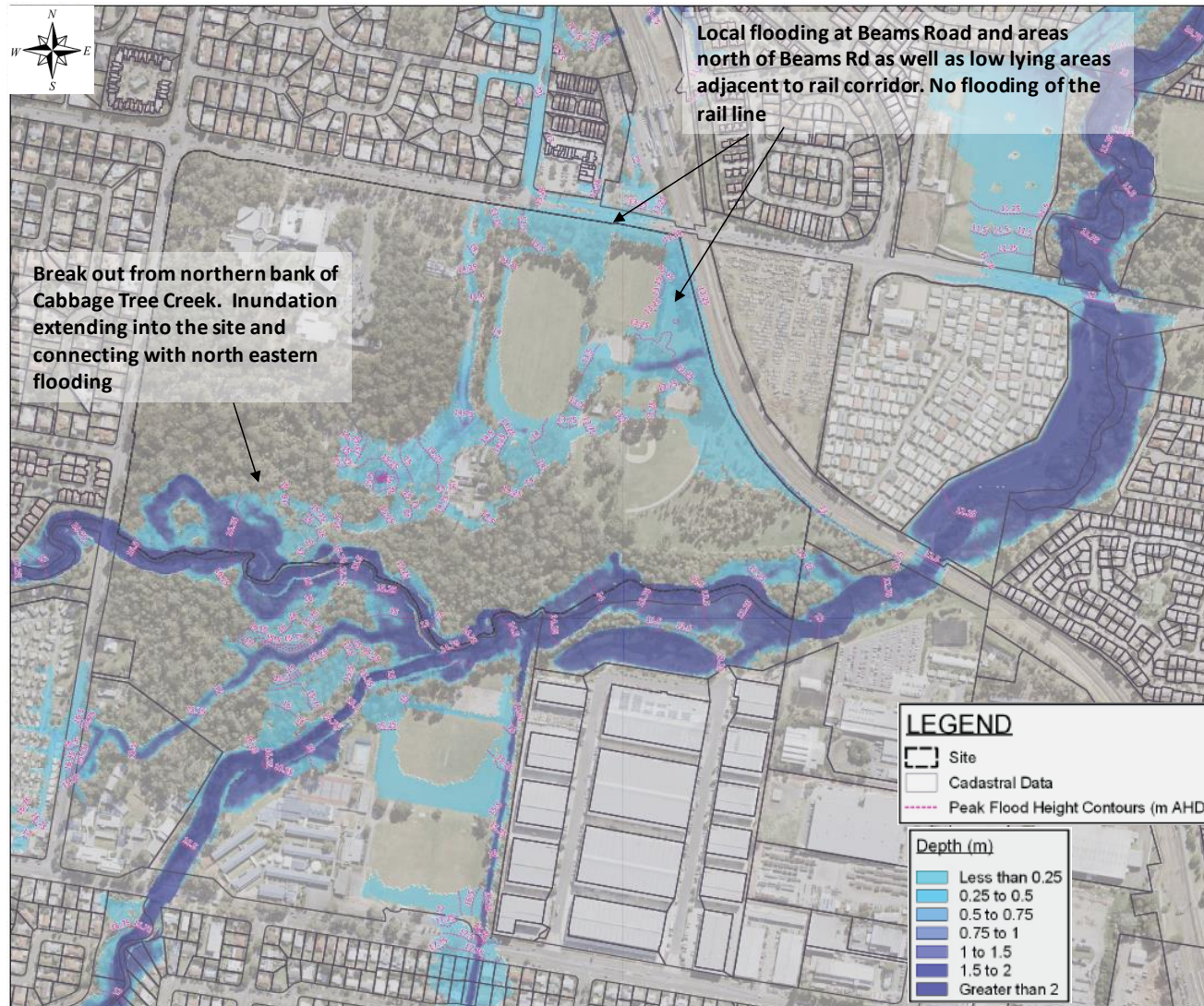

Figure 15 5% AEP flood inundation - existing conditions

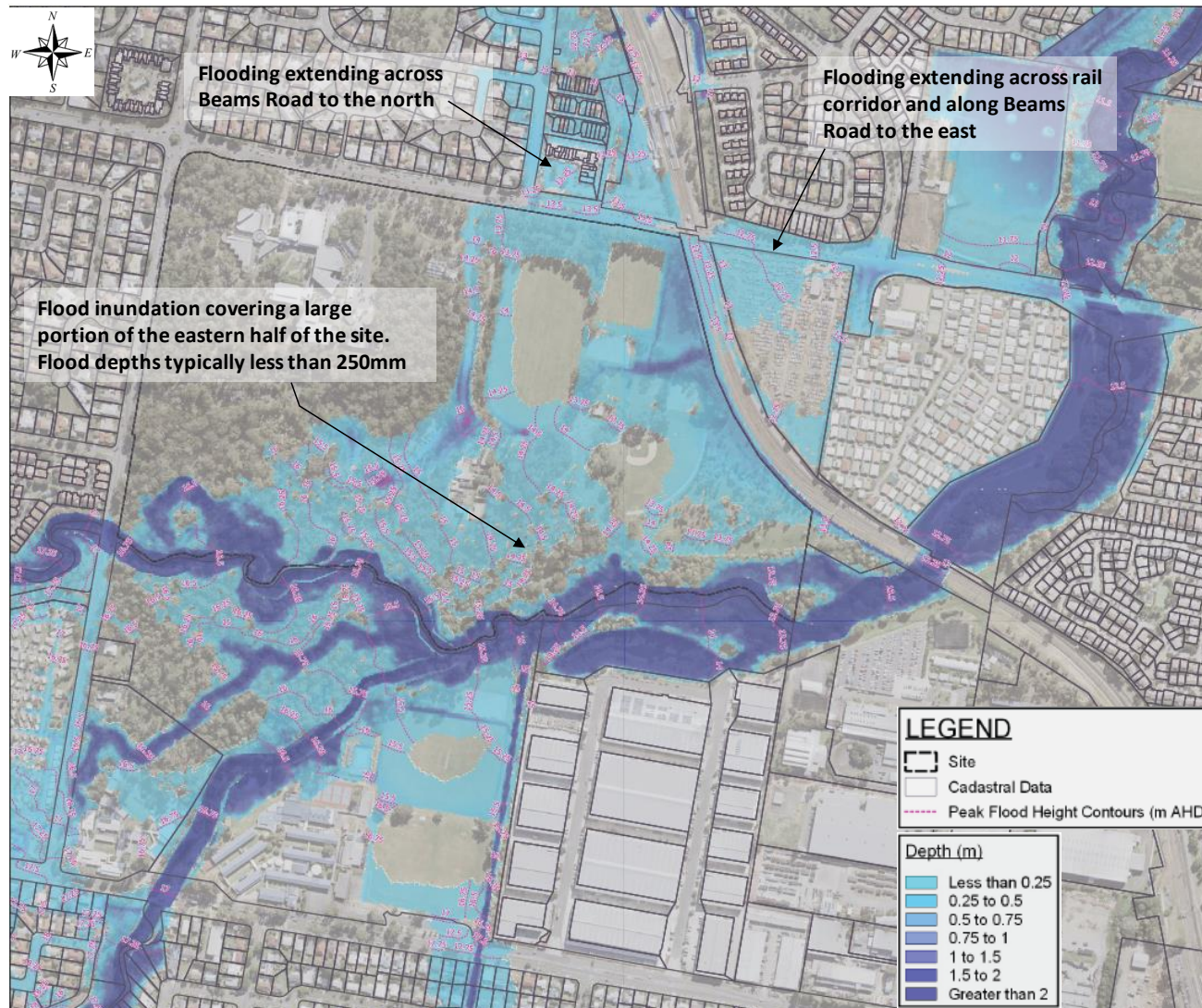

Figure 16 1% AEP flood inundation - existing conditions

### 5.3.3 Flood impacts

Table 9 previously summarises peak water levels for pre and post conditions at various reporting locations for the 39% AEP to 1% AEP model runs. Flood impacts maps for the 39% AEP to 1% AEP are included in Appendix A.

Flood impact maps demonstrate no significant adverse impacts occurring external to the site as a result of the development, with the proposed mitigation measures included.

Improved flood conditions are observed at Beams Road and the rail line at the north-east corner of the site. This is because much of the site drainage is directed to Cabbage Tree Creek as part of the development. Furthermore, during larger magnitude events, the proposed development filling restricts Cabbage Tree Creek breakout flow from entering this area.

Impacts noted on the afflux maps are typically contained within the site boundary and are associated with flooding of the sports fields (above 5% AEP event) and the operation of the development drainage swales. This is expected. Other low-lying riparian bushland areas already subject to flooding within the site also experience localised increases in flooding south west of the sports fields, however this does not impact on any existing facilities or infrastructure. Increases in flooding within the site as described above help offset loss of flood storage. Commercial and residential lots are protected from flooding during the 1% AEP (100 year ARI) event.

Minor impacts (typically up to 50mm) external to the site at the south eastern boundary are noted, however these occur in a low-lying bushland area currently subject to flooding from Cabbage Tree Creek and is not considered an actionable nuisance.

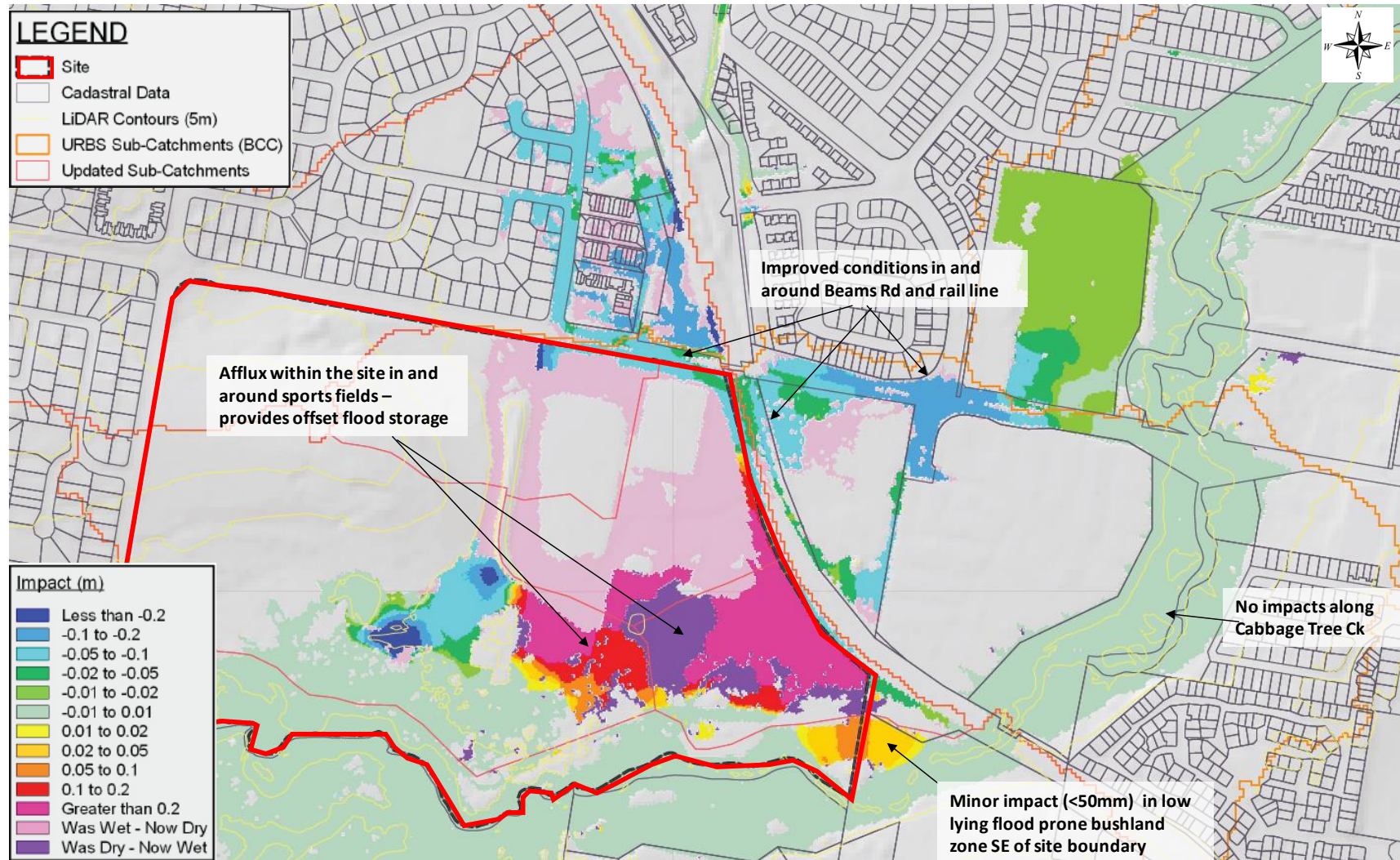

Figure 17 1% AEP flood impacts

### 5.3.4 Flood storage

An assessment of the impacts of development on flood storage has been completed for the 1% AEP event. This is to review compensatory earthworks, in line with BCC compensatory earthworks planning scheme policy for developments within mapped creek corridors.

Flood storage volumes within the site boundary have been calculated for the existing case and developed case scenarios. Table 10 summarises the estimated flood storage volumes, based on the current model assumptions.

**Table 10 Flood storage volumes – 1% AEP**

| Scenario            | Flood storage (m <sup>3</sup> ) |
|---------------------|---------------------------------|
| Existing conditions | 44,929                          |
| Developed case      | 38,208                          |
| Loss in storage     | 6,721                           |

Overall, the flood modelling predicts that a loss of flood storage will occur (~15%). Despite this, the modelling also demonstrates that no significant adverse offsite flood impacts are expected to occur along Cabbage Tree Creek and improved flood conditions can be expected at both Beams Road and the rail line at the north east of the site. This is because the storage loss is relatively minor in the context of the regional floodplain and the site largely serves a flood conveyance (or overland flow) function as opposed to a flood storage function for Cabbage Tree Creek floodwaters.

## 6 MAINTENANCE

---

WSUD infrastructure such as bioretention basins require ongoing inspection and maintenance to ensure they establish and operate in accordance with the design intent. Potential problems associated with WSUD as a result of poor maintenance include:

- Decreased aesthetic amenity;
- Reduced functional performance;
- Public health and safety risks; and
- Decreased habitat diversity (dominance of exotic weeds).

### 6.1 MAINTENANCE PLAN

A Maintenance Plan will be required prior to handover of WSUD assets. The plan will provide detailed guidance around maintenance of WSUD assets, as well as frequency of maintenance activities. The manual will include performance inspection checklists. The document will be consistent with the methodologies and principles detailed in *Maintaining WSUD Assets (Water by Design, 2012)*.

The maintenance plan and checklists will be a living document and can be refined where required in collaboration with Council assets and maintenance departments to ensure the structure and frequency of maintenance is consistent with current Council procedures. This will also provide an opportunity for transfer of knowledge in this regard to allow Council to effectively operate the sediment ponds and bioretention basin.

#### 6.1.1 Bioretention basins

Typical maintenance of bioretention systems during operation will involve:

- Routine inspection of the bio-retention system profile to identify any areas of obvious increased sediment deposition, scouring from storm flows, rill erosion of the batters from lateral inflows, damage to the profile from vehicles and clogging of the bio-retention system (evident by a 'boggy' filter media surface).
- Routine inspection of inflows systems, overflow pits and under-drains to identify and clean any areas of scour, litter build up and blockages.
- Removal of sediment where it is smothering the bio-retention system vegetation.
- Repairing any damage to the profile resulting from scour, rill erosion or vehicle damage by replacement of appropriate fill (to match onsite soils) and revegetating.
- Tilling of the bioretention system surface, or removal of the surface layer, if there is evidence of clogging.
- Regular watering/ irrigation of vegetation until plants are established and actively growing.
- Removal and management of invasive weeds (herbicides should not be used).



- Removal of plants that have died and replacement with plants of equivalent size and species as detailed in the plant schedule.
- Pruning to remove dead or diseased vegetation material and to stimulate growth.
- Vegetation pest monitoring and control.

Maintenance should only occur after a reasonably rain free period when the soil in the bioretention system is dry. Inspections are also recommended following large storm events to check for scour and other damage.

## 7 CONCLUSION

---

An updated stormwater management strategy has been developed for the Carseldine Urban Village to meet the requirements of the *State Planning Policy* (DLGIP, 2017), QUDM and *Brisbane City Council Planning Scheme*.

### STORMWATER TREATMENT

The updated strategy includes two (2) bioretention basins that treat development runoff prior to discharge to Cabbage Tree Creek:

- Bioretention Basin B1 265m<sup>2</sup> filter area treating Stages 2, 3 (part of) and S
- Bioretention Basin B2 500m<sup>2</sup> filter area total treating the remainder of the development (Stages 1,3 (part of), 4 and 5)

Drainage swales along the eastern boundary of the site and at the southern boundary of the Stage S sports fields also provide additional treatment.

### FLOODING

Flood impact assessment demonstrates no significant impacts occurring external to the site as a result of development. Some afflux (~50mm) is observed immediately south east of the development boundary, however this afflux occurs within a low-lying flood prone bushland area and is not considered an actionable nuisance.

Improved flood conditions are observed at Beams Road and the rail line at the north-east end of the site. This is because much of the site drainage will be directed to Cabbage Tree Creek. Furthermore, during larger magnitude events, the proposed development fill restricts Cabbage Tree Creek breakout flow from entering this area.

Required mitigation measures to manage flood impacts external to the site include:

- Providing flood storage over the sports field zone for events greater than the 5% AEP (20 year ARI)
- incorporation of a 1200mm dia pipe with one-way flap valve along the new drainage swale draining the eastern half of the development – this minimizes the impacts of Cabbage Tree Creek flows into the site via this new connection to Cabbage Tree Creek
- inclusion of a flood barrier along the eastern boundary of the site (~1m high) – this avoids increases in flood levels external to the site adjacent to the rail line

Updated regional modelling and detailed local modelling will occur as part of continuing design development for the site.

## 8 REFERENCES

---

Australian Rainfall and Runoff (1987). *A Guide to Flood Estimation*. Engineers Australia

Calibre (2017). *Flood Impact Assessment & Concept Stormwater Management Plan – Carseldine Urban Village (Master Plan)*. Prepared for Economic Development Queensland.

DLGIP (2017). *State Planning Policy*

Healthy Waterways (2010). *MUSIC Modelling Guidelines*

QUDM (2007). *Queensland Urban Drainage Manual*. Second Edition 2007. Department of Natural Resources and Water

SGS (2017). *Geotechnical Investigation Report – Carseldine Urban Village, Beams Road, Carseldine*. Prepared for Economic Development Queensland.

## APPENDIX A – TUFLOW MODEL OUTPUTS

---

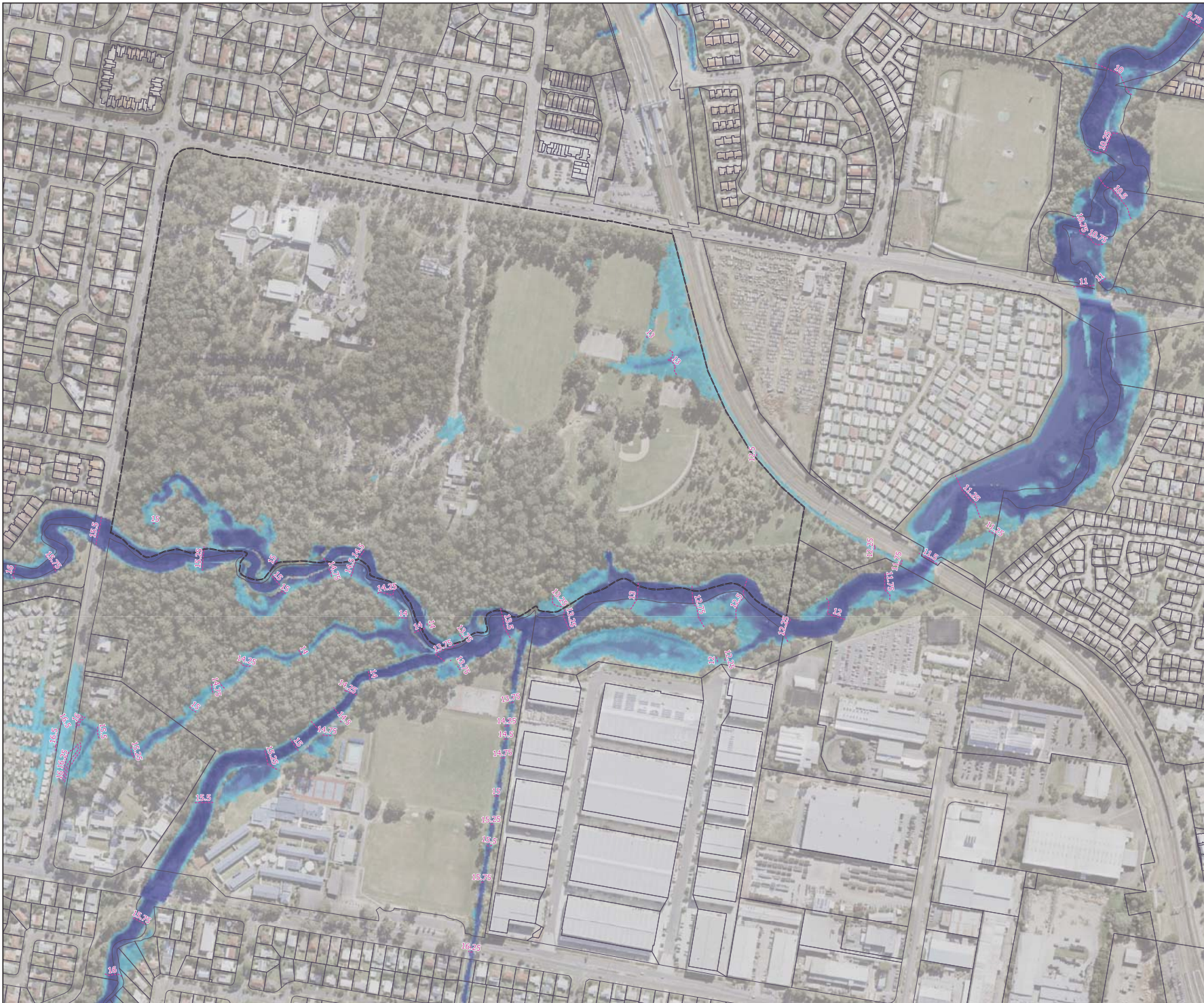

**LEGEND**

- Site
- Cadastral Data
- Peak Flood Height Contours (m AHD)

**Depth (m)**

- Less than 0.25
- 0.25 to 0.5
- 0.5 to 0.75
- 0.75 to 1
- 1 to 1.5
- 1.5 to 2
- Greater than 2

**FIGURE A1**

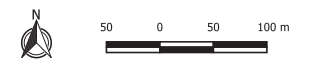

© Hydrology and Water Management Consulting Pty Ltd (HWMC) 2019.  
HWMC endeavours to ensure that the information contained in this figure is correct at the time of publication. Furthermore, HWMC makes no representations, warranties or guarantees about its accuracy.

**Carseldine Urban Village**

**Peak Flood Depth & Peak Flood Level Contours**

**Existing Case (TUFLOW ID B01d)**







**39% AEP Event (Q002)**

Client: Economic Development Queensland

**LEGEND**

-  Site
-  Cadastral Data
-  Peak Flood Height Contours (m AHD)

**Depth (m)**

-  Less than 0.25
-  0.25 to 0.5
-  0.5 to 0.75
-  0.75 to 1
-  1 to 1.5
-  1.5 to 2
-  Greater than 2

**FIGURE A2**



© Hydrology and Water Management Consulting Pty Ltd (HWMC) 2019.  
HWMC endeavours to ensure that the information contained in this figure is correct at the time of publication. Furthermore, HWMC makes no representations, warranties or guarantees about its accuracy.

**Carseldine Urban Village**

**Peak Flood Depth & Peak Flood Level Contours**

**Existing Case  
(TUFLOW ID B01d)**

**5% AEP Event (Q020)**



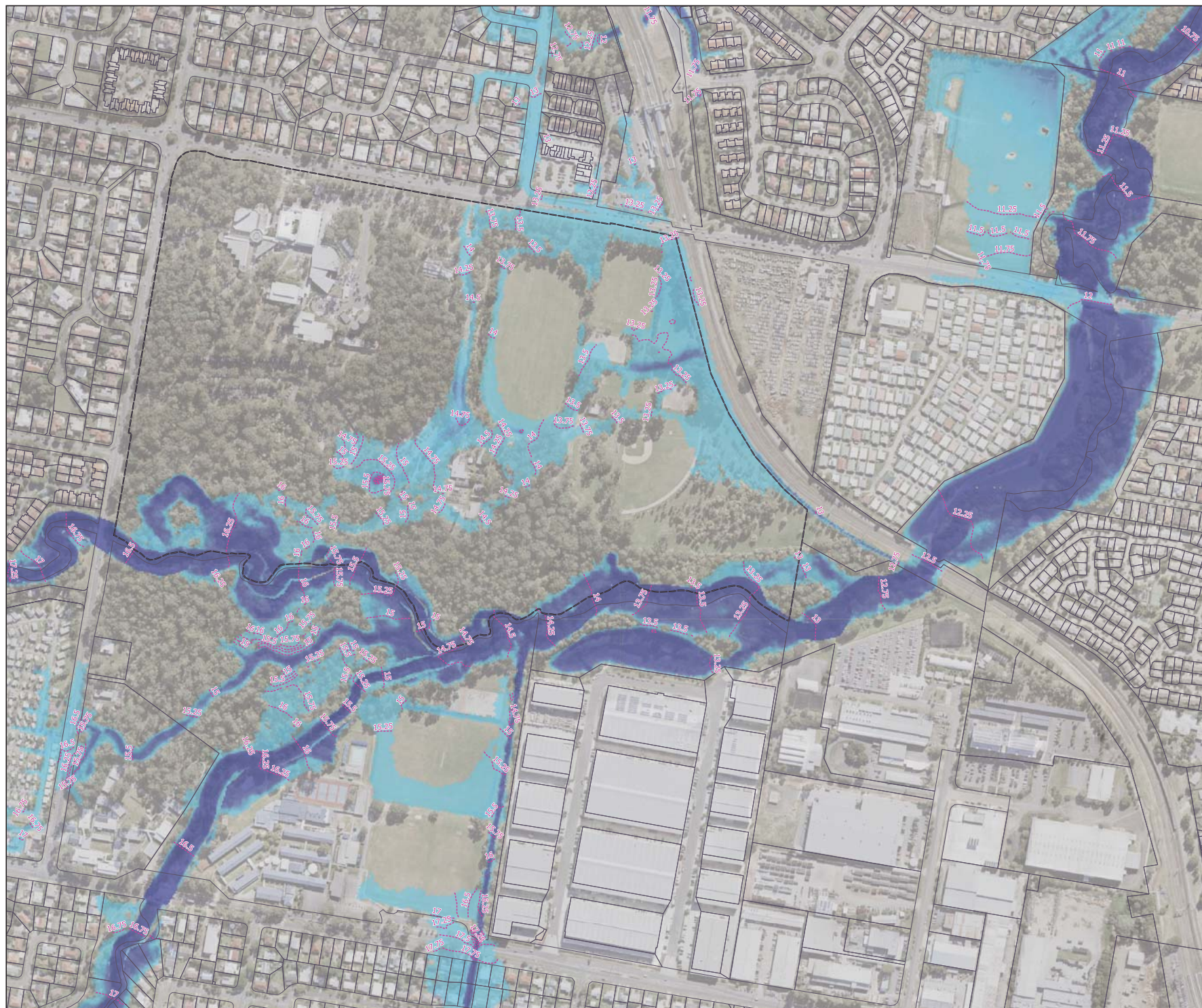



Client: Economic Development Queensland



**LEGEND**

-  Site
-  Cadastral Data
-  Peak Flood Height Contours (m AHD)

**Depth (m)**

-  Less than 0.25
-  0.25 to 0.5
-  0.5 to 0.75
-  0.75 to 1
-  1 to 1.5
-  1.5 to 2
-  Greater than 2

**FIGURE A3**



© Hydrology and Water Management Consulting Pty Ltd (HWMC) 2019.  
HWMC endeavours to ensure that the information contained in this figure is correct at the time of publication. Furthermore, HWMC makes no representations, warranties or guarantees about its accuracy.

**Carseldine Urban Village**

**Peak Flood Depth & Peak Flood Level Contours**



**Existing Case  
(TUFLOW ID B01d)**

**1% AEP Event (Q100)**

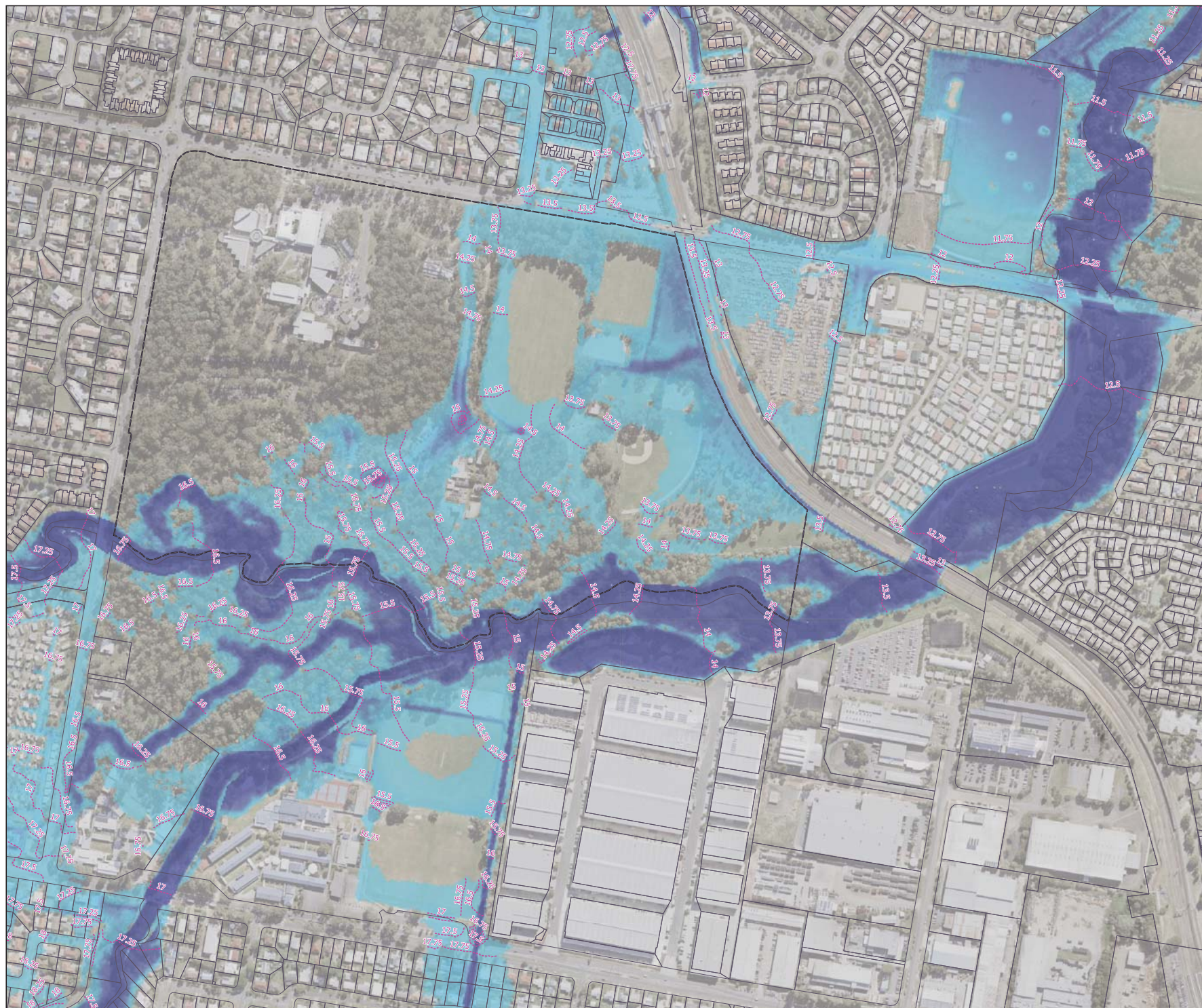





Client: Economic Development Queensland



**LEGEND**

-  Site
-  Cadastral Data
-  Peak Flood Height Contours (m AHD)

**Depth (m)**

-  Less than 0.25
-  0.25 to 0.5
-  0.5 to 0.75
-  0.75 to 1
-  1 to 1.5
-  1.5 to 2
-  Greater than 2

**FIGURE A4**



© Hydrology and Water Management Consulting Pty Ltd (HWMC) 2019.  
HWMC endeavours to ensure that the information contained in this figure is correct at the time of publication. Furthermore, HWMC makes no representations, warranties or guarantees about its accuracy.

**Carseldine Urban Village**

**Peak Flood Depth & Peak Flood Level Contours**

**Proposed Case  
(TUFLOW ID P02)**

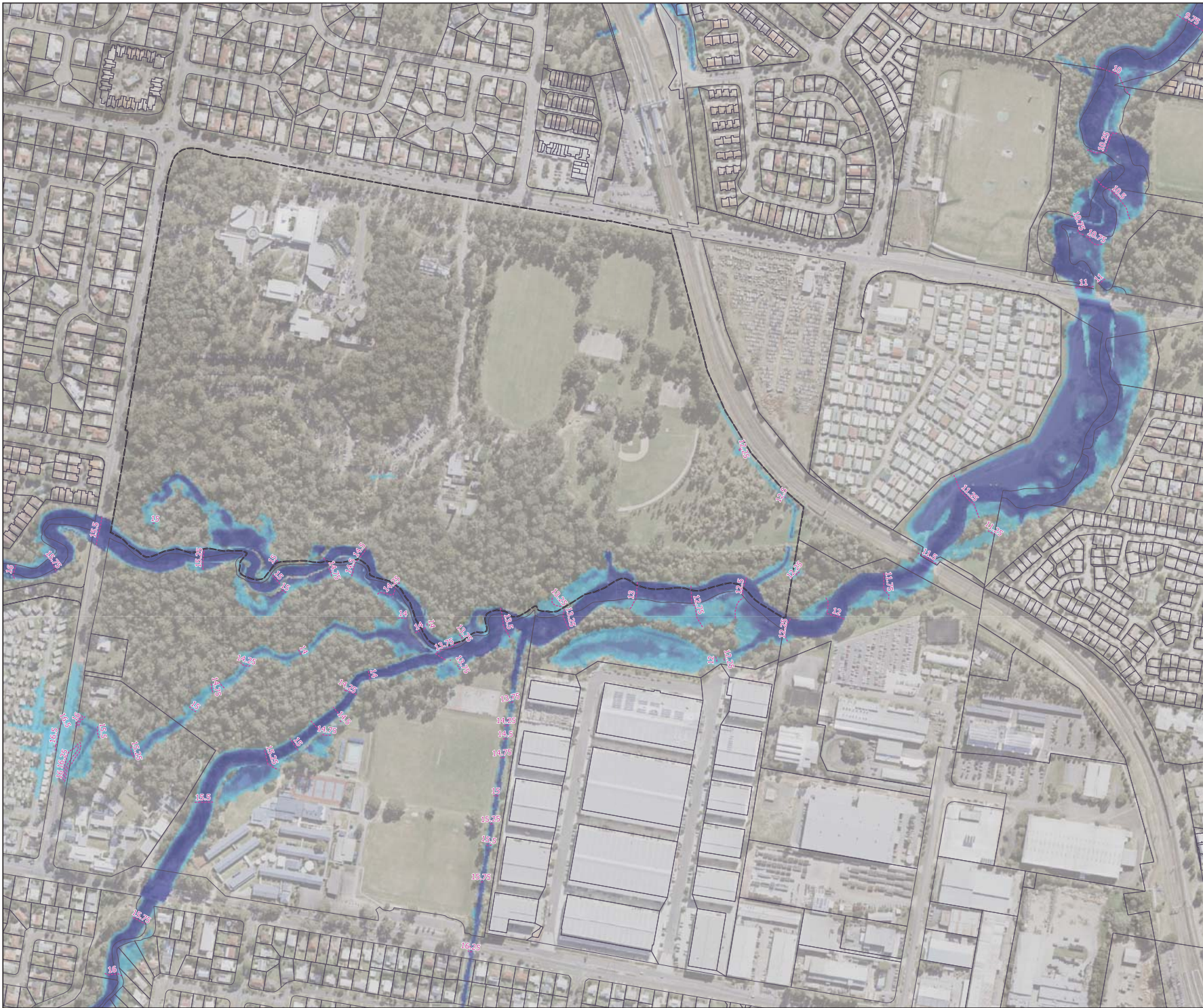

**39% AEP Event (Q2)**

Client: Economic Development Queensland











**LEGEND**

-  Site
-  Cadastral Data
-  Peak Flood Height Contours (m AHD)

**Depth (m)**

-  Less than 0.25
-  0.25 to 0.5
-  0.5 to 0.75
-  0.75 to 1
-  1 to 1.5
-  1.5 to 2
-  Greater than 2

**FIGURE A5**



© Hydrology and Water Management Consulting Pty Ltd (HWMC) 2019.  
HWMC endeavours to ensure that the information contained in this figure is correct at the time of publication. Furthermore, HWMC makes no representations, warranties or guarantees about its accuracy.

**Carseldine Urban Village**

**Peak Flood Depth & Peak Flood Level Contours**

**Proposed Case  
(TUFLOW ID P02)**

**5% AEP Event (Q20)**



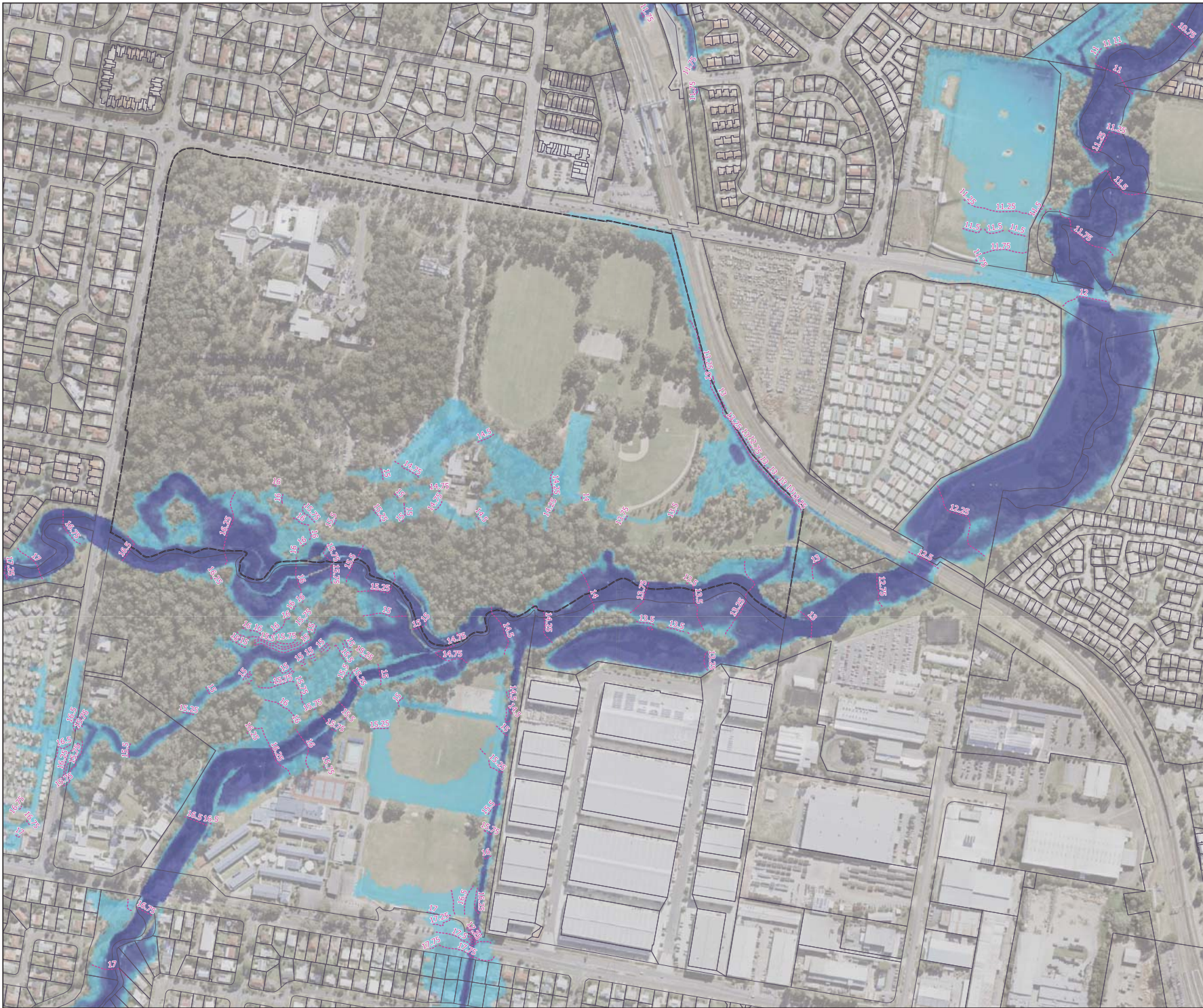



Client: Economic Development Queensland



**LEGEND**

-  Site
-  Cadastral Data
-  Peak Flood Height Contours (m AHD)

**Depth (m)**

-  Less than 0.25
-  0.25 to 0.5
-  0.5 to 0.75
-  0.75 to 1
-  1 to 1.5
-  1.5 to 2
-  Greater than 2

**FIGURE A6**



© Hydrology and Water Management Consulting Pty Ltd (HWMC) 2019.  
HWMC endeavours to ensure that the information contained in this figure is correct at the time of publication. Furthermore, HWMC makes no representations, warranties or guarantees about its accuracy.

**Carseldine Urban Village**

**Peak Flood Depth & Peak Flood Level Contours**

**Proposed Case  
(TUFLOW ID P02J)**

**1% AEP Event (Q100)**

Client: Economic Development Queensland

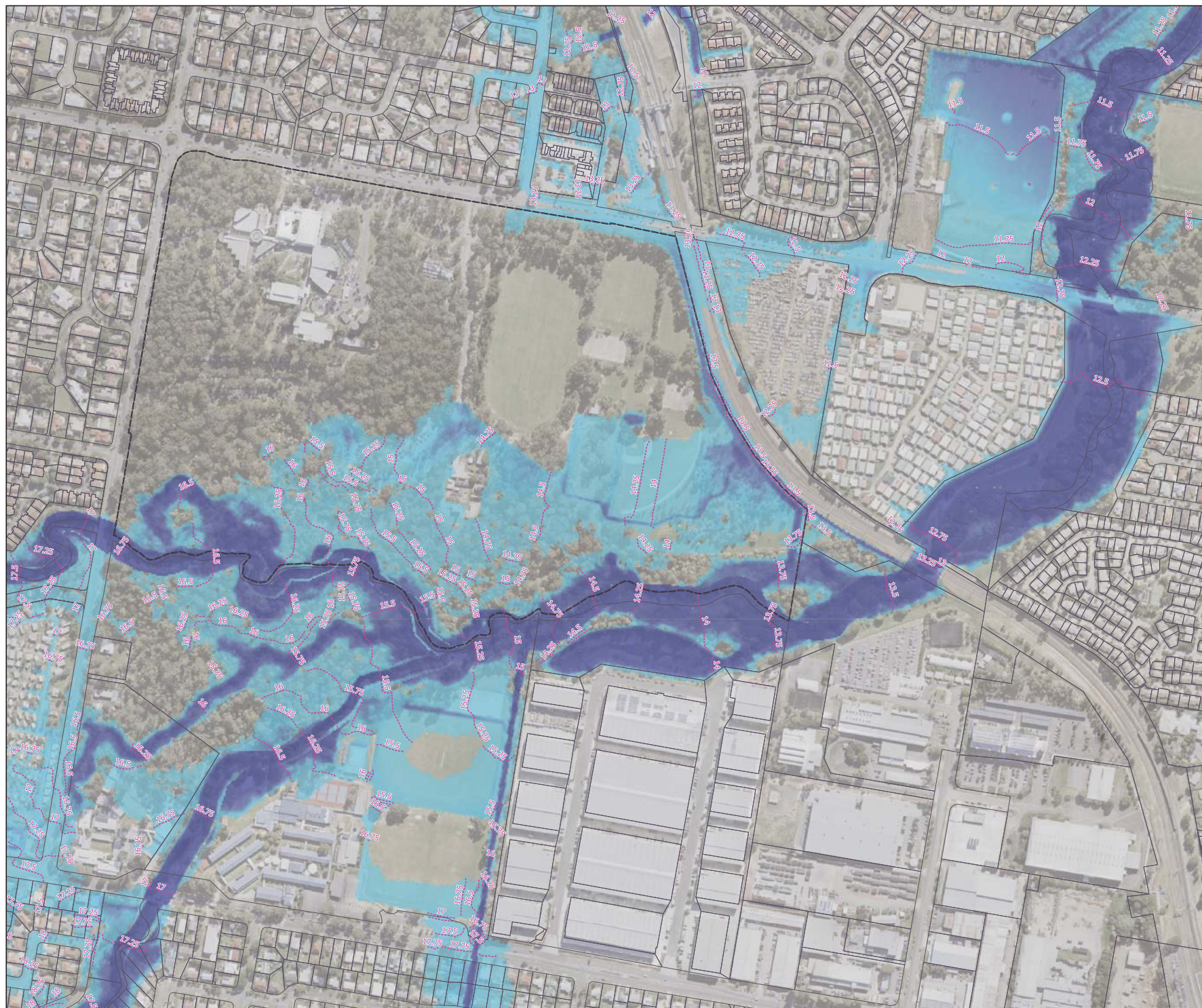

**LEGEND**

- Site
- Cadastral Data
- LiDAR Contours (5m)
- URBS Sub-Catchments (BCC)
- Updated Sub-Catchments

**Impact (m)**

- Less than -0.2
- 0.1 to -0.2
- 0.05 to -0.1
- 0.02 to -0.05
- 0.01 to -0.02
- 0.01 to 0.01
- 0.01 to 0.02
- 0.02 to 0.05
- 0.05 to 0.1
- 0.1 to 0.2
- Greater than 0.2
- Was Wet - Now Dry
- Was Dry - Now Wet

**FIGURE A7**

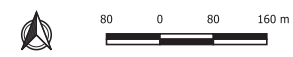

© Hydrology and Water Management Consulting Pty Ltd (HWMC) 2019.  
HWMC endeavours to ensure that the information contained in this figure is correct at the time of publication. Furthermore, HWMC makes no representations, warranties or guarantees about its accuracy.

**Carseldine Urban Village**

**Peak Flood Level Impacts  
Proposed Vs Existing Case**

**(TUFLOW Case P02j Vs B01d)**

**39%AEP Event (Q002)**

Client: Economic Development Queensland

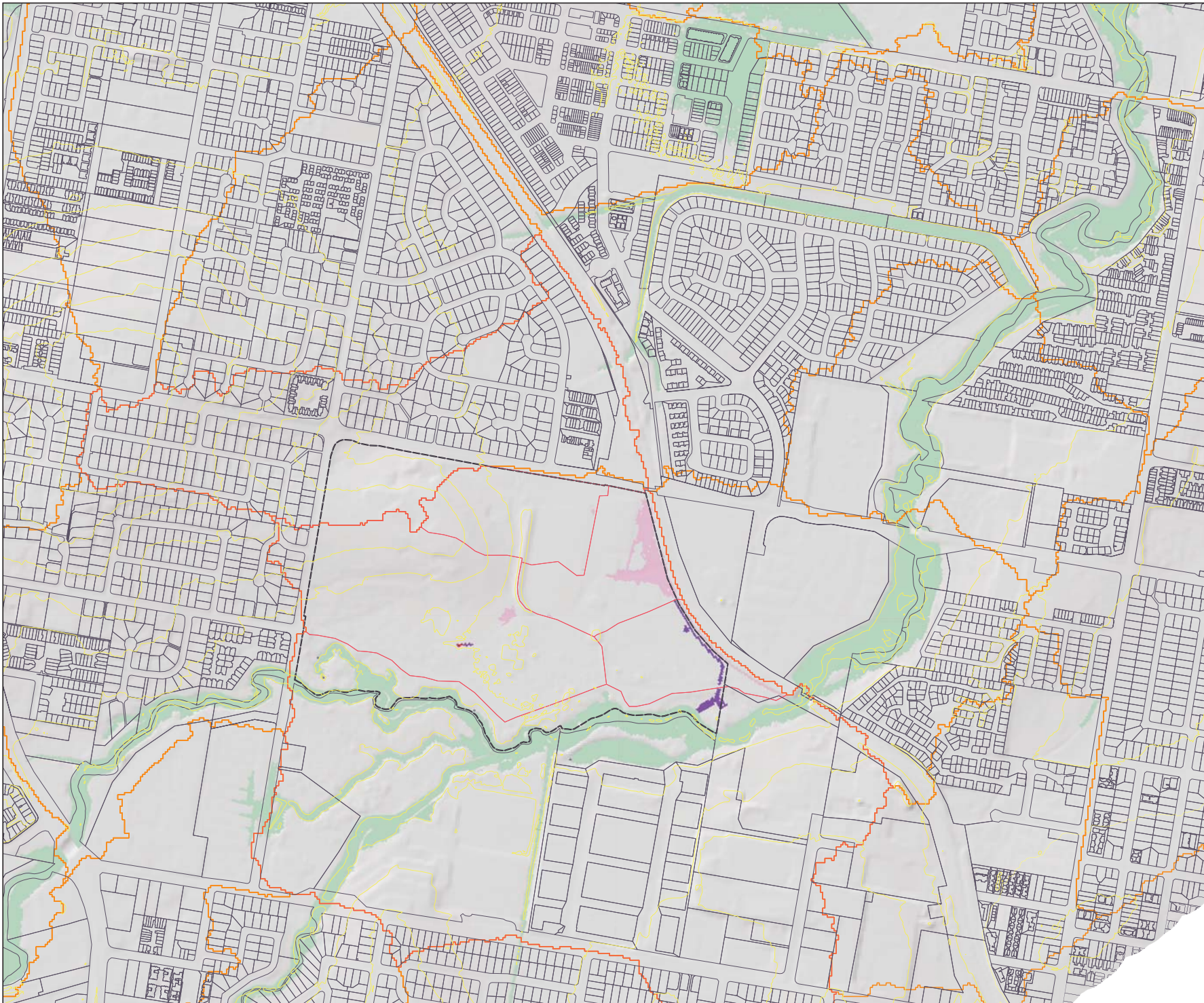

**LEGEND**

- Site
- Cadastral Data
- LiDAR Contours (5m)
- URBS Sub-Catchments (BCC)
- Updated Sub-Catchments

**Impact (m)**

- Less than -0.2
- 0.1 to -0.2
- 0.05 to -0.1
- 0.02 to -0.05
- 0.01 to -0.02
- 0.01 to 0.01
- 0.01 to 0.02
- 0.02 to 0.05
- 0.05 to 0.1
- 0.1 to 0.2
- Greater than 0.2
- Was Wet - Now Dry
- Was Dry - Now Wet

**FIGURE A8**

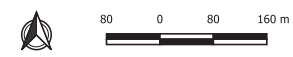

© Hydrology and Water Management Consulting Pty Ltd (HWMC) 2019.  
HWMC endeavours to ensure that the information contained in this figure is correct at the time of publication. Furthermore, HWMC makes no representations, warranties or guarantees about its accuracy.

**Carseldine Urban Village**

**Peak Flood Level Impacts  
Proposed Vs Existing Case**

**(TUFLOW Case P02j Vs B01d)**

**20% AEP Event (Q5)**

Client: Economic Development Queensland

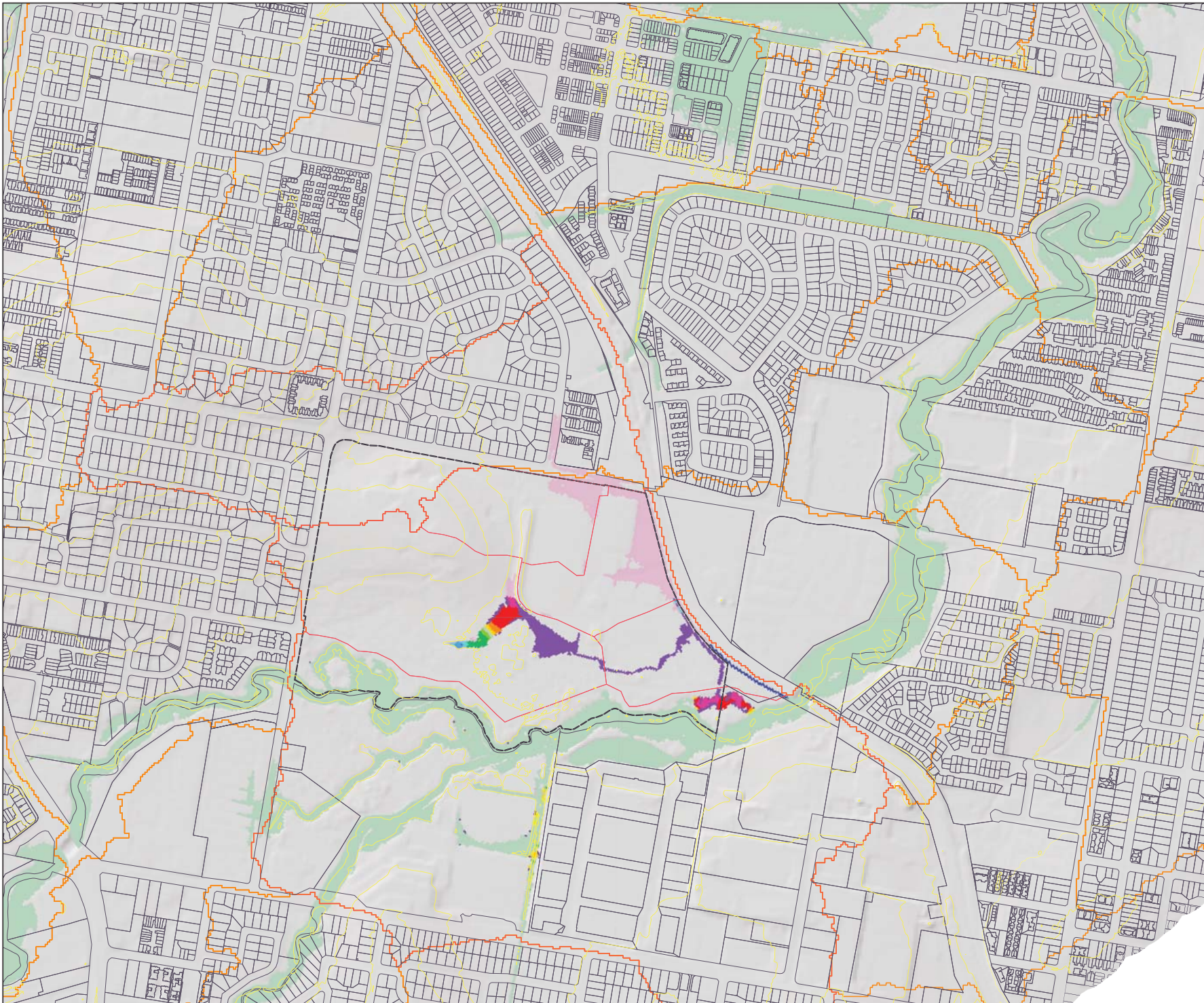

**LEGEND**

- Site
- Cadastral Data
- LiDAR Contours (5m)
- URBS Sub-Catchments (BCC)
- Updated Sub-Catchments

**Impact (m)**

- Less than -0.2
- 0.1 to -0.2
- 0.05 to -0.1
- 0.02 to -0.05
- 0.01 to -0.02
- 0.01 to 0.01
- 0.01 to 0.02
- 0.02 to 0.05
- 0.05 to 0.1
- 0.1 to 0.2
- Greater than 0.2
- Was Wet - Now Dry
- Was Dry - Now Wet

**FIGURE A9**

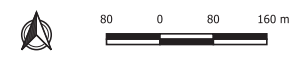

© Hydrology and Water Management Consulting Pty Ltd (HWMC) 2019.  
HWMC endeavours to ensure that the information contained in this figure is correct at the time of publication. Furthermore, HWMC makes no representations, warranties or guarantees about its accuracy.

**Carseldine Urban Village**

**Peak Flood Level Impacts  
Proposed Vs Existing Case**

**(TUFLOW Case P02j Vs B01d)**

**10% AEP Event (Q10)**

Client: Economic Development Queensland

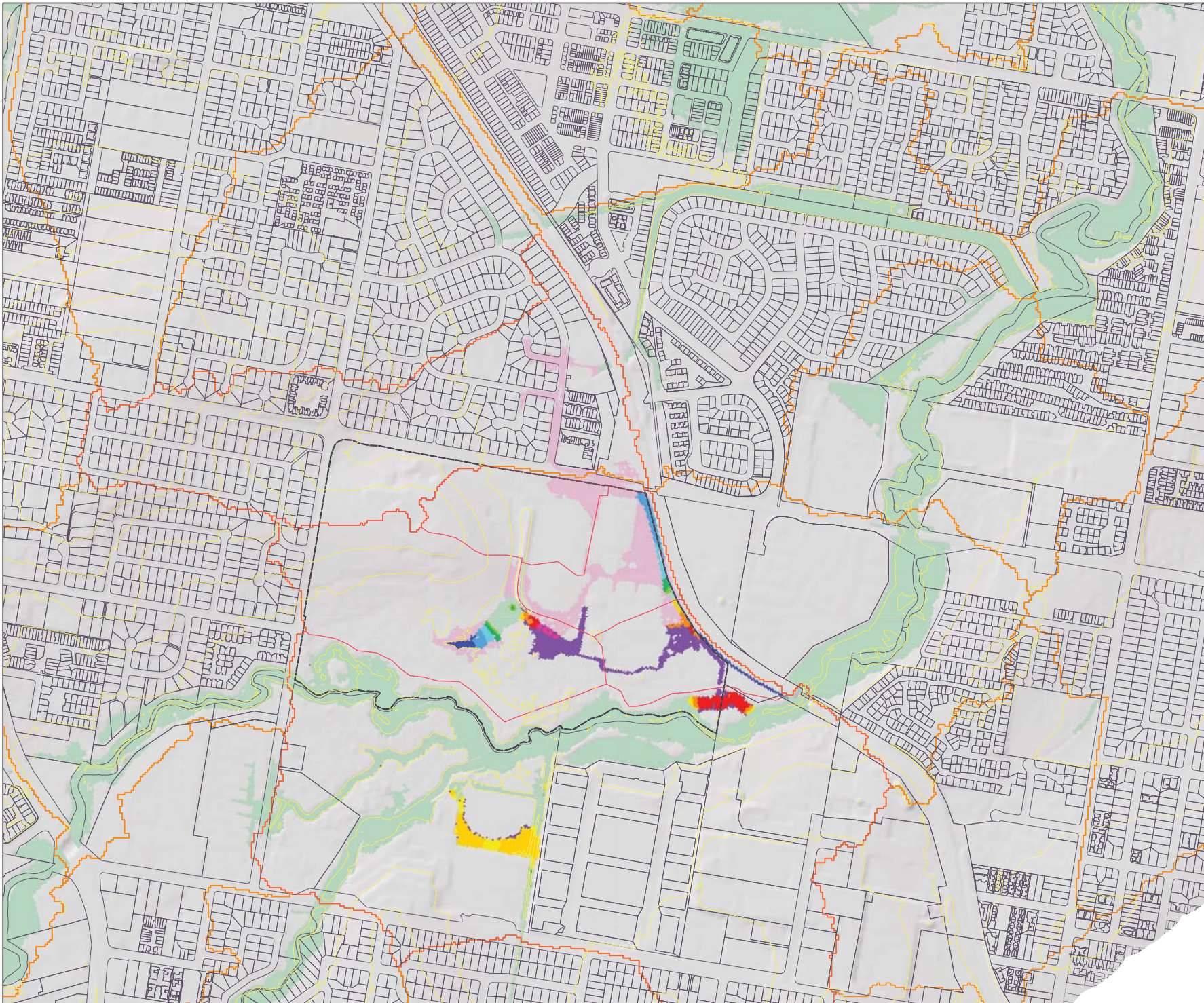

**LEGEND**

- Site
- Cadastral Data
- LiDAR Contours (5m)
- URBS Sub-Catchments (BCC)
- Updated Sub-Catchments

**Impact (m)**

- Less than -0.2
- 0.1 to -0.2
- 0.05 to -0.1
- 0.02 to -0.05
- 0.01 to -0.02
- 0.01 to 0.01
- 0.01 to 0.02
- 0.02 to 0.05
- 0.05 to 0.1
- 0.1 to 0.2
- Greater than 0.2
- Was Wet - Now Dry
- Was Dry - Now Wet

**FIGURE A10**



© Hydrology and Water Management Consulting Pty Ltd (HWMC) 2018.  
HWMC endeavours to ensure that the information contained in this figure is correct at the time of publication. Furthermore, HWMC makes no representations, warranties or guarantees about its accuracy.

**Carseldine Urban Village**

**Peak Flood Level Impacts  
Proposed Vs Existing Case**



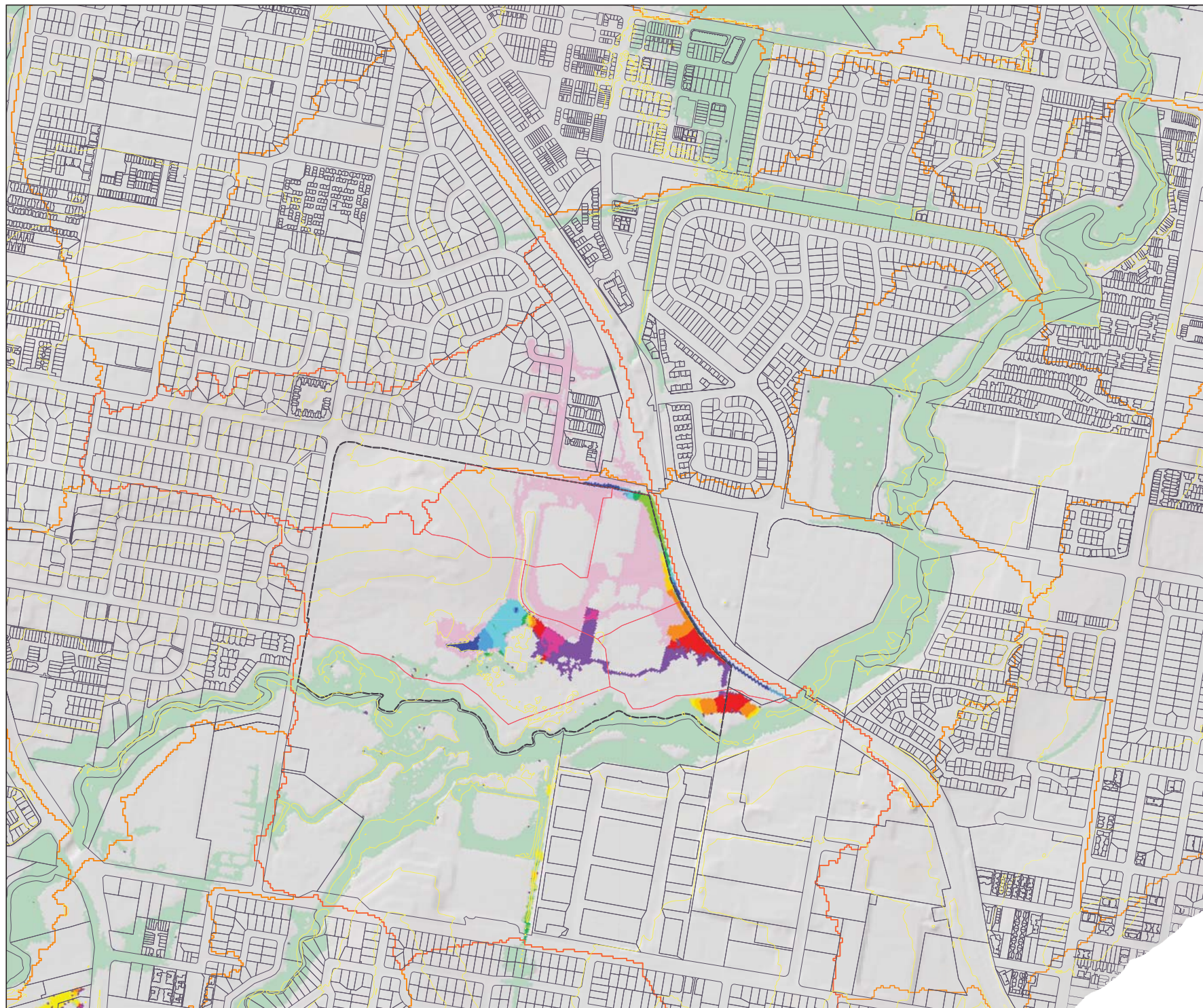

**(TUFLOW Case P02j Vs B01d)**

**%A QEP Event (5 20)**













Client: Economic Development Queensland



**LEGEND**

-  Site
-  Cadastral Data
-  LiDAR Contours (5m)
-  URBS Sub-Catchments (BCC)
-  Updated Sub-Catchments

**Impact (m)**

-  Less than -0.2
-  -0.1 to -0.2
-  -0.05 to -0.1
-  -0.02 to -0.05
-  -0.01 to -0.02
-  -0.01 to 0.01
-  0.01 to 0.02
-  0.02 to 0.05
-  0.05 to 0.1
-  0.1 to 0.2
-  Greater than 0.2
-  Was Wet - Now Dry
-  Was Dry - Now Wet

**FIGURE A11**

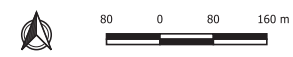

© Hydrology and Water Management Consulting Pty Ltd (HWMC) 2019.  
HWMC endeavours to ensure that the information contained in this figure is correct at the time of publication. Furthermore, HWMC makes no representations, warranties or guarantees about its accuracy.

**Carseldine Urban Village**

**Peak Flood Level Impacts  
Proposed Vs Existing Case**

**(TUFLOW Case P02j Vs B01d)**

**2%AEP Event (Q050)**

Client: Economic Development Queensland

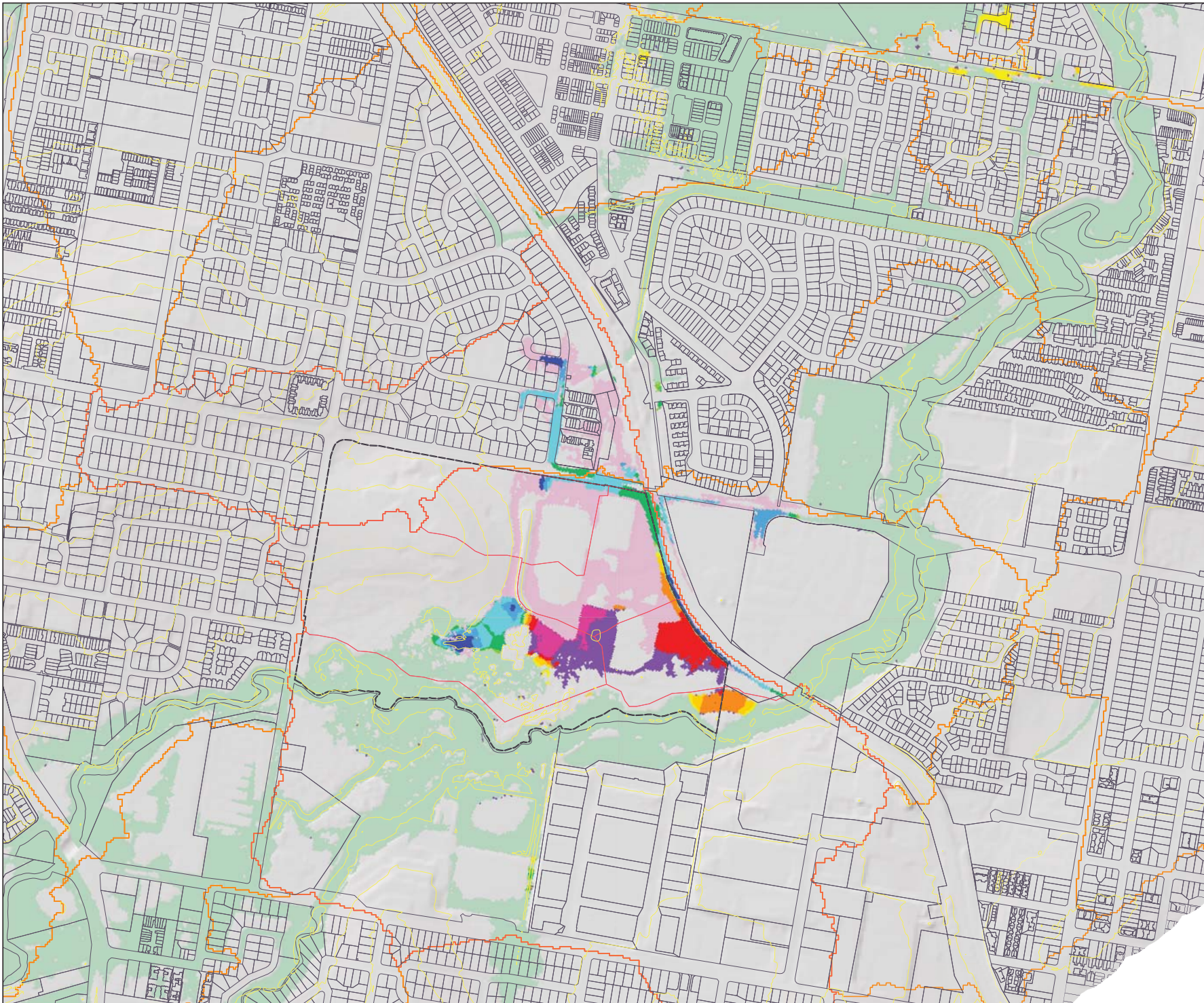

**LEGEND**

- Site
- Cadastral Data
- LiDAR Contours (5m)
- URBS Sub-Catchments (BCC)
- Updated Sub-Catchments

**Impact (m)**

- Less than -0.2
- 0.1 to -0.2
- 0.05 to -0.1
- 0.02 to -0.05
- 0.01 to -0.02
- 0.01 to 0.01
- 0.01 to 0.02
- 0.02 to 0.05
- 0.05 to 0.1
- 0.1 to 0.2
- Greater than 0.2
- Was Wet - Now Dry
- Was Dry - Now Wet

**FIGURE A12**



© Hydrology and Water Management Consulting Pty Ltd (HWMC) 2019.  
HWMC endeavours to ensure that the information contained in this figure is correct at the time of publication. Furthermore, HWMC makes no representations, warranties or guarantees about its accuracy.

**Carseldine Urban Village**

**Peak Flood Level Impacts  
Proposed Vs Existing Case**

**(TUFLOW Case P02j Vs B01d)**

**1% AEP Event (Q100)**

Client: Economic Development Queensland

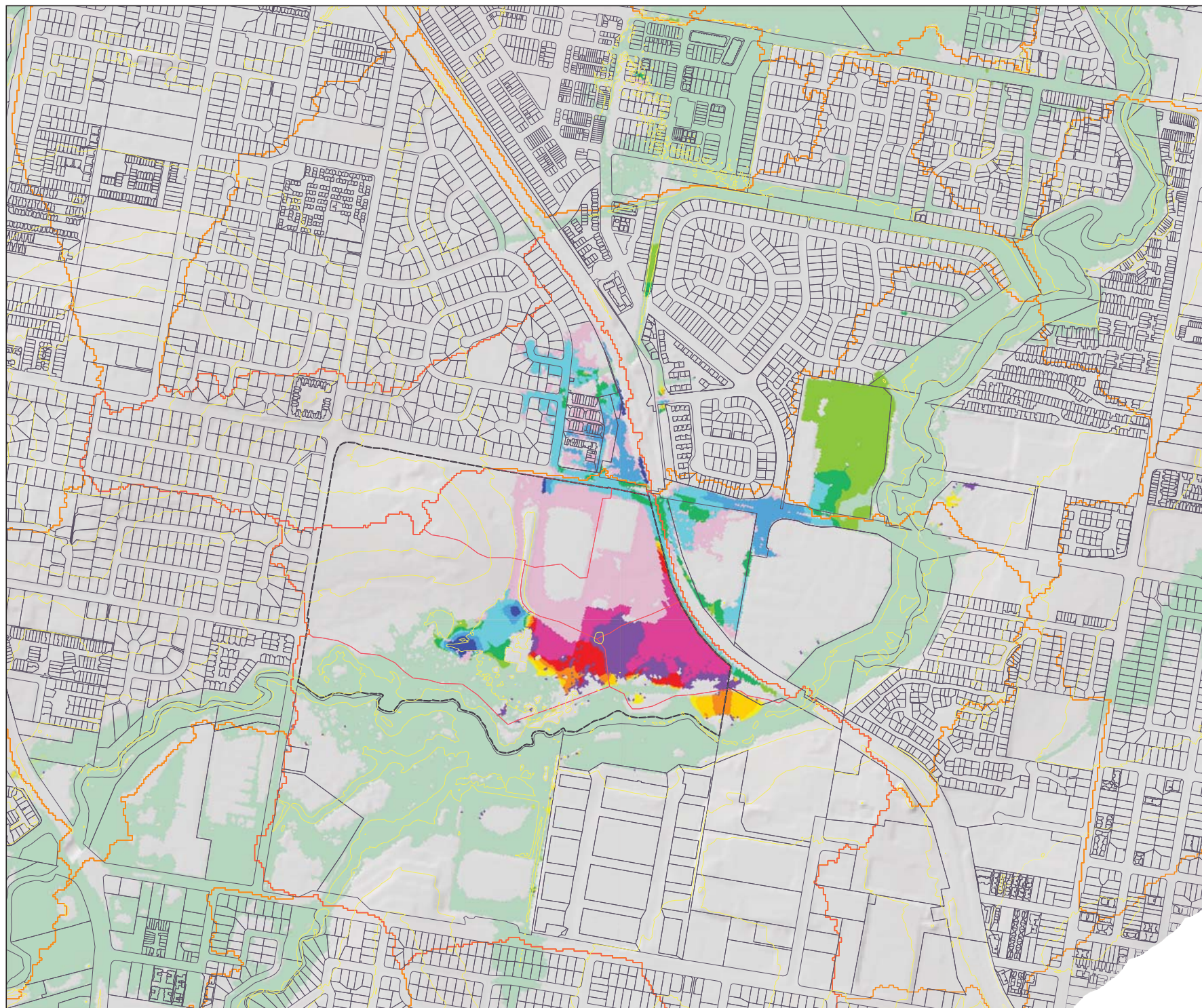



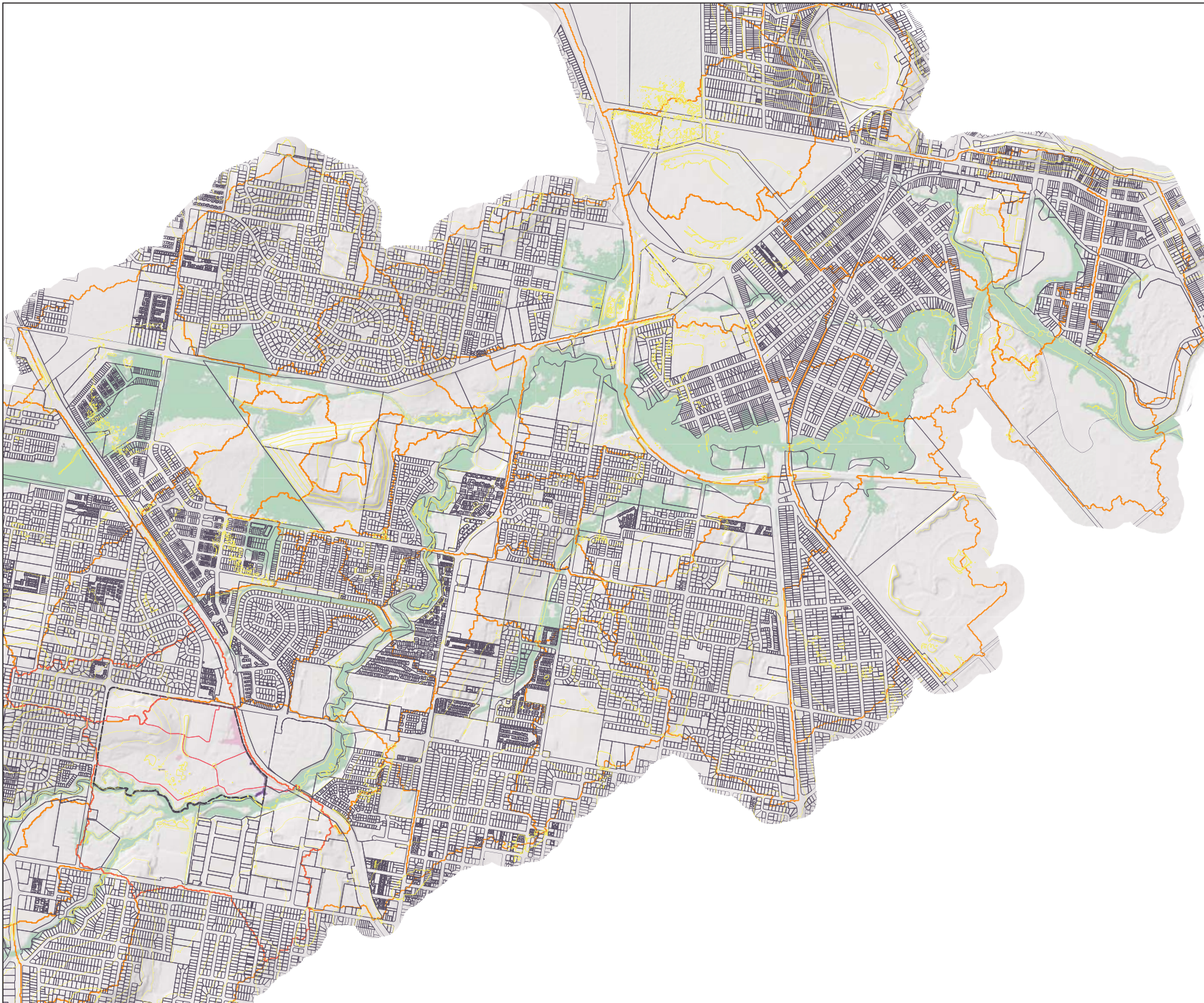

**LEGEND**

- Site
- Cadastral Data
- LiDAR Contours (5m)
- URBS Sub-Catchments (BCC)
- Updated Sub-Catchments

**Impact (m)**

- Less than -0.2
- 0.1 to -0.2
- 0.05 to -0.1
- 0.02 to -0.05
- 0.01 to -0.02
- 0.01 to 0.01
- 0.01 to 0.02
- 0.02 to 0.05
- 0.05 to 0.1
- 0.1 to 0.2
- Greater than 0.2
- Was Wet - Now Dry
- Was Dry - Now Wet

**FIGURE A13**

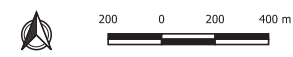

© Hydrology and Water Management Consulting Pty Ltd (HWMC) 2019.  
HWMC endeavours to ensure that the information contained in this figure is correct at the time of publication. Furthermore, HWMC makes no representations, warranties or guarantees about its accuracy.

**Carseldine Urban Village**





**Peak Flood Level Impacts  
Proposed Vs Existing Case**

**(TUFLOW Case P02j Vs B01d)**













**39% AEP Event (Q2)**

Client: Economic Development Queensland

**LEGEND**

-  Site
-  Cadastral Data
-  LiDAR Contours (5m)
-  URBS Sub-Catchments (BCC)
-  Updated Sub-Catchments

**Impact (m)**

-  Less than -0.2
-  -0.1 to -0.2
-  -0.05 to -0.1
-  -0.02 to -0.05
-  -0.01 to -0.02
-  -0.01 to 0.01
-  0.01 to 0.02
-  0.02 to 0.05
-  0.05 to 0.1
-  0.1 to 0.2
-  Greater than 0.2
-  Was Wet - Now Dry
-  Was Dry - Now Wet

**FIGURE A14**

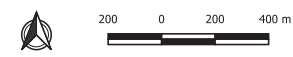

© Hydrology and Water Management Consulting Pty Ltd (HWMC) 2019.  
HWMC endeavours to ensure that the information contained in this figure is correct at the time of publication. Furthermore, HWMC makes no representations, warranties or guarantees about its accuracy.

**Carseldine Urban Village**

**Peak Flood Level Impacts  
Proposed Vs Existing Case**

**(TUFLOW Case P02j Vs B01d)**

**1%AEP Event (Q100)**

Client: Economic Development Queensland

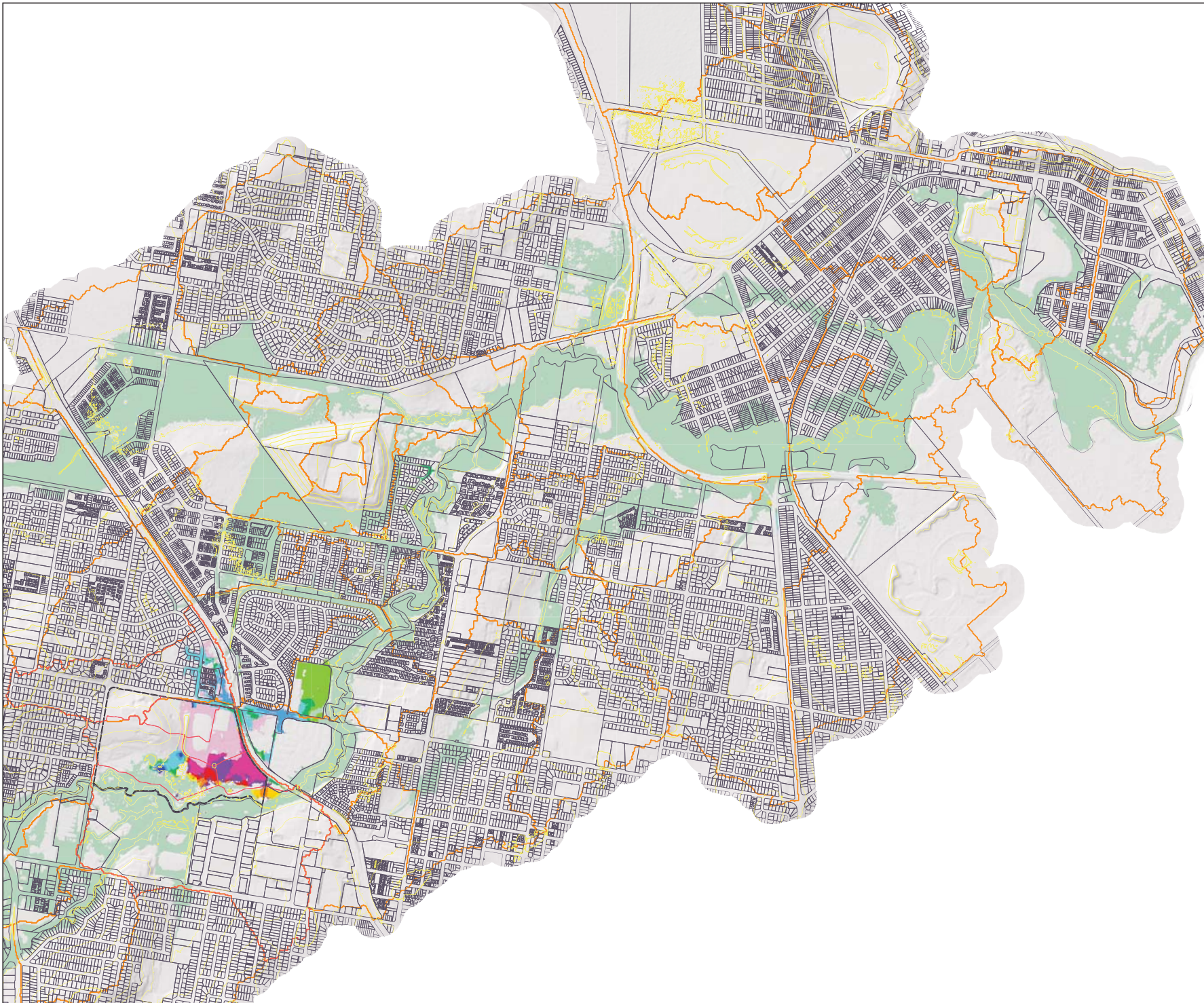



## Appendix E – Erosion Hazard Assessment



# Erosion Hazard Assessment - June 2014

Brisbane City Council (BCC), *Erosion Hazard Assessment* form must be read in conjunction with the *Erosion Hazard Assessment- Supporting Technical Notes* (June 2014 or later version) for explanatory terms and Certification information.

## What is an Erosion Hazard Assessment?

Soil erosion and sediment from urban development, particularly during construction activities, is a significant source of sediment pollution in Brisbane's waterways. The Erosion Hazard Assessment determines whether the risk of soil erosion and sediment pollution to the environment is 'low', 'medium' or 'high'.

## When is the EHA required?

An *Erosion Hazard Assessment* form must be completed and lodged with BCC for any Development Application (ie MCU or ROL) that will result in soil disturbance OR Operational Works or Compliance Assessment Application for 'Filling' or Excavation.

**Failure to submit this form during lodgement of an application may result in assessment delays or refusal of the application.**

## Privacy Statement

The personal information collected on this form will be used by Brisbane City Council for the purposes of fulfilling your request and undertaking associated Council functions and services. Your personal information will not be disclosed to any third party without your consent, unless this is required or permitted by law.

## Assessment Details

1 Please turn over and complete the erosion hazard assessment.

2 Based on the erosion hazard assessment overleaf, is the site:

A 'low' risk site

*Best practice erosion and sediment control (ESC) must be implemented but no erosion and sediment control plans need to be submitted with the development application. Factsheets outlining best practice ESC can be found at <http://www.waterbydesign.com.au/factsheets>*

A 'medium' risk site

*If the development is approved, the applicant will need to engage a Registered Professional Engineer (RPEQ) or Certified Professional in Erosion and Sediment Control (CPESC) to prepare an ESC Program and Plan and supporting documentation — in accordance with the requirements of the Infrastructure Design Planning Scheme Policy.*

A 'high' risk site

*If the development is approved, the applicant will need to engage a RPEQ and CPESC to prepare an ESC Program and Plan and supporting documentation — in accordance with the requirements of the Infrastructure Design Planning Scheme Policy. The plans and program will need to be certified by a CPESC.*

## 3 Site Information and Certification

Application number (if known)

Site address

41 & 49 Plaza Place, Carseldine

Postcode 4034

I certify that:

- I have made all relevant enquiries and am satisfied no matters of significance have been withheld from the assessment manager.
- I am a person with suitable qualifications and/or experience in erosion and sediment control.
- The Erosion Hazard Assessment was completed in accordance with the Erosion Hazard Assessment Supporting Technical Notes and the BCC Infrastructure Design Planning Scheme Policy.
- The Erosion Hazard Assessment accurately reflects the site's overall risk of soil erosion and sediment pollution to the environment.
- I acknowledge and accept that the BCC, as assessment manager, relies, in good faith, on this certification as part of its development assessment process and the provision of false or misleading information to the BCC constitutes an offence for which BCC may take punitive steps/ action against me/ enforcement action against me.

Certified by *Print name*

Callie Omlid

Certifier's signature

Date

17 / 07 / 2024

**Table 1: Low Risk Test**

|            |  | <b>Yes</b>                          | <b>No</b>                           |
|------------|--|-------------------------------------|-------------------------------------|
| <b>1.1</b> | is the area of land disturbance > 1000 m <sup>2</sup>  | <input checked="" type="checkbox"/> | <input type="checkbox"/>            |
| <b>1.2</b> | does any land disturbance occur in a BCC mapped waterway corridor  | <input type="checkbox"/>            | <input checked="" type="checkbox"/> |
| <b>1.3</b> | is there any slope on site (longer than three metres in length) before, during or after construction that is steeper than 5% | <input type="checkbox"/>            | <input checked="" type="checkbox"/> |
| <b>1.4</b> | does any land disturbance occur below 5 m AHD  | <input type="checkbox"/>            | <input checked="" type="checkbox"/> |
| <b>1.5</b> | does development involve endorsement of a staging plan   | <input type="checkbox"/>            | <input checked="" type="checkbox"/> |
| <b>1.6</b> | is there an upstream catchment passing through the site > 1 hectare  | <input type="checkbox"/>            | <input checked="" type="checkbox"/> |

Have you answered 'yes' to any of the questions in Table 1?

| <b>Yes</b>                          | <b>No</b>                |
|-------------------------------------|--------------------------|
| <input checked="" type="checkbox"/> | <input type="checkbox"/> |

If 'No' then site is **low risk** with respect to erosion and sediment control

If 'Yes' then proceed to Table 2

**Table 2: Medium Risk Test**

|            |   | <b>Yes</b>               | <b>No</b>                           |
|------------|---|--------------------------|-------------------------------------|
| <b>2.1</b> | is the area of land disturbance > 1 hectare | <input type="checkbox"/> | <input checked="" type="checkbox"/> |

If 'No' then site is **medium risk** with respect to erosion and sediment control

If 'Yes' then proceed to Table 3

**Table 3: High Risk Test**

|            |   |                          |                          |
|------------|---|--------------------------|--------------------------|
| <b>3.1</b> | is there an upstream catchment passing through the site > 1 hectare   | <input type="checkbox"/> | <input type="checkbox"/> |
| <b>3.2</b> | does any land disturbance occurs in a BCC mapped waterway corridor  | <input type="checkbox"/> | <input type="checkbox"/> |
| <b>3.3</b> | is there any slope on site (longer than three metres in length) before, during or after construction that is steeper than 15% | <input type="checkbox"/> | <input type="checkbox"/> |

Have you answered 'yes' to any of the questions in Table 3?

| <b>Yes</b>               | <b>No</b>                |
|--------------------------|--------------------------|
| <input type="checkbox"/> | <input type="checkbox"/> |

If 'No' then site is **medium risk** with respect to erosion and sediment control

If 'Yes' then site is **high risk** with respect to erosion and sediment control



## Appendix F – BCC Codes

Project Location: 41 & 49 Plaza Place, Carseldine Job Reference: 10898

## BCC – Filling and Excavation Code

| Performance outcomes   | Acceptable outcomes  | Solutions*       | Comments  | Council Use |
|--|--|------------------|---|-------------|
| <p><b>PO1</b></p> <p>Development for filling or excavation minimises visual impacts from retaining walls and earthworks.</p>   | <p><b>AO1</b></p> <p>Development ensures that the total height of any cut and fill, whether or not retained, does not exceed:</p> <p>(a) 2.5m in a zone in the Industry zones category;</p> <p>(b) 1m in all other zones, or if adjoining a sensitive zone.</p>  | <p><b>AO</b></p> | <p>The proposed retaining walls and earthworks will not create adverse visual impacts to the surrounding properties.</p>  |             |
| <p><b>PO2</b></p> <p>Development of a retaining wall proposed as a result of filling or excavation:</p> <p>(a) is designed and constructed to be fit for purpose;</p> <p>(b) does not impact adversely on significant vegetation;</p> <p>(c) is capable of easy maintenance.</p> <p>Editor’s note—A retaining wall also needs to comply with the Building Regulation and embankment gradients will need to comply with the Building Regulation.</p> <p>Note—Guidance on the protection of native</p> | <p><b>AO2.1</b></p> <p>Development of a retaining structure, including footings, surface drainage and subsoil drainage:</p> <p>a) is wholly contained within the site;</p> <p>b) if the total height to be retained is greater than 1m, then:</p> <p>(i) the retaining wall at the property boundary is no greater than 1m above the ground level;</p> <p>(ii) all further terracing from the 1m high boundary retaining wall is 1 vertical unit:1 horizontal unit;</p> <p>(iii) the distance between each successive retaining wall (back</p> | <p><b>AO</b></p> | <p>No significant vegetation is located in or near the subject site.</p> <p>Retaining wall finishes will be acceptable to Council standards.</p> <p>Clean fill will be used where required.</p> |             |

| Performance outcomes   | Acceptable outcomes   | Solutions* | Comments | Council Use |
|--|---|------------|----------|-------------|
| vegetation is included in the Biodiversity areas planning scheme policy. | of lower wall to face of higher wall) is no less than 1m horizontally to incorporate planting areas.  |            |          |             |
|  | <b>AO2.2</b><br>Development of a retaining wall over 1m in height protects significant vegetation on the site and on adjoining land and is designed and constructed in accordance with the structures standards in the Infrastructure design planning scheme policy and certified by a Registered Professional Engineer Queensland. |            |          |             |
|  | <b>AO2.3</b><br>Development provides a retaining wall finish that presents to adjoining land that is maintenance free if the setback is less than 750mm from the boundary.  |            |          |             |
|  | <b>AO2.4</b><br>Development for filling only uses clean fill that does not include any construction rubble, debris, weed seed or viable parts of plant species listed as an undesirable plant species in the Planting species planning scheme policy.   |            |          |             |



| Performance outcomes   | Acceptable outcomes  | Solutions* | Comments   | Council Use |
|--|--|------------|--|-------------|
| <p><b>PO3</b></p> <p>Development ensures that a rock anchor is designed and constructed to be fit for purpose.</p>   | <p><b>AO3</b></p> <p>Development ensures that a rock anchor:</p> <ul style="list-style-type: none"> <li>a) is constructed in accordance with the standards in the Infrastructure design planning scheme policy;</li> <li>b) where it extends beyond the property boundary, is supported by a letter of consent from the adjoining land and building owners.</li> </ul> | N/A        | No rock anchors are required as a part of this development   |             |
| <p><b>PO4</b></p> <p>Development protects all services and public utilities.</p>   | <p><b>AO4</b></p> <p>Development protects services and public utilities and ensures that any alteration or relocation of services or public utilities meets the standard design specifications of the responsible service authorities.</p>   | AO         | Construction of the development will take necessary precautions and actions to ensure the protection of existing services and public utilities.  |             |
| <p><b>PO5</b></p> <p>Development provides surface and sub-surface drainage to prevent water seepage, concentration of run-off or ponding of stormwater on adjacent land.</p> | <p><b>AO5</b></p> <p>Development ensures all flows and subsoil drainage are directed to a lawful point of discharge of a surface water diversion drain, including to the top or toe of a retaining wall in accordance with the stormwater drainage section of the Infrastructure design planning scheme policy.</p>  | AO         | <p>Acceptable surface drainage has been designed in accordance with the infrastructure design planning scheme policy.</p> <p>Appropriate subsoil drainage will be designed at the detailed design stage according to the infrastructure design planning scheme policy.</p> |             |
| <p><b>PO6</b></p> <p>Development ensures that the design and construction of all open drainage works is undertaken in accordance with natural</p>                            | <p><b>AO6</b></p> <p>Filling or excavation does not involve the construction of open drainage.</p>   | AO         | No major open drainage works are proposed as a part of the development.  |             |

| Performance outcomes   | Acceptable outcomes   | Solutions*       | Comments   | Council Use |
|--|---|------------------|--|-------------|
| <p>channel design principles, being the development of a stormwater conveyance system for major flows, by using a vegetated open channel or drain that approximates the features and functions of a natural waterway to enhance or improve riparian values of those stormwater conveyance systems.</p> <p>Editor’s note—Guidance on natural channel design principles can be found in the Council’s publication Natural channel design guidelines.</p> |   |                  |  |             |
| <p><b>PO7</b></p> <p>Development for filling or excavation:</p> <p>a) does not degrade water quality or adversely affect environmental values in receiving waters;</p> <p>b) ensures site sediment and erosion control standards are best practice.</p>  | <p><b>AO7.1</b></p> <p>Development for filling or excavation provides water quality treatment that complies with the stormwater drainage section of the Infrastructure design planning scheme policy.</p> | <p><b>AO</b></p> | <p>Water quality treatment has been designed in accordance with the infrastructure design planning scheme policy and the State Planning Policy.</p> <p>An erosion and sediment control plan will be designed at the detailed design stage and will be in accordance with the infrastructure design planning scheme policy.</p> |             |
| <p><b>AO7.2</b></p> <p>Development provides erosion and sediment control standards that are in accordance with the stormwater drainage section of the Infrastructure design planning scheme policy.</p>  |   |                  |  |             |
| <p><b>PO8</b></p> <p>Development for filling or excavation is conducted such that adverse impacts at a sensitive use due to noise and dust are prevented or minimised.</p>   | <p><b>AO8.1</b></p> <p>Development ensures that no dust emissions extend beyond the boundary of the site, including dust from construction vehicles entering and leaving the site.</p>                    | <p><b>AO</b></p> | <p>Erosion and sediment control measures will be implemented on site to ensure no dust emissions.</p> <p>Earthworks will be restricted to the</p>  |             |

| Performance outcomes   | Acceptable outcomes  | Solutions* | Comments  | Council Use |
|--|--|------------|---|-------------|
| Note—A noise and dust impact management plan prepared in accordance with the Management plans planning scheme policy can assist in demonstrating achievement of this performance outcome.  | <b>AO8.2</b><br>Development for filling or excavation activity only occurs between the hours of 6:30am and 6:30pm Monday to Saturday, excluding public holidays.   |            | recommended working hours.  |             |
| <b>PO9</b><br>Development ensures that vibration generated by the filling or excavation operation does not exceed the vibration criteria in Table 9.4.3.3.B, Table 9.4.3.3.C, Table 9.4.3.3.D and Table 9.4.3.3.E.<br><br>Note—A noise management report prepared in accordance with the Noise impact assessment planning scheme policy can assist in demonstrating achievement of this performance outcome. | <b>AO9</b><br>Development involving filling or excavation does not cause a ground-borne vibration beyond the boundary of the site.   | <b>AO</b>  | Filling and excavation activities undertaken on site will ensure that ground-borne vibration does not exceed the criteria set out by BCC. |             |
| <b>PO10</b><br>Development ensures that heavy trucks hauling material to and from the site do not affect the amenity of established areas and limits environmental nuisance impact on adjacent land.   | <b>AO10</b><br>Development ensures that heavy trucks hauling material to and from the site:<br>a) occur for a maximum of 3 weeks;<br>b) use a major road to access the site;<br>c) only use a minor road for the shortest-most-direct route that has the least amount of environmental nuisance if there is no major road alternative. | <b>AO</b>  | Truck movements to and from site will be restricted as per BCC guidelines.  |             |
| <b>PO11</b><br>Development for filling or excavation   | <b>AO11</b><br>Development does not involve:   | <b>AO</b>  | Due to the existing nature of the site it is not expected that the site is listed on the contaminated land register. A search can         |             |

| Performance outcomes   | Acceptable outcomes   | Solutions* | Comments   | Council Use |
|--|---|------------|--|-------------|
| protects the environment and community health and wellbeing from exposure to contaminated land and contaminated material.  | a) excavation on land previously occupied by a notifiable activity or on land listed on the Environmental Management Register or the Contaminated Land Register;<br>b) filling with material containing a contaminant.  |            | be undertaken if requested.<br><br>All fill material sourced for the development will be free of contaminants.   |             |
| <b>PO12</b><br>Development provides for:<br>a) landscaping for water conservation purposes;<br>b) water sensitive urban design measures which are employed within the landscape design to maximise stormwater use and to reduce any adverse impacts on the landscape;<br>c) stormwater harvesting to be maximised and any adverse impacts of stormwater minimised. | <b>AO12.1</b><br>Development provides landscaping which is designed using the standards in the Landscape design guidelines for water conservation planning scheme policy.<br><b>AO12.2</b><br>Development ensures that the design and requirements for irrigation are in compliance with the standards in the Landscape design guidelines for water conservation planning scheme policy.<br><b>AO12.3</b><br>Development provides areas of pavement, turf and mulched garden beds which are drained.<br>Note—This may be achieved through the provision and/or treatment of swales, spoon drains, field gullies, sub-surface drainage and stormwater connections. | <b>AO</b>  | Landscaping areas are provided throughout the proposed development. Where appropriate, surface drainage has been provided to remove excess runoff from the site. |             |
| <b>PO13</b>  | <b>AO13</b>   | <b>AO</b>  | The development does not involve the   |             |

| Performance outcomes   | Acceptable outcomes  | Solutions* | Comments                                    | Council Use |
|--|--|------------|---|-------------|
| Development ensures cutting and filling for the development of canals or artificial waterways avoids adverse impacts on coastal resources and processes. | Development does not involve the creation of canals or artificial waterways. |            | creation of canals or artificial waterways. |             |

## BCC – Stormwater Code

| Performance outcomes  | Acceptable outcomes  | Solutions*       | Comments  | Council Use |
|---|--|------------------|---|-------------|
| <p><b>Section A—If for a material change of use, reconfiguring a lot, operational work or building work</b></p> <p><b>Note—Compliance with the performance outcomes and acceptable outcomes in this section should be demonstrated by the submission of a site-based stormwater management plan for high risk development only.</b></p>   |  |                  |   |             |
| <p><b>PO1</b></p> <p>Development provides a stormwater management system which achieves the integrated management of stormwater to:</p> <ul style="list-style-type: none"> <li>(c) minimise flooding;</li> <li>(d) protect environmental values of receiving waters;</li> <li>(e) maximise the use of water sensitive urban design;</li> <li>(f) minimise safety risk to all persons;</li> <li>(g) maximise the use of natural waterway corridors and natural channel design principles.</li> </ul> <p>Editor’s note—The stormwater management system to be developed to address PO1 is not intended to require management of stormwater quality.</p> | <p><b>AO1</b></p> <p>Development provides a stormwater management system designed in compliance with the Infrastructure design planning scheme policy.</p> | <p><b>AO</b></p> | <p>The proposed stormwater quantity and quality management system is designed in accordance with the Infrastructure design planning scheme policy.</p> <p>Please refer to the report for further design details relating to the stormwater management system.</p> <p>Please also refer to the existing and developed catchment plans and the proposed stormwater drainage layout.</p> |             |
| <p><b>PO2</b></p> <p>Development ensures that the stormwater management system and site work does not adversely impact</p>  | <p><b>AO2.1</b></p> <p>Development does not result in an increase in flood level or flood hazard on up slope, down slope or adjacent premises.</p>         | <p><b>AO</b></p> | <p>The proposed stormwater management system is designed in compliance with the standards in the Infrastructure design planning scheme policy and will not result in an increase in flood level or</p>  |             |

| Performance outcomes   | Acceptable outcomes   | Solutions* | Comments  | Council Use |
|--|---|------------|---|-------------|
| flooding or drainage characteristics of premises which are up slope, down slope or adjacent to the site.   | <b>AO2.2</b><br>Development provides a stormwater management system which is designed in compliance with the standards in the Infrastructure design planning scheme policy.   |            | flood hazard on upstream, downstream or surrounding properties.   |             |
| <b>PO3</b><br>Development ensures that the stormwater management system does not direct stormwater run-off through existing or proposed lots and property where it is likely to adversely affect the safety of, or cause nuisance to properties. | <b>AO3.1</b><br>Development ensures that the location of the stormwater drainage system is contained within a road reserve, drainage reserve, public pathway, park or waterway corridor.<br><b>AO3.2</b><br>Development provides a stormwater management system which is designed in compliance with the standards in the Infrastructure design planning scheme policy.<br><b>AO3.3</b><br>Development obtains a lawful point of discharge in compliance with the standards in the Infrastructure design planning scheme policy.<br><b>AO3.4</b><br>Where on private land, all underground stormwater infrastructure is secured by a drainage easement. | <b>AO</b>  | The stormwater management system and lawful point of discharge is in compliance with the infrastructure design planning scheme policy.<br><br>Easements have been provided over stormwater infrastructure where applicable. |             |
| <b>PO4</b>   | <b>AO4.1</b>  | <b>AO</b>  | The development provides a stormwater   |             |

| Performance outcomes   | Acceptable outcomes   | Solutions* | Comments   | Council Use |
|--|---|------------|--|-------------|
| Development provides a stormwater management system which has sufficient capacity to safely convey run-off taking into account increased run-off from impervious surfaces and flooding in local catchments.  | Development provides a stormwater conveyance system which is designed to safely convey flows in compliance with the standards in the Infrastructure design planning scheme policy.                    |            | conveyance system which is designed to safely convey stormwater runoff in accordance with the infrastructure design planning scheme policy.  |             |
|  | <b>AO4.2</b><br>Development provides sufficient area to convey run-off which will comply with the standards in the Infrastructure design planning scheme policy.                                      |            | The development provides sufficient area to convey runoff in accordance with the infrastructure design planning scheme policy.   |             |
| <b>PO5</b><br>Development designs stormwater channels, creek modification works, bridges, culverts and major drains to protect and enhance the value of the waterway corridor or drainage path for fauna movement.   | <b>AO5</b><br>Development ensures the design of stormwater channels, creek modifications or other infrastructure, permits terrestrial and aquatic fauna movement.                                     | <b>N/A</b> | No stormwater channels or creek modification works are proposed as a part of the development.  |             |
| <b>PO6</b><br>Development ensures that location and design of stormwater detention and water quality treatment:<br>a) minimises risk to people and property;<br>b) provides for safe access and maintenance;<br>c) minimises ecological impacts to creeks and waterways. | <b>AO6.1</b><br>Development locates stormwater detention and water quality treatment:<br>a) outside of a waterway corridor;<br>b) offline to any catchment not contained within the development.      | <b>AO</b>  | The proposed stormwater quality and quantity management system is not located within a waterway corridor and is in accordance with the Infrastructure design planning scheme policy. |             |
|  | <b>AO6.2</b><br>Development providing for stormwater detention and water quality treatment devices are designed in compliance with the standards in the Infrastructure design planning scheme policy. |            |  |             |



| Performance outcomes   | Acceptable outcomes   | Solutions*       | Comments  | Council Use |
|--|---|------------------|---|-------------|
| <p><b>PO7</b></p> <p>Development is designed, including any car parking areas and channel works to:</p> <ul style="list-style-type: none"> <li>a) reduce property damage;</li> <li>b) provide safe access to the site during the defined flood event.</li> </ul> | <p><b>AO7.1</b></p> <p>Development (including any ancillary structures and car parking areas) is located above minimum flood immunity levels in Table 9.4.9.3.B, Table 9.4.9.3.C, Table 9.4.9.3.D, Table 9.4.9.3.E and Table 9.4.9.3.F.</p> <p>Note—Compliance with this acceptable outcome can be demonstrated by the submission of a hydraulic and hydrology report identifying flood levels and development design levels (as part of a site-based stormwater management plan).</p> <hr/> <p><b>AO7.2</b></p> <p>Development including the road network provides a stormwater management system that provides safe pedestrian and vehicle access in accordance with the standards in the Infrastructure design planning scheme policy.</p> | <p><b>AO</b></p> | <p>The development achieves the minimum flood immunity levels nominated.</p> <p>Safe pedestrian and vehicle access has been designed in accordance with the planning scheme policy.</p>                         |             |
| <p><b>PO8</b></p> <p>Development designs stormwater channels, creek modification works and the drainage network to protect and enhance the environmental values of the waterway corridor or drainage path.</p>   | <p><b>AO8.1</b></p> <p>Development ensures natural waterway corridors and drainage paths are retained.</p> <hr/> <p><b>AO8.2</b></p> <p>Development provides the required hydraulic conveyance of the drainage channel and floodway, while maximising its potential to maximise environmental benefits and minimise scour.</p>  | <p><b>AO</b></p> | <p>Development ensures natural waterway corridors and drainage paths are retained.</p> <p>Appropriate energy dissipation devices have been provided at stormwater outlets to minimise scour where required.</p> |             |

| Performance outcomes   | Acceptable outcomes   | Solutions*       | Comments   | Council Use |
|--|---|------------------|--|-------------|
|  | <p>Editor’s note—Guidance on natural channel design principles can be found in the Council’s publication Natural channel design guidelines.</p> <p><b>A08.3</b><br/>Development provides stormwater outlets into waterways, creeks, wetlands and overland flow paths with energy dissipation to minimise scour in compliance with the standards in the Infrastructure design planning scheme policy.</p> <p><b>A08.4</b><br/>Development ensures that the design of modifications to the existing design of new stormwater channels, creeks and major drains is in compliance with the standards in the Infrastructure design planning scheme policy.</p> |                  |  |             |
| <p><b>PO9</b><br/>Development is designed to manage run-off and peak flows by minimising large areas of impervious material and maximising opportunities for capture and re-use.</p> | <p><b>A09</b><br/>No acceptable outcome is prescribed.</p>  | <p><b>PO</b></p> | <p>Development has incorporated landscaping to minimise impervious area and allowed for stormwater re-use where appropriate.</p> |             |
| <p><b>PO10</b><br/>Development ensures that there is sufficient site area to accommodate an effective stormwater management</p>  | <p><b>AO10</b><br/>No acceptable outcome is prescribed.</p>   | <p><b>PO</b></p> | <p>There is sufficient area on-site to accommodate an effective stormwater management system.</p>                                |             |

| Performance outcomes   | Acceptable outcomes  | Solutions*       | Comments  | Council Use |
|--|--|------------------|---|-------------|
| <p>system.</p> <p>Note—Compliance with the performance outcome should be demonstrated by the submission of a site-based stormwater management plan for high-risk development only.</p>   |  |                  |   |             |
| <p><b>PO11</b></p> <p>Development provides for the orderly development of stormwater infrastructure within a catchment, having regard to the:</p> <ul style="list-style-type: none"> <li>a) existing capacity of stormwater infrastructure within and external to the site, and any planned stormwater infrastructure upgrades;</li> <li>b) safe management of stormwater discharge from existing and future up-slope development;</li> <li>c) implication for adjacent and down-slope development.</li> </ul> | <p><b>AO11.1</b></p> <p>Development with up-slope external catchment areas provides a drainage connection sized for ultimate catchment conditions that is directed to a lawful point of discharge.</p> <hr/> <p><b>AO11.2</b></p> <p>Development ensures that existing stormwater infrastructure that is undersized is upgraded in compliance with the Infrastructure design planning scheme policy.</p> | <p><b>AO</b></p> | <p>There are no major external catchments draining through the site that need to be provided with a drainage connection.</p>  |             |
| <p><b>PO12</b></p> <p>Development provides stormwater infrastructure which:</p> <ul style="list-style-type: none"> <li>a) remains fit for purpose for the life of the development and maintains full functionality in the design flood event;</li> <li>b) can be safely accessed and maintained cost effectively;</li> <li>c) ensures no structural damage to</li> </ul>   | <p><b>AO12.1</b></p> <p>The stormwater management system is designed in compliance with the Infrastructure design planning scheme policy.</p> <hr/> <p><b>AO12.2</b></p> <p>Development provides a clear area with a minimum of 2m radius from the centre of an existing manhole cover and with a</p>  | <p><b>AO</b></p> | <p>The stormwater management system is in compliance with the infrastructure design planning scheme policy.</p> <p>No existing stormwater manholes are located on the subject site.</p> |             |

| Performance outcomes  | Acceptable outcomes  | Solutions*       | Comments   | Council Use |
|---|--|------------------|--|-------------|
| existing stormwater infrastructure.   | minimum height clearance of 2.5m.                              |                  |  |             |
| <p><b>PO13</b></p> <p>Development ensures that all reasonable and practicable measures are taken to manage the impacts of erosion, turbidity and sedimentation, both within and external to the development site from construction activities, including vegetation clearing, earthworks, civil construction, installation of services, rehabilitation, revegetation and landscaping to protect:</p> <ul style="list-style-type: none"> <li>a) the environmental values and water quality objectives of waters;</li> <li>b) waterway hydrology;</li> <li>c) the maintenance and serviceability of stormwater infrastructure.</li> </ul> <p>Note—The Infrastructure design planning scheme policy outlines the appropriate measures to be taken into account to achieve the performance outcome.</p> | <p><b>AO13</b></p> <p>No acceptable outcome is prescribed.</p> | <p><b>PO</b></p> | <p>An erosion and sediment control plan will be designed at the detailed design stage, which will incorporate industry best practice methods to reduce any possible impacts to receiving waters and stormwater infrastructure.</p> |             |
| <p><b>PO14</b></p> <p>Development ensures that:</p> <ul style="list-style-type: none"> <li>a) unnecessary disturbance to soil, waterways or drainage channels is avoided;</li> <li>b) all soil surfaces remain effectively stabilised against erosion in the short</li> </ul>   | <p><b>AO14</b></p> <p>No acceptable outcome is prescribed.</p> | <p><b>PO</b></p> | <p>The development will avoid unnecessary disturbance to soil, waterways and drainage channels and erosion control measures will be implemented for both short and long term stabilisation.</p>                                    |             |

| Performance outcomes   | Acceptable outcomes   | Solutions*       | Comments   | Council Use |
|--|---|------------------|--|-------------|
| and long term.   |   |                  |  |             |
| <p><b>PO15</b></p> <p>Development does not increase:</p> <p>a) the concentration of total suspended solids or other contaminants in stormwater flows during site construction;</p> <p>b) run-off which causes erosion either on site or off site.</p>  | <p><b>AO15</b></p> <p>No acceptable outcome is prescribed.</p>  | <p><b>PO</b></p> | <p>The development will be designed to minimise increases in run-off and TSS concentrations during construction.</p>                                       |             |
| <p><b>Section B—Additional performance outcomes and acceptable outcomes which apply to high-risk development, being one or more of the following:</b></p> <p>a) a material change of use for an urban purpose which involves greater than 2,500m<sup>2</sup> of land that:</p> <ul style="list-style-type: none"> <li>i. will result in an impervious area greater than 25% of the net developable area; or</li> <li>ii. will result in 6 or more dwellings.</li> </ul> <p>b) reconfiguring a lot for an urban purpose that involves greater than 2,500m<sup>2</sup> of land and will result in 6 or more lots;</p> <p>c) operational work for an urban purpose which involves disturbing greater than 2,500m<sup>2</sup> of land.</p> |   |                  |  |             |
| <p><b>PO16</b></p> <p>Development ensures that the entry and transport of contaminants into stormwater is avoided or minimised to protect receiving water environmental values.</p> <p>Note—Prescribed water contaminants are defined in the <i>Environmental Protection Act 1994</i>.</p>   | <p><b>AO16</b></p> <p>Development provides a stormwater management system which is designed in compliance with the standards in the Infrastructure design planning scheme policy.</p> | <p><b>AO</b></p> | <p>The proposed stormwater quality management system is designed in accordance with the standards in the Infrastructure design planning scheme policy.</p> |             |

| Performance outcomes   | Acceptable outcomes  | Solutions*       | Comments  | Council Use |
|--|--|------------------|---|-------------|
| <p><b>PO17</b></p> <p>Development ensures that:</p> <ul style="list-style-type: none"> <li>a) the discharge of wastewater to a waterway or external to the site is avoided; or</li> <li>b) if the discharge cannot practicably be avoided, the development minimises wastewater discharge through re-use, recycling, recovery and treatment.</li> </ul> <p>Note—The preparation of a wastewater management plan can assist in demonstrating achievement of this performance outcome.</p> <p>Editor’s note—This code does not deal with sewerage which is the subject of the Wastewater code.</p> | <p><b>AO17</b></p> <p>No acceptable outcome is prescribed.</p>   | <p><b>PO</b></p> | <p>The development will ensure that wastewater discharge is managed in accordance with the Infrastructure design planning scheme policy.</p>  |             |
| <p><b>Section C—Additional performance outcomes and acceptable outcomes for assessable development for a material change of use or reconfiguring a lot</b></p>   |  |                  |   |             |
| <p><b>PO18</b></p> <p>Development protects stormwater infrastructure to ensure the following are not compromised:</p> <ul style="list-style-type: none"> <li>a) the long term infrastructure for the stormwater network in the Long term infrastructure plans;</li> <li>b) the existing and planned infrastructure for the stormwater network in the</li> </ul>  | <p><b>AO18</b></p> <p>Development protects stormwater infrastructure in compliance with the following:</p> <ul style="list-style-type: none"> <li>a) for long term infrastructure for the stormwater network, the Long term infrastructure plans;</li> <li>b) for existing and planned infrastructure for the stormwater network, the Local</li> </ul> | <p><b>AO</b></p> | <p>The development will not adversely impact on existing or future planned stormwater infrastructure and is in compliance with the standards of the Infrastructure design planning scheme policy.</p> |             |

| Performance outcomes  | Acceptable outcomes   | Solutions*       | Comments  | Council Use |
|---|---|------------------|---|-------------|
| <p>Local government infrastructure plan;</p> <p>c) the provision of long term, existing and planned infrastructure for the stormwater network which:</p> <ul style="list-style-type: none"> <li>I. is required to service the development or an existing and future urban development in the planning scheme area; or</li> <li>II. is in the interests of rational development or the efficient and orderly planning of the general area in which the site is situated.</li> </ul> <p>Editor's note—A condition which requires a proposed development to keep permanent improvements and structures associated with the approved development clear of the area of long term infrastructure, may be imposed.</p> | <p>government infrastructure plan;</p> <p>c) the standards for stormwater drainage in the Infrastructure design planning scheme policy.</p> |                  |   |             |
| <p><b>PO19</b></p> <p>Development provides for the payment of extra trunk infrastructure costs for the following:</p> <ul style="list-style-type: none"> <li>a) for development completely or partly outside the priority infrastructure area in the Local government infrastructure plan;</li> <li>b) for development completely inside the priority infrastructure area in the Local government infrastructure plan</li> </ul>  | <p><b>AO19</b></p> <p>No acceptable outcome is prescribed.</p>  | <p><b>PO</b></p> | <p>The developer will pay the appropriate infrastructure costs in accordance with Council's infrastructure plans.</p> |             |

| Performance outcomes   | Acceptable outcomes | Solutions* | Comments | Council Use |
|--|---------------------|------------|----------|-------------|
| <p>involving:</p> <ul style="list-style-type: none"> <li>I. trunk infrastructure that is to be provided earlier than planned in the Local government infrastructure plan;</li> <li>II. long term infrastructure for the stormwater network which is made necessary by development that is not assumed future urban development;</li> <li>III. other infrastructure for the stormwater network associated with development that is not assumed future urban development which is made necessary by the development.</li> </ul> <p>Editor's note—The payment of extra trunk infrastructure costs for development completely inside the priority infrastructure area in the Local government infrastructure plan is to be worked out in accordance with the Charges Resolution.</p> <p>Editor's note—See section 130 Imposing Development conditions (Conditions for extra trunk infrastructure costs) of the <i>Planning Act 2016</i>.</p> |                     |            |          |             |



## BCC – Infrastructure Design Code

| Performance outcomes   | Acceptable outcomes   | Solutions*       | Comments  | Council Use |
|--|---|------------------|---|-------------|
| <p><b>PO1</b></p> <p>Development provides roads, pavement, edging and landscaping which:</p> <ul style="list-style-type: none"> <li>a) are designed and constructed in accordance with the road hierarchy;</li> <li>b) provide for safe travel for pedestrians, cyclists and vehicles;</li> <li>c) provide access to properties for all modes;</li> <li>d) provide utilities;</li> <li>e) provide high levels of aesthetics and amenity, improved liveability and future growth;</li> <li>f) provide for the amelioration of noise and other pollution;</li> <li>g) provide a high-quality streetscape;</li> <li>h) provide a low-maintenance asset with a minimal whole-of-life cost.</li> </ul> <p>Note—This can be demonstrated in an engineering report prepared and certified by a Registered Professional Engineer Queensland in accordance with the Infrastructure design planning scheme policy.</p> | <p><b>AO1</b></p> <p>Development provides roads and associated pavement, edging and landscaping which are designed and constructed in compliance with the road corridor design standards in the Infrastructure design planning scheme policy.</p> | <p><b>AO</b></p> | <p>The development will provide pavement, edging and landscaping to be in compliance with the road corridor design standards in the infrastructure design planning scheme policy.</p> |             |

| Performance outcomes   | Acceptable outcomes  | Solutions*       | Comments  | Council Use |
|--|--|------------------|---|-------------|
| <p><b>PO2</b></p> <p>Development provides road pavement surfaces which:</p> <ul style="list-style-type: none"> <li>a) are well designed and constructed;</li> <li>b) durable enough to carry the wheel loads of the intended types and numbers of travelling and parked vehicles;</li> <li>c) ensures the safe passage of vehicles, pedestrians and cyclists, the discharge of stormwater run-off and the preservation of all-weather access;</li> <li>d) allows for reasonable travel comfort.</li> </ul> | <p><b>AO2</b></p> <p>Development provides road pavement surfaces which are designed and constructed in compliance with the road corridor design standards in the Infrastructure design planning scheme policy.</p> | <p><b>AO</b></p> | <p>Any required pavements will be designed in accordance with BCC Standard Drawings and the road corridor design standards in the Infrastructure design planning scheme policy at the detailed design stage.</p>      |             |
| <p><b>PO3</b></p> <p>Development provides a pavement edge which is designed and constructed to:</p> <ul style="list-style-type: none"> <li>a) control vehicle movements by delineating the carriageway for all users;</li> <li>b) provide for people with disabilities by allowing safe passage of wheelchairs and other mobility aids.</li> </ul>   | <p><b>AO3</b></p> <p>Development provides pavement edges which are designed and constructed in compliance with the road corridor design standards in the Infrastructure design planning scheme policy.</p>         | <p><b>AO</b></p> | <p>Any required pavement edges will be designed in accordance with BCC Standard Drawings and the road corridor design standards in the Infrastructure design planning scheme policy at the detailed design stage.</p> |             |
| <p><b>PO4</b></p> <p>Development provides verges which are designed and constructed to:</p> <ul style="list-style-type: none"> <li>a) provide safe access for pedestrians</li> </ul>   | <p><b>AO4</b></p> <p>Development provides verges which are designed and constructed in compliance with the road corridor design and</p>  | <p><b>AO</b></p> | <p>The development will achieve the requirements set out in the road corridor design standards in the infrastructure design planning scheme policy.</p>   |             |

| Performance outcomes   | Acceptable outcomes   | Solutions*        | Comments   | Council Use |
|--|---|-------------------|--|-------------|
| <p>clear of obstructions and access areas for vehicles onto properties;</p> <p>b) provide a sufficient area for public utility services;</p> <p>c) be maintainable by the Council.</p>   | <p>streetscape locality advice standards in the Infrastructure design planning scheme policy.</p>   |                   |  |             |
| <p><b>PO5</b></p> <p>Development provides a lane or laneway identified on the Streetscape hierarchy overlay map or in a neighbourhood plan which:</p> <p>a) allows equitable access for all modes;</p> <p>b) is safe and secure;</p> <p>c) has 24-hour access;</p> <p>d) is a low-speed shared zone environment;</p> <p>e) has a high-quality streetscape.</p> | <p><b>A05</b></p> <p>Development provides a lane or laneway identified on the Streetscape hierarchy overlay map or in a neighbourhood plan which is embellished in compliance with the streetscape locality advice standards in the Infrastructure design planning scheme policy.</p>   | <p><b>N/A</b></p> | <p>No lanes or laneways are proposed as a part of this development.</p>  |             |
| <p><b>PO6</b></p> <p>Development of an existing premises provides at the frontage to the site, if not already provided, the following infrastructure to an appropriate urban standard:</p> <p>a) an effective, high-quality paved roadway;</p> <p>b) an effective, high-quality roadway kerb and channel;</p> <p>c) safe, high-quality vehicle crossings</p>   | <p><b>A06</b></p> <p>Development of an existing premises provides at the frontage of the site, if not already existing, the following infrastructure to the standard that would have applied if the development involved new premises as stated in the road corridor design standards in the Infrastructure design planning scheme policy:</p> <p>a) concrete kerb and channel;</p> | <p><b>AO</b></p>  | <p>Infrastructure at the frontages of the site will be provided in accordance with BCC Standard Drawings and the road corridor design standards in the Infrastructure design planning scheme policy.</p> |             |

| Performance outcomes   | Acceptable outcomes  | Solutions*       | Comments  | Council Use |
|--|--|------------------|---|-------------|
| <p>over channels and verges;</p> <p>d) safe, accessible, high-quality verges compatible and integrated with the surrounding environment;</p> <p>e) safe vehicle access to the site that enables ingress and egress in a forward gear;</p> <p>f) provision of and required alterations to public utilities;</p> <p>g) effective drainage;</p> <p>h) appropriate conduits to facilitate the provision of required street-lighting systems and traffic signals.</p> | <p>b) forming and grading to verges;</p> <p>c) crossings over channels and verges;</p> <p>d) a constructed bikeway;</p> <p>e) a constructed verge or reconstruction of any damaged verge;</p> <p>f) construction of the carriageway;</p> <p>g) payment of costs for required alterations to public utility mains, services or installations;</p> <p>h) construction of and required alterations to public utility mains, services or installations;</p> <p>i) drainage works;</p> <p>j) installation of electrical conduits.</p> |                  |   |             |
| <p><b>PO7</b></p> <p>Development provides both cycle and walking routes which:</p> <p>a) are located, designed and constructed to their network classification (where applicable);</p> <p>b) provide safe and attractive travel routes for pedestrians and cyclists for commuter and recreational</p>  | <p><b>AO7</b></p> <p>Development provides cycle and walking routes which are located, designed and constructed in compliance with the road corridor design and off-road pathway design standards in the Infrastructure design planning scheme policy.</p>  | <p><b>AO</b></p> | <p>Cycle and walking routes will be designed in accordance with BCC Standard Drawings and the road corridor design standards in the Infrastructure design planning scheme policy.</p> |             |

| Performance outcomes   | Acceptable outcomes   | Solutions*       | Comments  | Council Use |
|--|---|------------------|---|-------------|
| <p>purposes;</p> <p>c) provide safe and comfortable access to properties for pedestrians and cyclists;</p> <p>d) incorporate water sensitive urban design into stormwater drainage;</p> <p>e) provide for utilities;</p> <p>f) provide for a high level of aesthetics and amenity, improved liveability and future growth;</p> <p>g) are a low-maintenance asset with a minimal whole-of-life cost;</p> <p>h) minimise the clearing of significant native vegetation.</p> <p>Note—This can be demonstrated in an engineering report prepared and certified by a Registered Professional Engineer Queensland in accordance with the Infrastructure design planning scheme policy.</p> |   |                  |   |             |
| <p><b>PO8</b></p> <p>Development provides refuse and recycling collection, separation and storage facilities that are located and managed so that adverse impacts on building occupants, neighbouring properties and the public realm are minimised.</p>   | <p><b>AO8.1</b></p> <p>Development provides refuse and recycling collection and storage facilities in accordance with the Refuse planning scheme policy.</p> <hr/> <p><b>AO8.2</b></p> <p>Development ensures that refuse and recycling collection and storage location</p> | <p><b>AO</b></p> | <p>The development provides refuse and recycling collection and storage facilities that will not adversely impact on land uses within or adjoining the development in accordance with the Refuse planning scheme policy.</p> <p>Please refer to architectural drawings for further details.</p> |             |

| Performance outcomes   | Acceptable outcomes   | Solutions*       | Comments   | Council Use |
|--|---|------------------|--|-------------|
|  | <p>and design do not have any adverse impact including odour, noise or visual impacts on the amenity of land uses within or adjoining the development.</p> <p>Note—Refer to the Refuse planning scheme policy for further guidance.</p>   |                  |  |             |
| <p><b>PO9</b></p> <p>Development ensures that:</p> <ul style="list-style-type: none"> <li>a) land used for an urban purpose is serviced adequately with regard to water supply and waste disposal;</li> <li>b) the water supply meets the stated standard of service for the intended use and fire-fighting purposes.</li> </ul> | <p><b>AO9.1</b></p> <p>Development ensures that the reticulated water and sewerage distribution system for all services is in place before the first use is commenced.</p> <hr/> <p><b>AO9.2</b></p> <p>Development provides the lot with reticulated water supply and sewerage to a standard acceptable to the distributor–retailer.</p>   | <p><b>AO</b></p> | <p>The development will be provided with reticulated water supply and sewerage connections to QUU’s network prior to use commencing.</p> <p>Please refer to the concept services layout for details on how the site can be serviced by sewer and water infrastructure.</p> |             |
| <p><b>PO10</b></p> <p>Development provides public utilities and street lighting which are the best current or alternative technology and facilitate accessibility, easy maintenance, minimal whole-of-life costs, and minimal adverse environmental impacts.</p>   | <p><b>AO10.1</b></p> <p>Development provides public utilities and street lighting which are located and aligned to:</p> <ul style="list-style-type: none"> <li>a) avoid significant native vegetation and areas identified within the Biodiversity areas overlay map;</li> <li>b) minimise earthworks;</li> <li>c) avoid crossing waterways, waterway corridors and wetlands or if a crossing is unavoidable, tunnel-boring techniques are used to minimise disturbance, and a</li> </ul> | <p><b>AO</b></p> | <p>Public utilities and street lighting location and alignment will be optimised to avoid significant native vegetation, minimise earthworks and avoid crossing waterways in accordance with the standards in the Infrastructure design planning scheme policy.</p>        |             |

| Performance outcomes  | Acceptable outcomes  | Solutions*       | Comments  | Council Use |
|---|--|------------------|---|-------------|
|   | <p>disturbed area is reinstated and restored on completion of the work.</p> <p>Note—Guidance on the restoration of habitat is included in the Biodiversity areas planning scheme policy.</p> <p><b>AO10.2</b></p> <p>Development provides compatible public utility services and street-lighting services which are co-located in common trenching for underground services.</p> <p><b>AO10.3</b></p> <p>Development provides public utilities and street lighting which are designed and constructed in compliance with the public utilities standards in the Infrastructure design planning scheme policy.</p> |                  |   |             |
| <p><b>PO11</b></p> <p>Development ensures that land used for urban purposes is serviced adequately with telecommunications and energy supply.</p> | <p><b>AO11</b></p> <p>Development provides land with the following services to the standards of the approved supplier:</p> <ul style="list-style-type: none"> <li>a) electricity;</li> <li>b) telecommunications services;</li> <li>c) gas service where practicable.</li> </ul>   | <p><b>AO</b></p> | <p>The development can be serviced adequately with gas, telecommunications, and electricity supply.</p>   |             |
| <p><b>PO12</b></p> <p>Development ensures that major public projects promote the provision of affordable, high-bandwidth</p>                      | <p><b>AO12</b></p> <p>Development provides conduits which are provided in all major Council and government works projects to enable the</p>  | <p><b>AO</b></p> | <p>Conduits will be provided where appropriate to enable the future provision of fibre optic cabling.</p> |             |

| Performance outcomes  | Acceptable outcomes   | Solutions*        | Comments  | Council Use |
|---|---|-------------------|---|-------------|
| <p>telecommunications services throughout the city.</p>   | <p>future provision of fibre optic cabling, if:</p> <ul style="list-style-type: none"> <li>a) the additional expense is unlikely to be prohibitive; or</li> <li>b) further major work is unlikely or disruption would be a major concern, such as where there is a limited capacity road; or</li> <li>c) there is a clear gap in the telecommunications network; or</li> <li>d) there is a clear gap in the bandwidth available to the area.</li> </ul> <p>Editor's note—An accurate, digital 'as built' three-dimensional location plan is to be supplied for all infrastructure provided in a road.</p> |                   |   |             |
| <p><b>PO13</b></p> <p>Development provides public art identified in a neighbourhood plan or park concept plan which:</p> <ul style="list-style-type: none"> <li>a) is provided commensurate with the status and scale of the proposed development;</li> <li>b) is sited and designed: <ul style="list-style-type: none"> <li>I. as an integrated part of the project design;</li> <li>II. as conceptually relevant to the context of the location;</li> </ul> </li> </ul> | <p><b>AO13</b></p> <p>Development provides public art identified in a neighbourhood plan or park concept plan which is sited and designed in compliance with the public art standards in the Infrastructure design planning scheme policy.</p>  | <p><b>N/A</b></p> | <p>No public art is proposed as a part of this development.</p> |             |



| Performance outcomes   | Acceptable outcomes   | Solutions* | Comments   | Council Use |
|--|---|------------|--|-------------|
| <p>III. to reflect and respond to the cultural values of the community;</p> <p>IV. to promote local character in a planned and informed manner.</p>                    |   |            |  |             |
| <p><b>PO14</b></p> <p>Development provides signage of buildings and spaces which promote legibility to help users find their way.</p>                                  | <p><b>AO14</b></p> <p>Development provides public signage:</p> <p>a) at public transport interchanges and stops, key destinations, public spaces, pedestrian linkages and at entries to centre developments;</p> <p>b) which details the location of the key destinations, public spaces and pedestrian linkages in the vicinity, the services available within the development and where they are located.</p> | N/A        | Public signage is not required as a part of this development.  |             |
| <p><b>PO15</b></p> <p>Development that provides community facilities which form part of the development is functional, safe, low maintenance, and fit for purpose.</p> | <p><b>AO15</b></p> <p>Development that provides community facilities which form part of the development is designed in compliance with the community facilities standards in the Infrastructure design planning scheme policy.</p>  | AO         | Community facilities will be designed in compliance with the community facilities standards in the Infrastructure design planning scheme policy. |             |
| <p><b>PO16</b></p> <p>Development provides public toilets which:</p> <p>a) are required as part of a community facility or park;</p>                                   | <p><b>AO16</b></p> <p>Development that provides public toilets is designed and constructed in compliance with the public toilets standards in the Infrastructure design planning scheme policy.</p>   | N/A        | No public toilets are proposed as a part of this development.  |             |

| Performance outcomes  | Acceptable outcomes   | Solutions*        | Comments  | Council Use |
|---|---|-------------------|---|-------------|
| <p>b) are located, designed and constructed to be:</p> <ul style="list-style-type: none"> <li>i. safe;</li> <li>ii. durable;</li> <li>iii. resistant to vandalism;</li> <li>iv. able to service expected demand;</li> <li>v. fit for purpose.</li> </ul>  |   |                   |   |             |
| <p><b>PO17</b></p> <p>Development provides bridges, tunnels, elevated structures and water access structures that are designed and constructed using proven methods, materials and technology to provide for:</p> <ul style="list-style-type: none"> <li>a) safe movement of intended users;</li> <li>b) an attractive appearance appropriate to the general surroundings and any adjacent structures;</li> <li>c) functionality and easy maintenance;</li> <li>d) minimal whole-of-life cost;</li> <li>e) longevity;</li> <li>f) current and future services.</li> </ul> <p>Note—All bridges and elevated and associated elements must be designed and certified by a Registered Professional Engineer Queensland in accordance with the Infrastructure design planning scheme policy.</p> | <p><b>AO17</b></p> <p>Development that provides bridges, tunnels, elevated structures and water access structures is designed and constructed in compliance with the standards in the Infrastructure design planning scheme policy.</p> | <p><b>N/A</b></p> | <p>No bridges, tunnels, elevated structures or water access structures are proposed as a part of the development.</p> |             |

| Performance outcomes   | Acceptable outcomes   | Solutions*        | Comments   | Council Use |
|--|---|-------------------|--|-------------|
| <p><b>PO18</b></p> <p>Development provides culverts which are designed and constructed using proven methods, materials and technology to provide for:</p> <ul style="list-style-type: none"> <li>a) safety;</li> <li>b) an attractive appearance appropriate to the general surroundings;</li> <li>c) functionality and easy maintenance;</li> <li>d) minimal whole-of-life cost;</li> <li>e) longevity;</li> <li>f) future widening;</li> <li>g) current and future services;</li> <li>h) minimal adverse impacts, such as increase in water levels or flow velocities, and significant change of flood patterns.</li> </ul> <p>Note—All culverts and associated elements are to be designed and certified by a Registered Professional Engineer Queensland in accordance with the applicable design standards.</p> | <p><b>AO18</b></p> <p>Development that provides culverts is designed and constructed in compliance with the structures standards in the Infrastructure design planning scheme policy.</p> | <p><b>N/A</b></p> | <p>No culverts are proposed as a part of the development.</p>  |             |
| <p><b>PO19</b></p> <p>Development provides batters, retaining walls, and seawalls and river walls which are designed and constructed using proven methods, materials and</p>   | <p><b>AO19</b></p> <p>Development that provides batters, retaining walls, seawalls and river walls is designed and constructed in compliance with the structures standards in the</p>     | <p><b>AO</b></p>  | <p>Batters and retaining walls will be designed and constructed in accordance with the structures standards in the Infrastructure design planning scheme policy.</p> |             |

| Performance outcomes   | Acceptable outcomes  | Solutions* | Comments   | Council Use |
|--|--|------------|--|-------------|
| <p>technology to provide for:</p> <ul style="list-style-type: none"> <li>a) safety;</li> <li>b) an attractive appearance appropriate to the surrounding area;</li> <li>c) easy maintenance;</li> <li>d) minimal whole-of-life cost;</li> <li>e) longevity;</li> <li>f) minimal water seepage.</li> </ul> <p>Note—All retaining walls and associated elements are to be designed and certified by a Registered Professional Engineer Queensland in accordance with the applicable design standards.</p> | <p>Infrastructure design planning scheme policy.</p>   |            |  |             |
| <b>If for development with a gross floor area greater than 1,000m<sup>2</sup></b>  |  |            |  |             |
| <p><b>PO20</b></p> <p>Development ensures that construction is managed so that use of public spaces and movement on pedestrian, cyclist and other traffic routes is not unreasonably disrupted and existing landscaping is adequately protected from short- and long-term impacts.</p> <p>Note—The preparation of a construction management plan can assist in demonstrating achievement of this performance outcome.</p>  | <p><b>AO20</b></p> <p>Development ensures that during construction:</p> <ul style="list-style-type: none"> <li>a) the ongoing use of adjoining and surrounding parks and public spaces, such as malls and outdoor dining, is not compromised;</li> <li>b) adjoining and surrounding landscaping is protected from damage;</li> <li>c) safe, legible, efficient and sufficient pedestrian, cyclist and vehicular accessibility and connectivity to the</li> </ul> | <b>AO</b>  | <p>A construction management plan will be prepared prior to works commencing to ensure that surrounding parks, public spaces and landscaping is protected during construction and that pedestrian, cyclist and vehicular movements can be managed effectively.</p> |             |

| Performance outcomes   | Acceptable outcomes   | Solutions*       | Comments  | Council Use |
|--|---|------------------|---|-------------|
| <p>Note—The Transport, access, parking and servicing planning scheme policy provides advice on the management of vehicle parking and deliveries during construction.</p>   | <p>wider network are maintained.</p>  |                  |   |             |
| <p><b>PO21</b></p> <p>Development ensures that construction and demolition activities are guided by measures that prevent or minimise adverse impacts including sleep disturbance at a sensitive use, due to noise and dust, including dust from construction vehicles entering and leaving the site.</p> <p>Note—A noise and dust impact management plan prepared in accordance with the Management plans planning scheme policy can assist in demonstrating achievement of this performance outcome.</p> | <p><b>AO21.1</b></p> <p>Development ensures that demolition and construction:</p> <p>a) only occur between 6:30am and 6:30pm Monday to Saturday, excluding public holidays;</p> <p>b) do not occur over periods greater than 6 months.</p> <hr/> <p><b>AO21.2</b></p> <p>Development including construction and demolition does not release dust emissions beyond the boundary of the site.</p> <hr/> <p><b>AO21.3</b></p> <p>Development construction and demolition does not involve asbestos-containing materials.</p> | <p><b>AO</b></p> | <p>Demolition and construction works will be limited to the approved working hours.</p> <p>Dust will be managed during construction to ensure it is not blown beyond the property boundary.</p> |             |
| <p><b>PO22</b></p> <p>Development ensures that:</p> <p>a) construction and demolition do not result in damage to surrounding property as a result of vibration;</p> <p>b) vibration levels achieve the vibration criteria in Table 9.4.4.3.B, Table</p>  | <p><b>AO22</b></p> <p>Development ensures that the nature and scale of construction and demolition do not generate noticeable levels of vibration.</p>  | <p><b>AO</b></p> | <p>Vibration levels will be effectively managed during demolition and construction works.</p>   |             |

| Performance outcomes   | Acceptable outcomes  | Solutions*       | Comments   | Council Use |
|--|--|------------------|--|-------------|
| <p>9.4.4.3.C, Table 9.4.4.3.D and Table 9.4.4.3.E.</p> <p>Note—A vibration impact assessment report prepared in accordance with the Noise impact assessment planning scheme policy can assist in demonstrating achievement of this performance outcome.</p>  |  |                  |  |             |
| <p><b>If for a material change of use or reconfiguring a lot in an urban area (as defined in the Regulation) involving premises that is, or will be, accessed by common private title, where involving buildings, either attached or detached, that are not covered by other legislation mandating fire hydrants</b></p> |  |                  |  |             |
| <p><b>PO23</b></p> <p>Development ensures that fire hydrants are:</p> <ul style="list-style-type: none"> <li>a) installed and located to enable fire services to access water safely, effectively and efficiently;</li> <li>b) suitably identified so that fire services can locate them at all hours.</li> </ul>        | <p><b>AO23.1</b></p> <p>Above or below ground fire hydrants are provided on residential, commercial and industrial streets and private roads, at not more than 90m intervals, and at each street intersection.</p> <p>Note—On residential streets, above ground fire hydrants may be single outlet. On commercial and industrial streets above ground fire hydrants should have dual valved outlets.</p> | <p><b>AO</b></p> | <p>Fire hydrants will be provided at no more than 90m spacings and will be identified by marker posts and RRPMS.</p> |             |
|  | <p><b>AO23.2</b></p> <p>Fire hydrants are identified by:</p> <ul style="list-style-type: none"> <li>a) raised reflectorised pavement markers (RRPM) on sealed roads;</li> <li>b) marker posts at the fence line where on an unsealed road, as road (HR) or path (HP) hydrants.</li> </ul>  |                  |  |             |

| Performance outcomes   | Acceptable outcomes  | Solutions*        | Comments  | Council Use |
|--|--|-------------------|---|-------------|
| <p><b>PO24</b></p> <p>Development ensures road widths and construction within the development, are adequate for refuse vehicles and for fire emergency vehicles to gain access to a safe working area close to buildings and near water supplies whether or not on-street parking spaces are occupied.</p> | <p><b>AO24</b></p> <p>Internal private roads have a minimum roadway clearance between obstructions of 3.5m wide and 4.8m high in addition to any width required for on-street parking.</p> | <p><b>AO</b></p>  | <p>Internal private roads have been provided with a minimum roadway clearance of 3.5m wide and 4.8m high for fire emergency vehicles to gain access to a safe working area.</p> |             |
| <p><b>Development for major electricity infrastructure and bulk water supply infrastructure identified on the State Planning Policy Interactive Mapping System where not in the Utility services zone precinct of the Special purpose zone</b></p>   |  |                   |   |             |
| <p><b>PO25</b></p> <p>Development avoids or otherwise minimises adverse impacts on surrounding land uses through the use of buffers and setbacks and the appropriate design and location of plant and operational areas within the site.</p>   | <p><b>AO25</b></p> <p>No acceptable outcome is prescribed.</p>   | <p><b>N/A</b></p> | <p>The development does not involve major electricity infrastructure or bulk water supply infrastructure.</p>   |             |
| <p><b>Development potentially impacting on major electricity infrastructure and bulk water supply infrastructure identified on the State Planning Policy Interactive Mapping System where the infrastructure is not in the Utility services zone precinct of the Special purpose zone</b></p>              |  |                   |   |             |
| <p><b>PO26</b></p> <p>Development is sited and designed to:</p> <ul style="list-style-type: none"> <li>a) avoid safety risks to people or property;</li> <li>b) minimise noise and visual impacts to people and property;</li> </ul>   | <p><b>AO26</b></p> <p>No acceptable outcome is prescribed.</p>   | <p><b>N/A</b></p> | <p>The development is not located near major electricity infrastructure or bulk water supply infrastructure.</p>  |             |

| Performance outcomes  | Acceptable outcomes | Solutions* | Comments | Council Use |
|---|---------------------|------------|----------|-------------|
| c) ensure the physical integrity and operation, maintenance and expansion of the infrastructure is not compromised. |                     |            |          |             |





INERTIA ENGINEERING PTY LTD

2/139 Coronation Drive, MILTON 4064

P | 07 3857 7868 E | [info@inertiaeng.com.au](mailto:info@inertiaeng.com.au)

© Inertia Engineering 2024

This report is and shall remain the property of Inertia Engineering Pty Ltd. The document may only be used for the purpose for which it was commissioned and in accordance with the Terms of Engagement for the commission. Unauthorised use of this document in any form whatsoever is prohibited.